

WCAB

Cold Applied Insulation Boot



Description

Wear elastomeric insulating boots are molded parts which fit over the connection between the cable lug and the inline or right-angled bushing to improve phase-to-phase and phase-to-ground insulation. They are used in switchgears and transformers where the clearances are insufficient for normal operation, or to protect against flashover rodents or high humidity.

Features

- Made of silicone rubber.
- Collar is optional for use where the bushing size is smaller.
- Offering tailor-made solutions against specific requirements (size, color).
- Connection can be energized immediately after installation.
- Excellent tracking and erosion resistance.
- Removable and re-installable.
- Fast and simple installation.
- Unlimited shelf life.

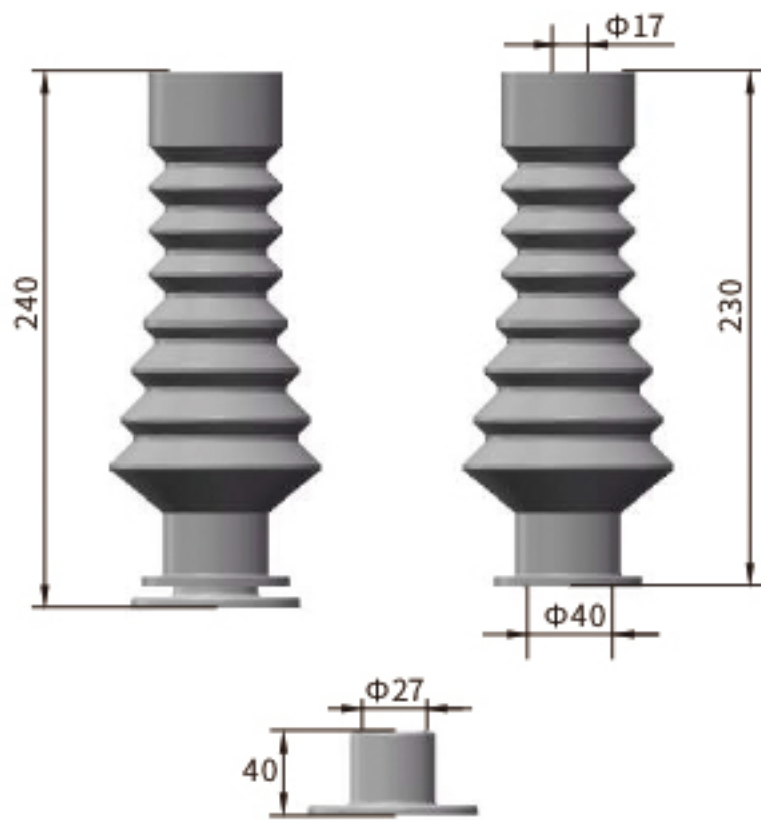

Technical Data

Maximum System Voltage	17.5kV
Basic Impulse Level	95kV
Collar Size	27mm
Bushing Diameter	31-45mm
Bushing Types	250A/630A
Cable Cross Section	35-400mm ²

RST

Heat Shrink Termination for LV Cables



Termination kit for 4-core cables

The terminations are designed for 1-, 2-, 3-, 4- and 5-core cables with or without armour. The terminations are also applicable to 3+1, 4+1 and 3+2 cables.

The cable crutch is sealed by a breakout inner coated with adhesive. Heat shrink insulation tubes seal between the cable lug and the bottom of the core insulation. For single core cables only an insulation tube is needed. All materials are resistant to UV and weathering.

Selection Table

Voltage	Cores	Cross Section/mm ²	Kit No.
0.6/1(1.2)kV	1,2,3,4,5	4-6	0.6/1kVRST-4(5,3,2)/(-1)
		10-16	0.6/1kVRST-4(5,3,2)/0
		25-50	0.6/1kVRST-4(5,3,2,1)/1
		70-120	0.6/1kVRST-4(5,3,2,1)/2
		150-240	0.6/1kVRST-4(5,3,2,1)/3
		300-400	0.6/1kVRST-4(5,3,2,1)/4
		500	0.6/1kVRST-4(3,2,1)/5

Note:

Solderless earth connection system for armoured cables is available on request.

Lugs and other accessories shall be ordered separately.

Terminations and components for other cable types are available on request.

RSNY/RSWY

Heat Shrink Termination For MV Cables Up To 42kV

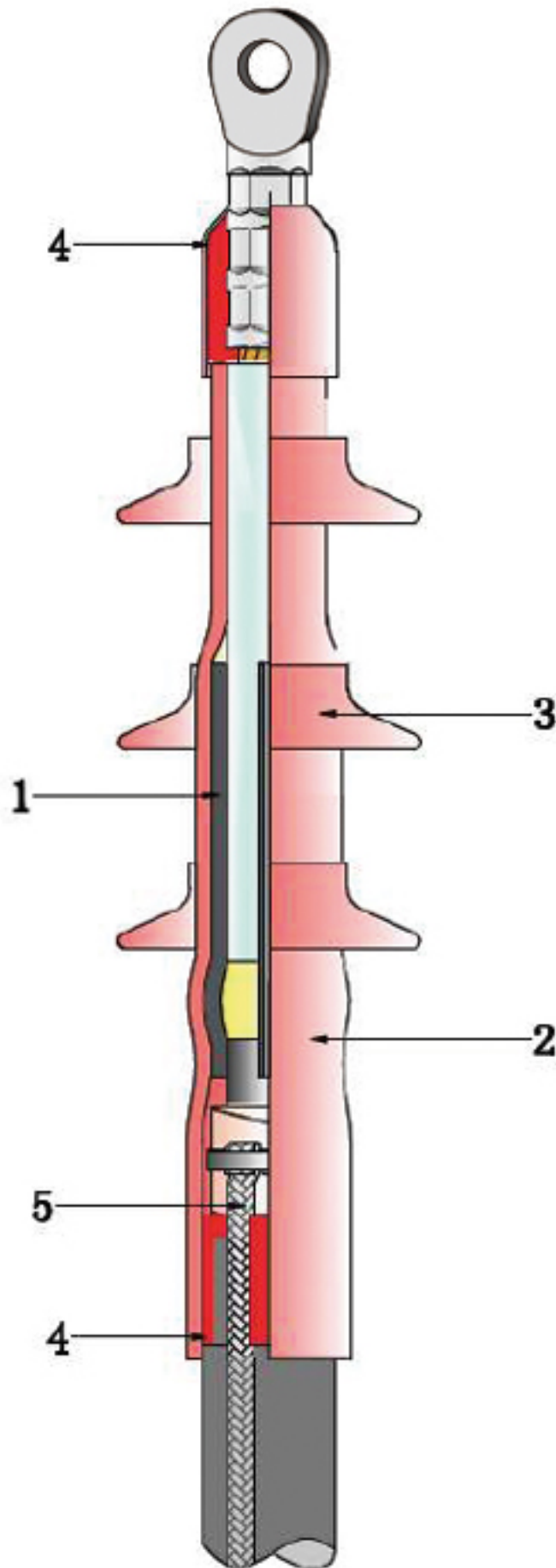

Design of Termination

Woer provides a universal system for indoor and outdoor terminations applicable to paper or polymeric insulated cables.

1. Electrical Stress Control

Yellow stress relief mastic is laid around the end of the screen cut. Stress control tube, together with stress relief mastic, is used to smooth out the electrical field at the cable end.

2. Excellent Anti-tracking Properties

Anti-tracking insulation tubes and rain sheds demonstrate excellent tracking and erosion resistance. This protect Woer terminations from tracking even in severe service conditions.

3. Additional Creepage

Anti-tracking rain sheds lengthen surface creepage distance.

4. Moisture Sealing

Durable sealing is achieved by hot-melted adhesive inside the sealing tube and anti-tracking insulation tube. For 3-core cables, the crutch area is sealed and protected with an adhesive-coated breakout which is installed over the cores and the end of overshath.

5. Earth Connection

Either soldering or solderless earth connection is available to connect metal screen or armour to ground. For cables with wire screen, copper wires are imbedded in the sealing mastic to prevent any corrosion and moisture sealing.



RSNY-1

Indoor termination for screened, 1-core polymeric insulated cables 6kV, 10kV, 20kV, 30kV and 35kV

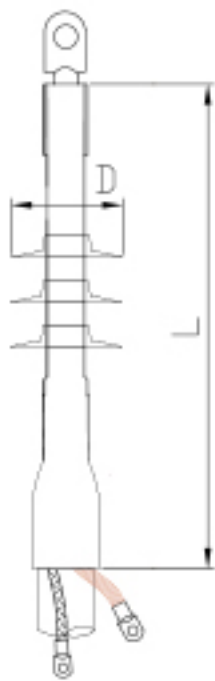

The indoor termination is designed for screened single core polymeric insulated MV cables up to 35kV.

Yellow stress relief mastic is laid around the end of the screen cut. Stress control tube, together with stress relief mastic, is used to smooth out the electrical field at the cable screen end. Anti-tracking insulation tube and sealing tube seal between the end of the oversheath and the cable lug. Anti-tracking rain sheds lengthen surface creepage distance to ensure safety.

Nominal voltage U_o/U_n	Cross section (mm ²)	Kit No.	Dimensions (mm)		No. of rain sheds
			L	D	
3.6 / 6(7.2)kV	50-120 150-240 300-400 500	6kVRSNY-1/1 6kVRSNY-1/2 6kVRSNY-1/3 6kVRSNY-1/4	800	-	0
6 / 10(12)kV 6.35 / 11(12)kV	50-95 120-185 240-300 400-500 630	10kVRSNY-1/1 10kVRSNY-1/2 10kVRSNY-1/3 10kVRSNY-1/4 10kVRSNY-1/5	800	-	0
8.7 / 15(17.5)kV	25-50 70-120 150-240 300-400 500-630	10kVRSNY-1/1 10kVRSNY-1/2 10kVRSNY-1/3 10kVRSNY-1/4 10kVRSNY-1/5	800	-	0
12 / 20(24)kV 12.7 / 22(24)kV	35-50 70-120 150-240 300-400 500-630 800-1000 1200	20kVRSNY-1/1 20kVRSNY-1/2 20kVRSNY-1/3 20kVRSNY-1/4 20kVRSNY-1/5 20kVRSNY-1/6 20kVRSNY-1/7	800	105 105 105 140 140 140 140	2
18 / 30(36)kV 19 / 33(36)kV	35-50 70-120 150-240 300-400 500-630 800-1000 1200	30kVRSNY-1/1 30kVRSNY-1/2 30kVRSNY-1/3 30kVRSNY-1/4 30kVRSNY-1/5 30kVRSNY-1/6 30kVRSNY-1/7	800	105 105 140 140 140 140 140	4
20.8 / 36(42)kV 26 / 35(42)kV	50 70-120 150-240 300-400 500-630 800-1000 1200	35kVRSNY-1/1 35kVRSNY-1/2 35kVRSNY-1/3 35kVRSNY-1/4 35kVRSNY-1/5 35kVRSNY-1/6 35kVRSNY-1/7	800	140 140 140 140 140 140 140	4

Note:

1. Lugs need to be ordered separately.
2. RSNY-1 is for cables with copper wire screen without armour.
3. For cables with other construction, please order kits separately.

Remark: Above cross-section range selection is for reference, the final determination factor is the diameter over insulation.

RSWY-1

Outdoor termination for screened, 1-core polymeric insulated cables 6kV, 10kV, 20kV, 30kV and 35kV

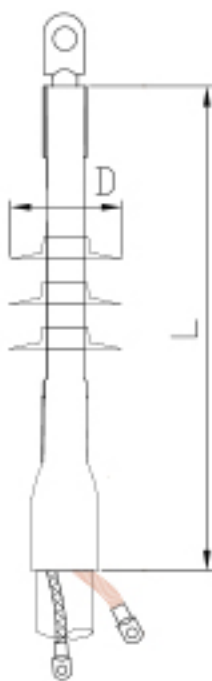

The outdoor termination is designed for screened single core polymeric insulated MV cables up to 35kV.

Yellow stress relief mastic is laid around the end of the screen cut. Stress control tube, together with stress relief mastic, is used to smooth out the electrical field at the cable screen end. Anti-tracking insulation tube and sealing tube seal between the end of the oversheath and the cable lug. Anti-tracking rain sheds lengthen surface creepage distance to ensure safety.

Nominal voltage $U_0/U(U_n)$	Cross section (mm ²)	Kit No.	Dimensions (mm)		No. of rain sheds
			L	D	
3.6 / 6(7.2)kV	50-120	6kVRSWY-1/1	800	105	3
	150-240	6kVRSWY-1/2		105	
	300-400	6kVRSWY-1/3		105	
	500	6kVRSWY-1/4		140	
6 / 10(12)kV 6.35 / 11(12)kV	50-95	10kVRSWY-1/1	800	105	3
	120-185	10kVRSWY-1/2		105	
	240-300	10kVRSWY-1/3		105	
	400-500	10kVRSWY-1/4		140	
	630	10kVRSWY-1/5		140	
8.7 / 15(17.5)kV	25-50	10kVRSWY-1/1	800	105	3
	70-120	10kVRSWY-1/2		105	
	150-240	10kVRSWY-1/3		105	
	300-400	10kVRSWY-1/4		140	
	500-630	10kVRSWY-1/5		140	
12 / 20(24)kV 12.7 / 22(24)kV	35-50	20kVRSWY-1/1	800	105	4
	70-120	20kVRSWY-1/2		105	
	150-240	20kVRSWY-1/3		105	
	300-400	20kVRSWY-1/4		140	
	500-630	20kVRSWY-1/5		140	
	800-1000	20kVRSWY-1/6		140	
	1200	20kVRSWY-1/7		140	
18 / 30(36)kV 19 / 33(36)kV	35-50	30kVRSWY-1/1	800	105	6
	70-120	30kVRSWY-1/2		105	
	150-240	30kVRSWY-1/3		140	
	300-400	30kVRSWY-1/4		140	
	500-630	30kVRSWY-1/5		140	
	800-1000	30kVRSWY-1/6		140	
	1200	30kVRSWY-1/7		140	
20.8 / 36(42)kV 26 / 35(42)kV	50	35kVRSWY-1/1	800	140	6
	70-120	35kVRSWY-1/2		140	
	150-240	35kVRSWY-1/3		140	
	300-400	35kVRSWY-1/4		140	
	500-630	35kVRSWY-1/5		140	
	800-1000	35kVRSWY-1/6		140	
	1200	35kVRSWY-1/7		140	

Note:

1. Lugs need to be ordered separately.
2. RSWY-1 is for cables with copper wire screen without armour.
3. For cables with other construction, please order kits separately.

Remark: Above cross-section range selection is for reference, the final determination factor is the diameter over insulation.

RSNY-3

Indoor termination for screened, 3-core polymeric insulated cables 6kV, 10kV, 20kV, 30kV and 35kV



The indoor termination is designed for screened three core polymeric insulated MV cables up to 35kV.

Yellow stress relief mastic is laid around the end of the screen cut. Stress control tube, together with stress relief mastic, is used to smooth out the electrical field at the cable screen end. All phase cores are covered with anti-tracking insulation tube and sealing tube. Anti-tracking rain sheds lengthen surface creepage distance to ensure safety. The crutch area is sealed and protected with an adhesive-coated breakout which is installed over the cores at the end of overshooth.

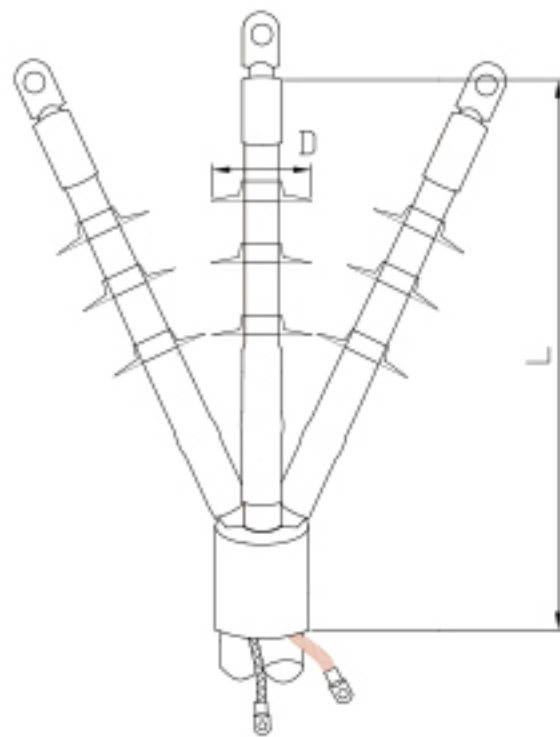

Nominal voltage $U_o/U(U_n)$	Cross section (mm ²)	Kit No.	Dimensions (mm)		No. of rain sheds
			L	D	
3.6 / 6(7.2)kV	50-120	6kVRSNY-3/1	750	-	0
	150-240	6kVRSNY-3/2			
	300-400	6kVRSNY-3/3			
	500	6kVRSNY-3/4			
6 / 10(12)kV 6.35 / 11(12)kV	50-95	10kVRSNY-3/1	750	-	0
	120-185	10kVRSNY-3/2			
	240-300	10kVRSNY-3/3			
	400-500	10kVRSNY-3/4			
	630	10kVRSNY-3/5			
8.7 / 15(17.5)kV	25-50	10kVRSNY-3/1	750	-	0
	70-120	10kVRSNY-3/2			
	150-240	10kVRSNY-3/3			
	300-400	10kVRSNY-3/4			
	500-630	10kVRSNY-3/5			
12 / 20(24)kV 12.7 / 22(24)kV	35-50	20kVRSNY-3/1	900	105	6
	70-120	20kVRSNY-3/2		105	
	150-240	20kVRSNY-3/3		105	
	300-400	20kVRSNY-3/4		140	
	500-630	20kVRSNY-3/5		140	
18 / 30(36)kV 19 / 33(36)kV	35-50	30kVRSNY-3/1	1100	105	12
	70-120	30kVRSNY-3/2		105	
	150-240	30kVRSNY-3/3		140	
	300-400	30kVRSNY-3/4		140	
	500-630	30kVRSNY-3/5		140	
20.8 / 36(42)kV 26 / 35(42)kV	50	35kVRSNY-3/1	1100	140	12
	70-120	35kVRSNY-3/2		140	
	150-240	35kVRSNY-3/3		140	
	300-400	35kVRSNY-3/4		140	
	500-630	35kVRSNY-3/5		140	

Note:

1. Lugs need to be ordered separately.
2. RSNY-3 is for cables with copper wire screen without armour.
3. For cables with other construction, please order kits separately.

Remark: Above cross-section range selection is for reference, the final determination factor is the diameter over insulation.

RSJ

Heat Shrink Joints for LV Cables



Joint Kit for LV 4-core Cable

The joints are designed for 1-, 2-, 3-, 4- and 5-core cables with or without armour. The joints are also applicable to 3+1, 4+1 and 3+2 cables.

The connectors are insulated and sealed with adhesive coated insulation tubes. The outer tube provides mechanical protection and chemical resistance as expected from cable oversheath. All joints are designed to allow crossing of cable cores.

Selection Table

Voltag e $U_o/U(U_n)$	Cores	Cross Section/ mm^2	Kit No.
0.6/1(1.2)kV	4, 5, 3, 2, 1	4-6	0.6/1kVRSJ-4(5,3,2)/(-1)
		10-16	0.6/1kVRSJ-4(5,3,2)/0
		25-50	0.6/1kVRSJ-4(5,3,2,1)/1
		70-120	0.6/1kVRSJ-4(5,3,2,1)/2
		150-240	0.6/1kVRSJ-4(5,3,2,1)/3
		300-400	0.6/1kVRSJ-4(5,3,2,1)/4
		500	0.6/1kVRSJ-4(3,1)/5

Note:

1. Joints and components for other cable types are available on request.
2. Solderless earth connection system for armoured cables is available on request.
3. Connectors and other accessories need to be ordered separately.

RSJY

Heat Shrink Joints For MV Cables Up To 42kV

Design of Joint

The joints are designed for MV screened, 1-core polymeric insulated cables with or without armour. The same design principles are used for 3-core cables.

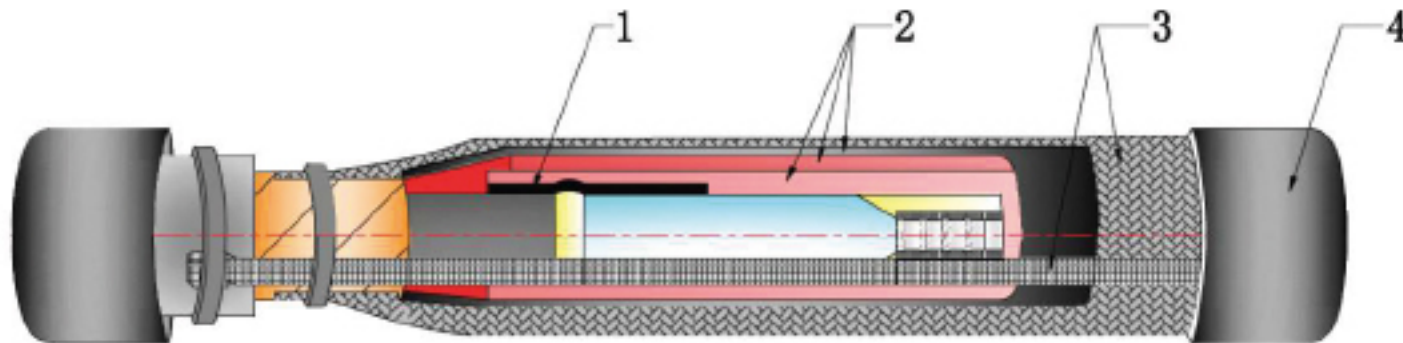

1. Electrical stress control

Stress control tube, together with stress relief mastic, is used to smooth out the electrical field at the cable screen ends.

2. Insulation and screen

Heat shrink insulation tube delivers consistent insulation thickness to meet or exceed that of the cable.

Heat shrink semi-conductive /insulation dual layer tube is also adopted to help ensure a void-free interface between the insulation and screen.

3. Metallic shielding

Copper mesh wrapped around the joint area rebuilds the metallic screen. Either soldering or solderless earth connection is available to provide screen continuity across the joint.

4. Outer sealing and protection

The outer sealing and protection is performed by an adhesive coated heat shrink tube. It provides mechanical protection and chemical resistance as expected from cable overheath.



RSJY-1

Straight joint for screened, 1-core polymeric insulated cables 6kV, 10kV, 20kV, 30kV and 35kV

The joint is designed for screened single core polymeric insulated MV cables up to 35kV.

Stress control tube, together with stress relief mastic, is used to smooth out the electrical field at the cable screen ends. Heat shrink insulation tube delivers consistent insulation thickness over the core insulation. Heat shrink dual layer tube is adopted to help ensure a void-free interface between the insulation and screen. Copper mesh wrapped around the joint area rebuilds the metallic screen. Either soldering or solderless earth connection is available to provide screen continuity across the joint. The outer sealing and protection is performed by an adhesive coated heat shrink tube.

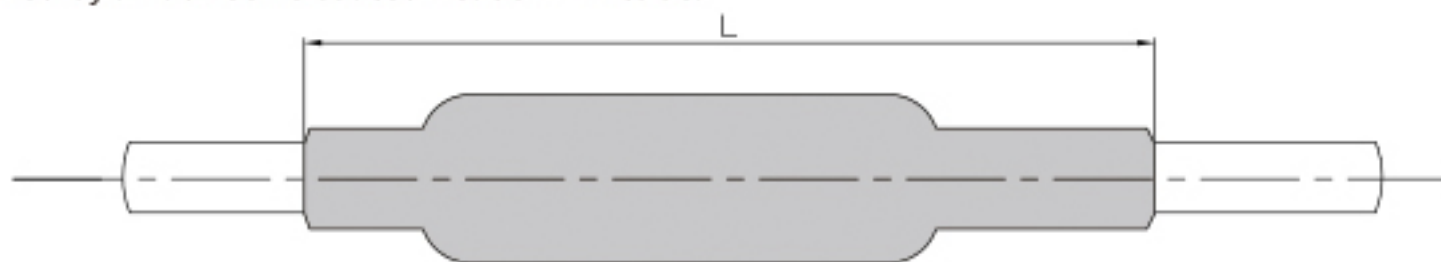

Selection Table

Nominal voltage $U_0/U(U_{sc})$	Cross section (mm ²)	Kit No.	L Dimensions(mm)
3.6 / 6(7.2)kV	50-120	6kVRSJY-1/1	1000
	150-240	6kVRSJY-1/2	1000
	300-400	6kVRSJY-1/3	1000
	500	6kVRSJY-1/4	1000
6 / 10(12)kV 6.35 / 11(12)kV	50-95	10kVRSJY-1/1	1000
	120-185	10kVRSJY-1/2	1000
	240-300	10kVRSJY-1/3	1000
	400-500	10kVRSJY-1/4	1000
	630	10kVRSJY-1/5	1000
8.7 / 15(17.5)kV	25-50	10kVRSJY-1/1	1000
	70-120	10kVRSJY-1/2	1000
	150-240	10kVRSJY-1/3	1000
	300-400	10kVRSJY-1/4	1000
	500-630	10kVRSJY-1/5	1000
12 / 20(24)kV 12.7 / 22(24)kV	35-50	20kVRSJY-1/1	1000
	70-120	20kVRSJY-1/2	1000
	150-240	20kVRSJY-1/3	1000
	300-400	20kVRSJY-1/4	1200
	500-630	20kVRSJY-1/5	1200
	800-1000	20kVRSJY-1/6	1200
	1200	20kVRSJY-1/7	1200
18 / 30(36)kV 19 / 33(36)kV	35-50	30kVRSJY-1/1	1400
	70-120	30kVRSJY-1/2	1400
	150-240	30kVRSJY-1/3	1400
	300-400	30kVRSJY-1/4	1400
	500-630	30kVRSJY-1/5	1400
	800-1000	30kVRSJY-1/6	1400
	1200	30kVRSJY-1/7	1400
20.8 / 36(42)kV 26 / 35(42)kV	50	35kVRSJY-1/1	1400
	70-120	35kVRSJY-1/2	1400
	150-240	35kVRSJY-1/3	1400
	300-400	35kVRSJY-1/4	1500
	500-630	35kVRSJY-1/5	1500
	800-1000	35kVRSJY-1/6	1500
	1200	35kVRSJY-1/7	1500

Note:

- 1.Connectors need to be ordered separately.
- 2.RSJY-1 is for cables with copper wire screen without armour.
- 3.For cables with other construction, please order kits separately.

Remark: Above cross-section range selection is for reference, the final determination factor is the diameter over insulation

RSJY-3

Straight joint for screened, 3-core polymeric insulated cables 6kV, 10kV, 20kV, 30kV and 35kV

The joint is designed for screened three core polymeric insulated MV cables up to 35kV.

Stress control tube, together with stress relief mastic, is used to smooth out the electrical field at the cable screen ends. Heat shrink insulation tube delivers consistent insulation thickness over the core insulation. Heat shrink dual layer tube is adopted to help ensure a void-free interface between the insulation and screen. Copper mesh wrapped around the joint area rebuilds the metallic screen. Either soldering or solderless earth connection is available to provide screen continuity across the joint. The outer sealing and protection is performed by an adhesive coated heat shrink tube.

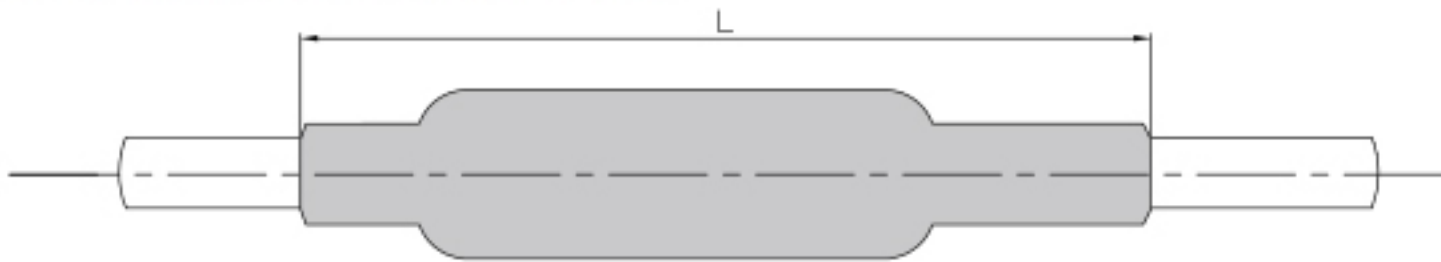

Selection Table

Nominal voltage $U_0/U(U_m)$	Cross section (mm ²)	Kit No.	L Dimensions(mm)
3.6 / 6(7.2)kV	50-120	6kVRSJY-3/1	1800
	150-240	6kVRSJY-3/2	1800
	300-400	6kVRSJY-3/3	1800
	500	6kVRSJY-3/4	1800
6 / 10(12)kV 6.35 / 11(12)kV	50-95	10kVRSJY-3/1	1800
	120-185	10kVRSJY-3/2	1800
	240-300	10kVRSJY-3/3	1800
	400-500	10kVRSJY-3/4	1800
	630	10kVRSJY-3/5	1800
8.7 / 15(17.5)kV	25-50	10kVRSJY-3/1	1800
	70-120	10kVRSJY-3/2	1800
	150-240	10kVRSJY-3/3	1800
	300-400	10kVRSJY-3/4	1800
	500-630	10kVRSJY-3/5	1800
12 / 20(24)kV 12.7 / 22(24)kV	35-50	20kVRSJY-3/1	1800
	70-120	20kVRSJY-3/2	1800
	150-240	20kVRSJY-3/3	1800
	300-400	20kVRSJY-3/4	2600
	500-630	20kVRSJY-3/5	2600
18 / 30(36)kV 19 / 33(36)kV	35-50	30kVRSJY-3/1	2700
	70-120	30kVRSJY-3/2	2700
	150-240	30kVRSJY-3/3	2700
	300-400	30kVRSJY-3/4	2700
	500-630	30kVRSJY-3/5	2700
20.8 / 36(42)kV 26 / 35(42)kV	50	35kVRSJY-3/1	2700
	70-120	35kVRSJY-3/2	2700
	150-240	35kVRSJY-3/3	2700
	300-400	35kVRSJY-3/4	2800
	500-630	35kVRSJY-3/5	2800

Note:

- 1.Connectors need to be ordered separately.
- 2.RSJY-3 is for cables with copper wire screen without armour.
- 3.For cables with other construction, please order kits separately.

Remark: Above cross-section range selection is for reference, the final determination factor is the diameter over insulation

WRSJG

Heat Shrink Anti-tracking Insulation Tube



- Manufactured from cross linked polyolefin, inner coated with adhesive at one end.
- Protecting against accidental flashover.
- Used in medium voltage cable terminations up to 42 kV.
- Shrink temperature: start at 90°C, and fully recovered at 130°C.
- Color: red.

Selection Table

Spec.	As Supplied/mm		After Recovered/mm		Standard Cut Length /mm	Standard Continuous Length (m/roll)
	Inner Diameter Min	Wall Thickness (±0.3)	Inner Diameter Max	Wall Thickness (±0.3)		
WRSJG-30/12	30	1.0	12	2.2	600-1200	25
WRSJG-35/14	35	1.0	14	2.3	600-1200	25
WRSJG-40/17	40	1.0	17	2.3	600-1200	25
WRSJG-50/22	50	1.0	22	2.5	600-1200	25
WRSJG-35/13	35	1.2	13	3.0	600-1200	25
WRSJG-40/15	40	1.2	15	3.0	600-1200	25
WRSJG-50/19	50	1.1	19	3.0	600-1200	25
WRSJG-55/24	55	1.4	24	3.2	600-1200	15
WRSJG-60/26	60	1.4	26	3.2	600-1200	15
WRSJG-70/29	70	1.4	29	3.2	600-1200	15
WRSJG-75/35	75	1.5	35	3.2	600-1200	15
WRSJG-80/36	80	1.4	36	3.2	600-1200	15
WRSJG-90/41	90	1.6	41	3.5	600-1200	15
WRSJG-100/45	100	1.5	45	3.5	600-1200	15

WRSHG

Heat Shrink Protective Tube

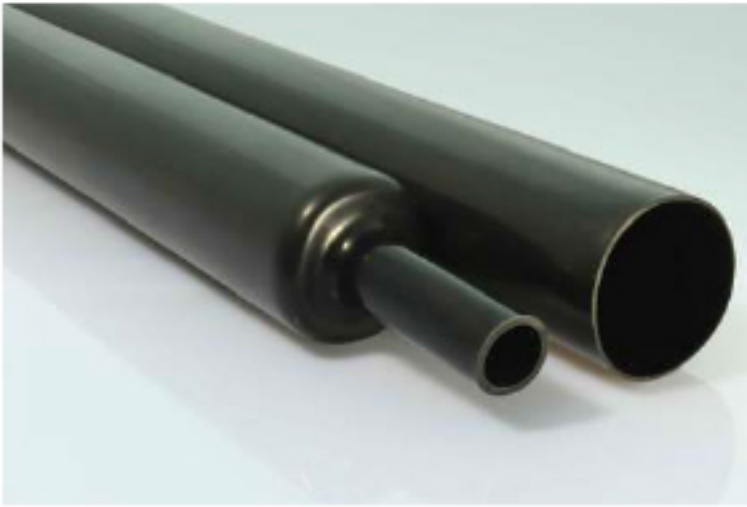

- Manufactured from cross linked polyolefin.
- Providing outer sealing protection for power cable joints up to 42kV.
- Used in 1kV cable joints and terminations to provide electrical insulation ($\Phi 50$ and below).
- Outstanding abrasion and chemical resistance.
- Inner coated with adhesive at both ends. Tubes inner coated with adhesive at full length are available upon customer request.
- Shrink temperature: start at 90°C, and fully recovered at 130°C
Color: black, red, yellow, blue, green($\Phi 50$ and below); black only(above $\Phi 50$). Other colors are available upon customer request.

Selection Table

Spec.	As Supplied/mm		After Recovered/mm		Standard Cut Length/mm	Standard Continuous Length (m/roll)
	Inner Diameter Min	Wall Thickness (± 0.2)	Inner Diameter Max	Wall Thickness (± 0.3)		
WRSHG-10/5	10	0.5	5	1.1	275-1000	25
WRSHG-15/7	15	0.5	7	1.1	275-1000	25
WRSHG-20/9	20	0.6	9	1.5	275-1000	25
WRSHG-30/11	30	0.7	11	1.6	275-1000	25
WRSHG-35/13	35	0.7	13	1.8	275-1000	25
WRSHG-45/17	45	0.8	17	2.0	275-1000	25
WRSHG-50/23	50	1.1	23	2.5	800-1200	25
WRSHG-60/23	60	1.0	23	2.5	800-1200	25
WRSHG-85/30	85	1.0	30	2.8	800-1200	25
WRSHG-100/39	100	1.1	39	3.0	800-1200	15
WRSHG-120/45	120	1.1	45	3.0	800-1200	15
WRSHG-140/49	140	1.2	49	3.6	800-1200	15
WRSHG-160/57	160	1.2	57	3.6	800-1200	/
WRSHG-180/61	180	1.3	61	4.0	800-1200	/
WRSHG-200/70	200	1.5	70	4.4	800-1200	/
WRSHG-230/72	220	1.4	72	4.4	800-1200	/
WRSHG-250/87	250	1.6	87	4.4	800-1200	/
WRSHG-300/100	290	1.4	100	4.4	800-1200	/

WRSYL

Heat Shrink Stress Control Tube



- Manufactured from cross linked polyolefin.
- Providing effective electrical stress control for MV cable terminations and joints up to 42 kV.
- Continuous operation temperature: -40°C to 100°C.
- Shrink temperature: start at 90°C, and fully recovered at 130°C.
- Color: black.

Selection Table

Spec.	As Supplied/mm		After Recovered/mm		Standard Cut Length /mm	Standard Continuous Length (m/roll)
	Inner Diameter Min	Wall Thickness (±0.3)	Inner Diameter Max	Wall Thickness (±0.3)		
WRSYL-30/11	30	0.8	11	2.0	100-1200	25
WRSYL-35/14	35	0.8	14	2.0	100-1200	25
WRSYL-40/17	40	0.8	17	2.0	100-1200	25
WRSYL-45/20	45	0.8	20	2.0	100-1200	25
WRSYL-50/22	50	1.2	22	2.6	100-1200	25
WRSYL-55/24	55	1.4	24	3.3	100-1200	15
WRSYL-60/29	60	1.3	29	3.3	100-1200	15
WRSYL-70/29	70	1.3	29	3.3	100-1200	15
WRSYL-80/29	80	1.2	29	3.3	100-1200	15
WRSYL-95/42	95	1.4	42	3.6	100-1200	15
WRSYL-100/43	100	1.3	43	3.6	100-1200	15
WRSYL-120/45	120	1.1	45	3.6	100-1200	15

Technical Data

Property	Test Method	Standard
Tensile Strength	ASTM-D-638	≥ 10MPa
Elongation at Break	ASTM-D-638	≥ 350%
Tensile Strength Variation After Heat Aging (130°Cx168h)	ASTM-D-5510	≤ ±20%
Elongation at Break Variation After Heat Aging (130°Cx168h)	ASTM-D-5510	≤ ±20%
Volume Resistivity	IEC 60093	≥ 1x10 ¹⁰ Ω.cm
Dielectric Constant	IEC 60250	≥ 15
Hardness (Shore A)	ISO 868	≥ 80
Longitudinal Shrinkage	ASTM-D-2671	≤ 5%
Eccentricity	ASTM-D-2671	≤ 30%

WRSBG

Heat Shrink Semi-conductive Tube



- Manufactured from cross linked semi-conductive polyolefin.
- Shrink temperature: start at 90°C, and fully recovered at 130°C.
- Color: black.

Selection Table

Spec.	As Supplied/mm		After Recovered/mm		Standard Cut Length/mm	Standard Continuous Length (m/roll)
	Inner Diameter Min	Wall Thickness (± 0.3)	Inner Diameter Max	Wall Thickness (± 0.3)		
WRSBG-45/17	45	0.9	17	2.3	400-1200	25
WRSBG-50/20	50	0.9	20	2.3	400-1200	25
WRSBG-55/23	55	0.9	23	2.3	400-1200	25
WRSBG-60/24	60	0.9	24	2.3	400-1200	25
WRSBG-65/25	65	0.8	25	2.3	400-1200	25
WRSBG-75/29	75	1.0	29	2.7	400-1200	25
WRSBG-90/30	90	0.8	30	2.7	400-1200	25
WRSBG-100/36	100	0.9	36	2.7	400-1200	15
WRSBG-120/37	120	0.8	37	2.7	400-1200	15
WRSBG-150/55	150	0.8	55	3.4	400-1200	15

Technical Data

Property	Test Method	Standard Value
Tensile Strength	ASTM-D-638	$\geq 10\text{MPa}$
Elongation at Break	ASTM-D-638	$\geq 350\%$
Tensile Strength Variation After Heat Aging (130°Cx168h)	ASTM-D-5510	$\leq \pm 20\%$
Elongation at Break Variation After Heat Aging (130°Cx168h)	ASTM-D-5510	$\leq \pm 20\%$
Volume Resistivity	IEC 60093	$\geq 1 \times 10^9 \Omega \cdot \text{cm}$
Hardness (Shore A)	ISO 868	≥ 80
Heat Shock	160°C, 4h	No Crack
Brittle Temperature	ISO 974	-40°C
Longitudinal Shrinkage	ASTM-D-2671	$\leq 10\%$
Eccentricity	ASTM-D-2671	$\leq 30\%$

WRSGY

Heat Shrink Oil-resistant Tube



- Manufactured from cross-linked polyolefin.
- Mainly used in PILC cable terminations and joints, offering oil resistance, insulation and sealing protection.

Selection Table

Spec.	As Supplied/mm		After Recovered/mm		Standard Length /mm
	Inner Diameter Min	Wall Thickness (± 0.3)	Inner Diameter Max	Wall Thickness (± 0.3)	
WRSGY-20/8	20	0.7	8	1.8	300-1000
WRSGY-30/11	30	0.7	11	1.8	300-1000
WRSGY-35/12	35	0.7	12	2.0	300-1000
WRSGY-40/17	40	1.0	17	2.2	300-1000
WRSGY-50/22	50	1.7	22	3.7	300-1000
WRSGY-60/23	60	1.4	23	3.7	300-1000
WRSGY-75/29	75	1.1	29	2.8	300-1000
WRSGY-85/30	85	0.9	30	2.8	300-1000
WRSGY-100/38	100	1.1	38	3.0	300-1000
WRSGY-120/45	120	1.1	45	3.0	300-1000

Technical Data

Property	Test Method	Standard Value
Tensile Strength	ASTM-D-638	$\geq 10\text{MPa}$
Elongation at Break	ASTM-D-638	$\geq 350\%$
Tensile Strength Variation After Heat Aging (130°Cx168h)	ASTM-D-5510	$\leq \pm 20\%$
Elongation at Break Variation After Heat Aging (130°Cx168h)	ASTM-D-5510	$\leq \pm 20\%$
Tensile Strength Variation After Oil Resistance (80°C Cable Oil, 168hrs)	ASTM-D-538	$\leq \pm 20\%$
Elongation at Break Variation After Oil Resistance (80°C Cable Oil, 168hrs)	ASTM-D-538	$\leq \pm 20\%$
Volume Resistivity	IEC 60093	$\geq 1 \times 10^{14} \Omega \cdot \text{cm}$
Dielectric Strength	IEC 60243	$\geq 20\text{kV/mm}$
Dielectric Constant	IEC 60250	≤ 4
Hardness (Shore A)	ISO 868	≥ 80
Heat Shock	160°C, 4h	No Crack

WRSGG Heat Shrink Silicone Rubber Tube



- Made of silicone rubber.
- Used for insulation, protection, and sheathing applications.
- Superior heat and cold resistance, flexibility, and electrical insulation.
- Standard color: Black and grey.
- Other colors are available upon request.

Selection Table

Spec.	As Supplied/mm		After Recovered/mm	
	Inner Diameter Min	Wall Thickness (± 0.3)	Inner Diameter Max	Wall Thickness (± 0.3)
WRSGG-6	6	0.55	3.6	1.0

Technical Data

Property	Test Method	Standard Value
Tensile Strength	ASTM-D-638	≥ 4.5 MPa
Elongation at Break	ASTM-D-638	$\geq 450\%$
Tear Strength	ISO 34	≥ 20 kN/m
Dielectric Strength	IEC60243	≥ 20 kV/mm
Volume Resistivity	IEC60093	$\geq 1 \times 10^{12}$ $\Omega \cdot \text{cm}$

WRS LD

Heat Shrink Neoprene Tube



- Made of cross linked chlorinated polyolefin.
- Resistant to most fluids and solvents, including aviation and ground-vehicle fuels, lubricating oil, and hydraulic fluids.
- Good flexibility at low temperature.
- Resistant to abrasion and physical abuse while providing flexibility and strain relief.
- Performance meets requirements of SAE-AMS-DTL-23053/1.
- Widely used for insulation, strain relief, and abrasion protection on cable harnesses and wire bundles in the military and aerospace.
- Especially suitable for applications requiring exposure to fluids and solvents at elevated temperatures.
- RoHS compliant.
- Shrink temperature: start at 90°C, and fully recovered at 130°C.
- Standard color: black.

Technical Data

Property	Test Method	Standard Value
Tensile Strength	ASTM D 412	≥10.3MPa
Elongation at Break	ASTM D 412	≥225%
Tensile Strength at 200% elongation	ASTM D 412	≤10.3MPa
Tensile Strength After Aging (120°C, 168hrs)	SAE-AMS-DTL-23053	≥8.3MPa
Elongation at Break After Aging (120°C, 168hrs)	SAE-AMS-DTL-23053	≥175%
Dielectric Strength	ASTM D 2671	≥11.8kV/mm
Volume Resistivity	ASTM D 876	≥1x10 ¹¹ Ω.cm
Flammability (Self extinguishing 15 seconds;3 inches)	ASTM D2671,Procedure A	Pass
Fungus resistance	ASTM G 21	No growth
Low temperature flexibility	-70°C,4 hrs	No cracking

Selection Table

Product No.	As Supplied /mm	Recovered /mm	
		Inner Diameter	Wall thickness
WRS LD-3.2/1.5	≥3.2	≤1.5	0.7±0.2
WRS LD-4.8/2.5	≥4.8	≤2.5	0.8±0.2
WRS LD-6.4/3.4	≥6.4	≤3.4	0.9±0.2
WRS LD-9.5/5.4	≥9.5	≤5.4	1.0±0.2
WRS LD-12.7/7.1	≥12.7	≤7.1	1.2±0.3
WRS LD-16/8.7	≥16	≤8.7	1.3±0.3
WRS LD-19.1/10.5	≥19.1	≤10.5	1.4±0.3
WRS LD-22.2/12.5	≥22.2	≤12.5	1.7±0.3
WRS LD-25.4/14.5	≥25.4	≤14.5	1.8±0.3
WRS LD-31.8/18.0	≥31.8	≤18.0	2.2±0.3
WRS LD-38.1/21.5	≥38.1	≤21.5	2.4±0.3
WRS LD-44.5/24	≥44.5	≤24.0	2.4±0.3

WRSXP Heat Shrink Repair Sleeve

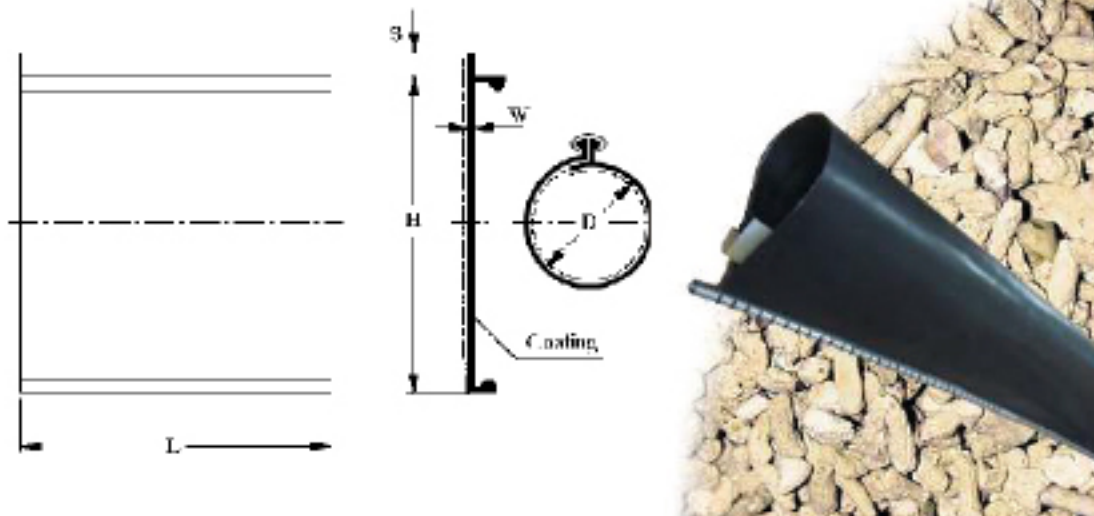

- Manufactured from polyolefin, inner coated with hot-melt adhesive.
- Providing fast and permanent repair and sealing protection for power cables.
- High tensile strength, abrasion and corrosion resistance.
- A corrosion proof metal channel is used to close the sleeve during installation.
- Shrink temperature: start at 90°C, and fully recovered at 130°C.

Selection Table

Spec.	As Supplied/mm		After Recovered/mm		Standard Length /mm
	Width(W) Min	Wall Thickness(T) (±0.3)	Width(W) Max	Wall Thickness(T) (±0.3)	
WRSXP-30/12	120	1.3	38	3.8	450-1200
WRSXP-40/12	130	1.2	38	3.8	450-1200
WRSXP-50/17	160	1.3	53	3.8	450-1200
WRSXP-65/24	205	1.2	75	3.8	450-1200
WRSXP-85/27	270	1.3	82	3.8	450-1200
WRSXP-100/27	320	1.4	82	3.8	450-1200
WRSXP-120/40	380	1.4	129	3.8	450-1000
WRSXP-150/50	475	1.4	157	3.8	450-1000
WRSXP-160/50	505	1.3	157	3.8	450-1000
WRSXP-170/51	535	1.2	160	3.8	450-1000
WRSXP-180/51	565	1.1	160	3.8	450-1000
WRSXP-195/52	590	1.0	163	3.8	450-1000

Technical Data

Property	Test Method	Standard Value
Tensile Strength	ASTM-D-638	≥ 12MPa
Elongation at Break	ASTM-D-638	≥ 300%
Tensile Strength Variation After Heat Aging (130°Cx168h)	ASTM-D-5510	≤ ± 20%
Elongation at Break Variation After Heat Aging (130°Cx168h)	ASTM-D-5510	≤ ± 20%
Dielectric Strength	IEC 60243	≥ 15kV/mm
Volume Resistivity	IEC 60093	≥ 1x10 ¹³ Ω.cm
Brittle Temperature	ISO 974	-40°C
Heat Shock	160°C, 4h	No Crack
Water Absorption	ISO 62	≤ 0.1%
Hardness (Shore A)	ISO 868	≥ 80
Longitudinal Shrinkage	ASTM-D-2671	≤ 10%
Eccentricity	ASTM-D-2671	≤ 30%

WMPG Heat Shrink Busbar Tube



- Manufactured from cross linked polyolefin.
- Used to offer insulation protection for busbar in switchgear and substation.
- Protects against short circuit and electrical leakage caused by small animals.
- Reduces busbar clearance requirements.
- RoHS compliant.
- Shrink temperature: start at 70°C, and fully recovered at 130°C.
- Color: yellow, red, green, blue, black .

Technical Data

Property	Test Method	Standard Value
Heat Shock	160°C, 4h	No Crack
Tensile Strength	ASTM-D-638	≥ 8MPa
Elongation at Break	ASTM-D-638	≥ 300%
Tensile Strength Variation After Heat Aging (130°Cx168h)	ASTM-D-5510	≤ ± 20%
Elongation at Break Variation After Heat Aging (130°Cx168h)	ASTM-D-5510	≤ ± 20%
Flammability (Oxygen Index)	IEC 4589	≥ 30%
Hardness (Shore A)	ISO 868	≤ 90

Electrical Property of Heat Shrink Busbar Tube

Item	Test Method	Standard Value	
		10kV	35kV
Volume Resistivity	IEC 60093	≥ 1x10 ¹⁴ Ω · cm	
Dielectric Strength	IEC 60243	≥ 25kV/mm	
Power Frequency Voltage Withstanding	DL/T 1059	42kV	95kV
Impulse Voltage	DL/T 1059	75kV	185kV



WRSZT

Heat Shrink Breakout



- Manufactured from cross-linked polyolefin.
- Provide sealing protection and strain relief over multi-core cable crutch, including 2-, 3-, 4-, and 5-core breakout.
- Coated with adhesive on the body and the fingers to form a watertight seal.
- Flame-retardant breakouts are available upon customer request.
- Meeting with varieties of configuration requirements.
- Shrink temperature: start at 90°C, and fully recovered at 130°C.

Technical Data

Property	Test Method	Standard Value		
		Insulated Breakout	Oil Resistant Breakout	Semi-conductive Breakout
Tensile Strength	ASTM-D-638	≥12MPa	≥12MPa	≥12MPa
Elongation at Break (120°C,168 hrs)	ASTM-D-638	≥300%	≥300%	≥300%
Tensile Strength after Aging (120°C,168 hrs)	ASTM-D-638	≥10MPa	≥10MPa	≥10MPa
Elongation at Break after Aging	ASTM-D-638	≥230%	≥230%	≥230%
Tensile Strength Variation after Dipping	ASTM-D-638	-	≤20%	-
Elongation at Break after Dipping	ASTM-D-638	-	≥230%	-
Dielectric Strength	IEC 60243	≥15kV/mm	≥15kV/mm	-
Water Absorption	ISO 62	≤0.1%	≤0.1%	≤0.1%
Volume Resistivity	IEC 60093	≥1×10 ¹³ Ω·cm	≥1×10 ¹³ Ω·cm	≤1×10 ³ Ω·cm
Brittle Temperature	ISO 974	-40°C	-40°C	-40°C
Heat Shock	160°C, 4h	No Crack	No Crack	No Crack
Hardness(Shore A)	ISO 868	≥80	≥80	≥80

Selection Table

Cores	Spec.	As Supplied (mm)			After Recovered	
		Body Diameter(D) Min	Finger Diameter(d) Min	Full Length (L)(±5)	Body Diameter(D) Max	Finger Diameter(d) Max
2-cores Breakout	WRSZT2-24/14(0#)	24	12	140	14	5
	WRSZT2-38/18(1#)	38	20	145	18	7
	WRSZT2-45/22(2#)	45	25	145	22	10
	WRSZT2-60/25(3#)	60	35	140	25	11
	WRSZT2-70/25(4#)	70	40	140	25	11
3-cores Breakout	WRSZT3-24/17(-2#)	24	11	140	17	5
	WRSZT3-48/22(-1#)	48	18	165	22	7
	WRSZT3-58/28(0#)	58	25	180	28	8
	WRSZT3-68/37(1#)*☆	68	30	210	37	13
	WRSZT3-87/43(2#)*☆	87	39	220	43	16
	WRSZT3-106/53(3#)*☆	106	42	235	53	19
	WRSZT3-125/65(4#)*☆	125	58	245	65	25
	WRSZT3-140/65(5#)*☆	140	65	245	65	25
4-cores Breakout	WRSZT4-38/19(0#)	38	10	125	19	5
	WRSZT4-50/25(1#)☆	50	16	135	25	7
	WRSZT4-70/32(2#)☆	70	23	185	32	10
	WRSZT4-82/46(3#)☆	82	30	210	46	13
	WRSZT4-90/46(4#)☆	90	35	210	46	13
	WRSZT4-109/54(5#)	109	42	240	54	18
5-cores Breakout	WRSZT5-42/21(0#)	42	11	130	21	5
	WRSZT5-57/30(1#)	57	15	170	30	7
	WRSZT5-70/38(2#)	70	23	170	38	9
	WRSZT5-90/53(3#)	90	30	180	53	13
	WRSZT5-120/48(4#)	120	39	205	48	14

- Remark: 1. * means 3-core semi-conductive breakouts are available upon custom request.
 2. ☆ means 3-core or 4-core oil resistant breakouts are available upon custom request.
 3. The breakout coated with hot-melt adhesive comes in two forms: flat adhesive and spiral adhesive, which can meet different customer needs.

WRSZT6

Heat Shrink 6-Core Breakout



- Made of cross linked polyolefin to provide mechanical protection and strain relief.
- Inner coated with adhesive on the body and the fingers to form a durable watertight seal.
- To provide sealing protection over 6-core cable crutch, such as trailing cable, variable frequency drive cable, telecommunication cables, control cable, etc.
- Shrink temperature: start at 90°C, and fully recovered at 130°C.

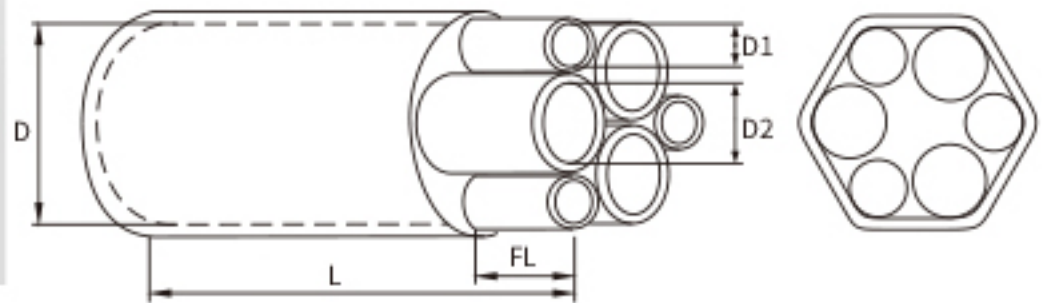

Selection Table

Cores	Spec.	As Supplied (mm)				After Recovered		
		Body Diameter(D) Min	Big Finger Diameter(d1) Min	Small Finger Diameter(d2) Min	Full Length (L)(±5)	Body Diameter(D) Max	Big Finger Diameter(d1) Max	Small Finger Diameter(d2) Max
6-cores Breakout	1#	84	30	20	215	41	11	8
	2#	132	55	31	225	53	16	11

Technical Data

Property	Test Method	Standard Value
Tensile Strength	ASTM-D-638	≥ 12MPa
Elongation at Break	ASTM-D-638	≥ 300%
Volume Resistivity	IEC 60093	≥ 1x10 ¹³ Ω.cm
Dielectric Strength	IEC 60243	≥ 15kV/mm
Brittle Temperature	ISO 974	-40°C
Heat Shock	160°C, 4h	No Crack
Water Absorption(23±2)°C 24h	ISO 62	≤ 0.1%
Hardness (Shore A)	ISO 868	≥ 80

WRSFM

Heat Shrink Cable End Cap

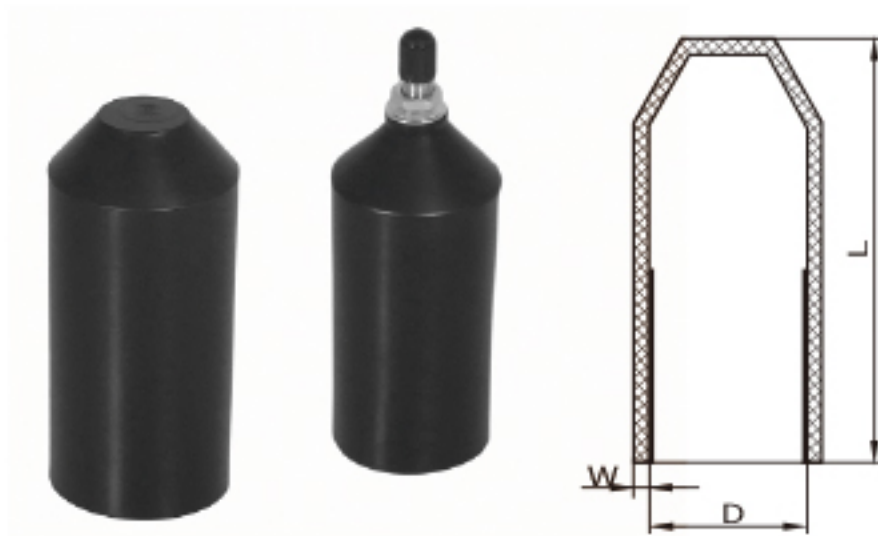

- Manufactured from polyolefin, applied as insulation of power and telecommunication cable ends.
- Used to seal cable ends during installation or storage, protecting cable ends against oxidation, ozone, UV, etc.
- Coated with hot-melt adhesive to ensure reliable seal of cable ends.
- Flame-retardant end caps are available upon customer request.
- Available with valve if required.
- Shrink temperature: start at 90°C, and fully recovered at 130°C.

Selection Table

Spec.	As Supplied (mm)			After Recovered	
	Inner Diameter (D) Min	Wall Thickness (T) ($\pm 20\%$)	Height (L) (± 5)	Inner Diameter (D) Max	Wall Thickness (T) ($\pm 10\%$)
WRSFM-12	12	1.0	45	5	2.5
WRSFM-16	16	1.0	70	8.5	2.5
WRSFM-20	20	1.0	70	8.5	2.5
WRSFM-25	25	1.0	80	11	2.5
WRSFM-30	30	1.3	95	16	2.8
WRSFM-35	35	1.0	95	18	2.6
WRSFM-40	40	1.1	95	18	2.6
WRSFM-55	55	1.0	125	26	2.7
WRSFM-75	75	1.3	145	31	3.2
WRSFM-100	97	1.3	140	40	5.2
WRSFM-120	117	1.3	155	57	4.0
WRSFM-140	140	1.3	185	63	4.0
WRSFM-160	158	2.1	270	95	4.0
WRSFM-180	180	2.1	270	95	4.0
WRSFM-200	200	1.5	270	95	4.0
WRSFM-250	245	1.5	270	95	4.0

Remark: The hot-melt adhesive comes in two forms: flat adhesive and spiral adhesive, which can meet different customer needs.

Technical Data

Property	Test Method	Standard Value
Tensile Strength	ASTM-D-638	$\geq 12\text{MPa}$
Elongation at Break	ASTM-D-638	$\geq 300\%$
Volume Resistivity	IEC 60093	$\geq 1 \times 10^{13} \Omega \cdot \text{cm}$
Dielectric Strength	IEC 60243	$\geq 15\text{kV/mm}$
Brittle Temperature	ISO 974	-40°C
Heat Shock	160°C, 4h	No Crack
Water Absorption(23 \pm 2)°C 24h	ISO 62	$\leq 0.1\%$
Hardness (Shore A)	ISO 868	≥ 80

AC Heat Shrink Anode Cap

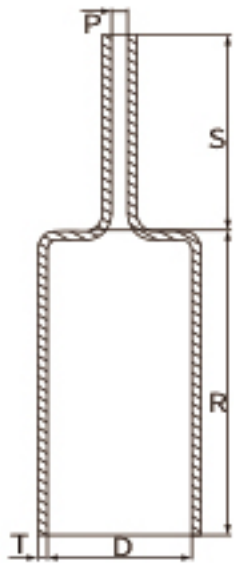

- Made of cross linked polyolefin, inner coated with adhesive.
- Sealing and protecting the critical connection between lead wire and anode.
- Ideal to avoid premature system failure due to loss of the wire to anode termination.
- Continuous operation temperature: -45°C to 105°C.

Selection Table

Spec.	As Supplied/mm					After Recovered/mm			
	D Min	d Min	T (± 0.3)	R (± 5)	S (± 5)	D Max	d Max	T (± 0.3)	
AC-66/48	2#	66	12	1.6	80	78	48	7	2.5
AC-87/63	3#B	87	12	2.0	105	80	63	7	2.7
AC-120/86	4#	120	13	2.0	100	77	86	8	2.7
AC-114/86	4#B	114	12	1.8	100	77	86	8	2.7
AC-50/30	$\phi 50$	50	20	1.8	45	105	30	6.5	3.2
AC-86/42	$\phi 86$	86	16	1.2	155	80	42	6.5	3.2
AC-112/58	$\phi 112$	112	16	1.2	150	80	58	6.5	3.2

Remark: The anode cap coated with hot-melt adhesive comes in two forms: plane adhesive and spiral adhesive, which can meet different customer needs.

Technical Data

Property	Test Method	Standard Value
Tensile Strength	ASTM-D-638	$\geq 12\text{MPa}$
Elongation at Break	ASTM-D-638	$\geq 300\%$
Volume Resistivity	IEC 60093	$\geq 1 \times 10^{13} \Omega \cdot \text{cm}$
Dielectric Strength	IEC 60243	$\geq 15\text{kV/mm}$
Brittle Temperature	ISO 974	-40°C
Hardness (Shore A)	ISO 868	≥ 80
Water Absorption(23 \pm 2)°C 24h	ISO 62	$\leq 0.1\%$
Heat Shock	160°C, 4h	No Crack

WRSSQ

Heat Shrink Anti-tracking Rain Shed



- Manufactured from polyolefin, coated with anti-tracking adhesive.
- High creep resistance and anti-tracking property.
- Shaped components to meet a range of requirement.

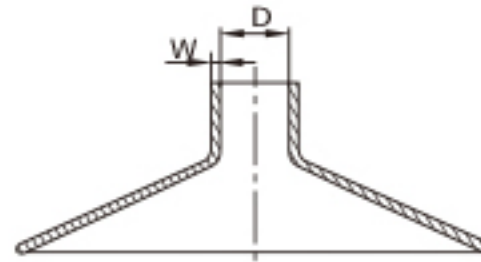

Selection Table

(1-core Rain Shed)

Spec.	As Supplied/mm		After Recovered/mm	
	Inner Diameter (D) (± 5)	Wall Thickness (T) ($\pm 20\%$)	Inner Diameter (D)Max	Wall Thickness (T)($\pm 10\%$)
WRSSQ-35/17	35	1.9	17	2.7
WRSSQ-40/24	40	1.9	24	2.7
WRSSQ-50/24	50	1.9	24	2.7
WRSSQ-60/32	60	2.4	32	4.0
WRSSQ-70/32	70	2.4	32	4.0

(3-core Rain Shed)

Spec.	As Supplied/mm		After Recovered/mm	
	Inner Diameter (D) (± 5)	Wall Thickness (T) ($\pm 20\%$)	Inner Diameter (D)Max	Wall Thickness (T)($\pm 10\%$)
WRSSQ-35/16	35	1.1	16	2.7
WRSSQ-45/22	45	1.1	22	3.0
WRSSQ-50/22	50	1.1	22	3.0

Technical Data

Property	Test Method	Standard Value
Tensile Strength	ASTM-D-638	≥ 8 MPa
Elongation at Break	ASTM-D-638	$\geq 300\%$
Tensile Strength Variation After Heat Aging (130°Cx168h)	ASTM-D-5510	$\leq \pm 30\%$
Elongation at Break Variation After Heat Aging (130°Cx168h)	ASTM-D-5510	$\leq \pm 30\%$
Volume Resistivity	IEC 60093	$\geq 1 \times 10^{13} \Omega \cdot \text{cm}$
Dielectric Strength	IEC 60243	≥ 20 kV/mm
Tracking Strength	IEC 60587	1A3.5
Dielectric Constant	IEC 60250	≤ 5
Heat Shock	160°C, 4h	No Crack
Water Absorption(23 \pm 2)°C 24h	ISO 62	$\leq 0.1\%$
Hardness (Shore A)	ISO 868	≥ 80
Brittle Temperature	ISO 974	-40°C

WRSRS

Heat Shrink Anti-tracking Rain Shed



- Manufactured from polyolefin, coated with anti-tracking adhesive.
- High creep resistance and anti-tracking property.
- Shaped components to meet a range of requirements.

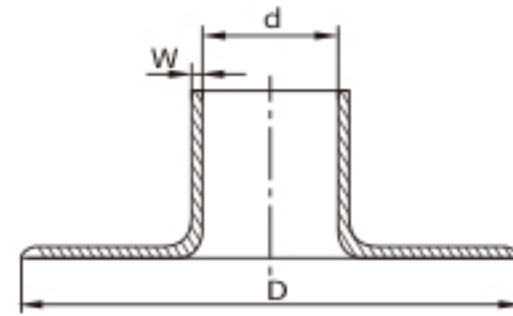

Selection Table

Spec.	D/mm (± 5)	As Supplied/mm		After Recovered/mm	
		Inner Diameter (d) (± 5)	Inner Diameter (d) Max	Wall Thickness (W) (± 0.4)	
WRSRS-30/12	90	30	12	2.8	
WRSRS-35/12	90	35	12	2.8	
WRSRS-40/20	120	40	20	2.8	
WRSRS-45/20	120	45	20	2.8	
WRSRS-50/20	120	50	20	2.8	
WRSRS-55/20	120	55	20	2.8	
WRSRS-60/20	120	60	20	2.8	
WRSRS-75/30	140	75	30	2.6	
WRSRS-80/30	140	80	30	2.6	

Technical Data

Property	Test Method	Standard Value
Tensile Strength	ASTM-D-638	≥ 8MPa
Elongation at Break	ASTM-D-638	≥ 300%
Tensile Strength Variation After Heat Aging (130°Cx168h)	ASTM-D-5510	≤ ± 30%
Elongation at Break Variation After Heat Aging (130°Cx168h)	ASTM-D-5510	≤ ± 30%
Volume Resistivity	IEC 60093	≥ 1x10 ¹⁴ Ω.cm
Dielectric Strength	IEC 60243	≥ 20kV/mm
Brittle Temperature	ISO 974	-40°C
Tracking Strength	IEC 60587	1A3.5
Dielectric Constant	IEC 60250	≤ 5
Heat Shock	160°C, 4h	No Crack
Water Absorption(23±2)°C 24h	ISO 62	≤ 0.1%
Hardness (Shore A)	ISO 868	≥ 80

WRSJX

Heat Shrink Right Angle/In-line Bushing Boot



- Manufactured from polyolefin, inner coated with hot-melt adhesive at the ends.
- Excellent insulation, flame retardant, thermal stability, etc.
- Used to protect cable against flashover or surges induced in switchgear and transformer.
- Shaped components to meet a range of requirements.

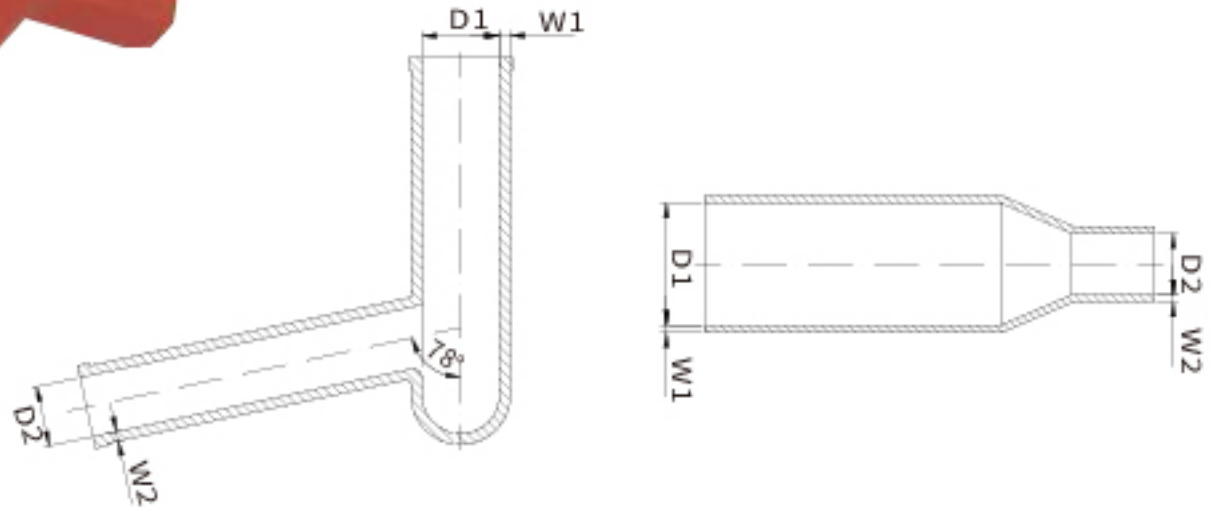

Selection Table

Spec.	As Supplied/mm		After Recovered/mm			
	D1 Min	D2 Min	D1 Max	D2 Max	W1 ($\pm 10\%$)	W2 ($\pm 10\%$)
Right Angle Boot						
WRSJX-R1	80	35	36	19	5.6	5.0
WRSJX-R2	80	50	36	19	5.6	5.0
WRSJX-R3	80	50	36	28	5.6	5.0
WRSJX-R4	95	70	36	28	5.6	5.0
WRSJX-R5	145	70	72	34	5.6	5.0
In-line Bushing Boot						
WRSJX-S1	80	34	32	19	3.6	3.6
WRSJX-S2	80	58	32	19	3.6	3.6
WRSJX-S3	140	90	68	34	3.6	3.6

Technical Data

Property	Test Method	Standard Value
Tensile Strength	ASTM-D-638	$\geq 10\text{MPa}$
Elongation at Break	ASTM-D-638	$\geq 300\%$
Tensile Strength Variation After Heat Aging (130°Cx168h)	ASTM-D-5510	$\leq \pm 20\%$
Elongation at Break Variation After Heat Aging (130°Cx168h)	ASTM-D-5510	$\leq \pm 20\%$
Volume Resistivity	IEC 60093	$\geq 1 \times 10^{14} \Omega \cdot \text{cm}$
Dielectric Strength	IEC 60243	$\geq 25\text{kV/mm}$

WRSLT Heat Shrink Cable Entry Seal



- Made of flame-retardant polyolefin, inner coated with adhesive to provide sealing protection.
- Provides a watertight and fume-tight seal where cables enter connection boxes, bulkheads, or other enclosures.
- Consists of a three-part assembly- a rigid plastic nut, O-ring, and a heat shrink moulded body.
- Continuous operation temperature: -55°C to 90°C.

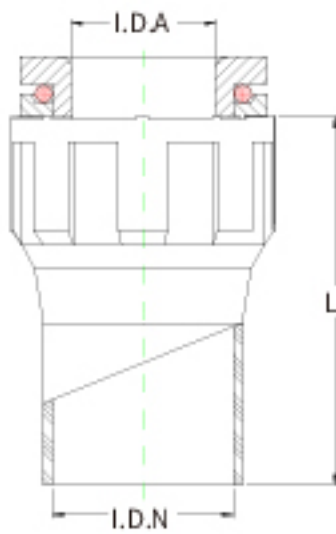

Selection Table

Part Number	As Supplied Length (L)(±5mm)	As Supplied Nose I.D. ((I.D.N,Min)/mm)	After Recovered Nose I.D. (I.D.N,Max)/mm	Body I.D(I.D.A,±5mm)
WRSLT-4	95	45	19	41
WRSLT-5	162	70	36	74

Technical Data

Property	Test Method	Standard Value
Tensile Strength	ASTM-D-2671	≥ 10MPa
Elongation at Break	ASTM-D-2671	≥ 300%
Tensile Strength Variation After Heat Aging (130°Cx168h)	ASTM-D-5510	≤ ± 20%
Elongation at Break Variation After Heat Aging (130°Cx168h)	ASTM-D-5510	≤ ± 20%
Water Absorption	ISO 62	≤ 0.1%
Dielectric Strength	IEC 60243	≥ 20kV/mm
Volume Resistivity	IEC 60093	≥ 1x10 ¹⁴ Ω.cm

WRSY Heat Shrink Y-type Tube

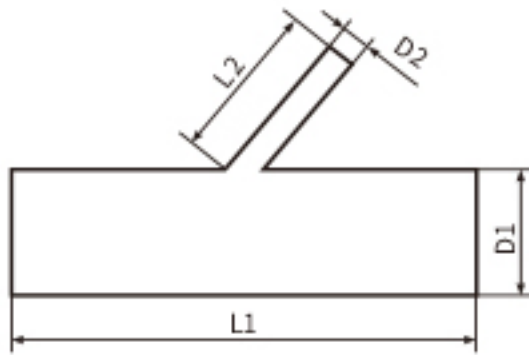

- Made of cross-linked polyolefin.
- Mostly used to provide sealing and protection for bifurcated cable, especially for the branch cable lapping on the main cable.
- Shrink temperature: start at 90°C , and fully recovered at 130°C.

Selection Table

Product No.	L1/±5mm	L2/±3mm	D1/mm		D2/mm	
			As Supplied	After Recovered	As Supplied	After Recovered
WRSY-28/13	120	38	≥ 28	≤ 13	≥ 9	≤ 4

Technical Data

Property	Test Method	Standard Value
Tensile Strength	ASTM-D-638	≥ 10MPa
Elongation at Break	ASTM-D-638	≥ 300%
Dielectric Strength	IEC 60243	≥ 20kV/mm
Volume Resistivity	IEC 60093	≥ 1×10 ¹³ Ω · cm



Technical Data

Property		Test Method	Standard Value
Physical properties	Tensile Strength	ASTM-D-2671	≥12MPa
	Elongation at Break	ASTM-D-2671	≥350%
	Tensile Strength after Aging	ISO 868	≥10MPa
	Elongation at Break after Aging (130°C, 168h)	ASTM-D-2671	≥280%
	Heat shock (200°C, 4h)	UL 224	No dripping, flowing or cracking
	Low temperature flexibility	ISO 974	-40°C
Oxygen index		ISO 4589	≥28
Dielectric strength		IEC 60243	≥20kV/mm
Solvent resistance (23°C, 24h)	Gasoline	Tensile strength	≥10MPa
		Elongation at break	≥280%
	Diesel oil	Tensile strength	≥10MPa
		Elongation at break	≥280%
	Acid & alkali	Tensile strength	≥10MPa
		Elongation at break	≥280%

Z11 Heat Shrink Cable Straight Boot



Features

- Made of semi-rigid flame-retarded polyolefin.
- Used for strong mechanical protection, connector/cable strain relief, and complete environmental sealing.
- This family of boots has no lip.
- Provided with or without adhesive lining.
- Standard colour: Black.

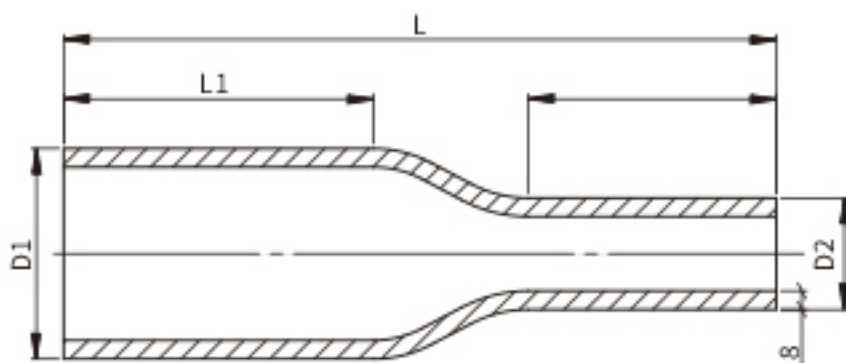

After unrestricted recovery (b)

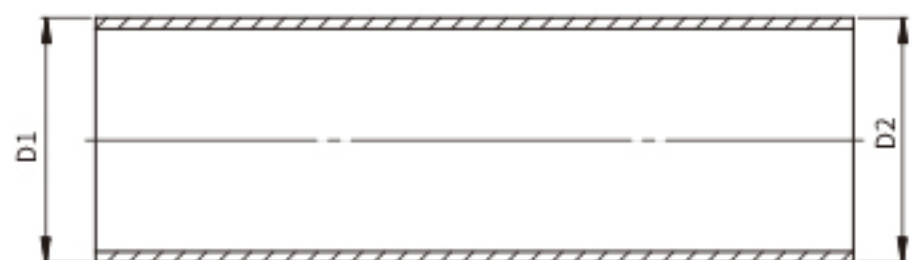

As supplied (a)

Selection Table

Product No.	Specification	D ₁			D ₂			L ±10%	L ₁ ±10%	L ₂ ±10%	δ ±20%
		As Supplied	After Recovered	Range Of Application	As Supplied	After Recovered	Range Of Application				
Z1131	24/11-5.6	24	11.0	14.0-20.0	24	5.6	7.0-14.0	50	27	16	2.0

unit mm

W11 Heat Shrink Right Angled Boot



Features

- Made of semi-rigid flame-retarded polyolefin.
- Provide strong mechanical protection, connector/cable strain relief, and complete environmental sealing.
- This family of boots has no lip.
- Provided with or without adhesive lining.
- Standard colour: Black.

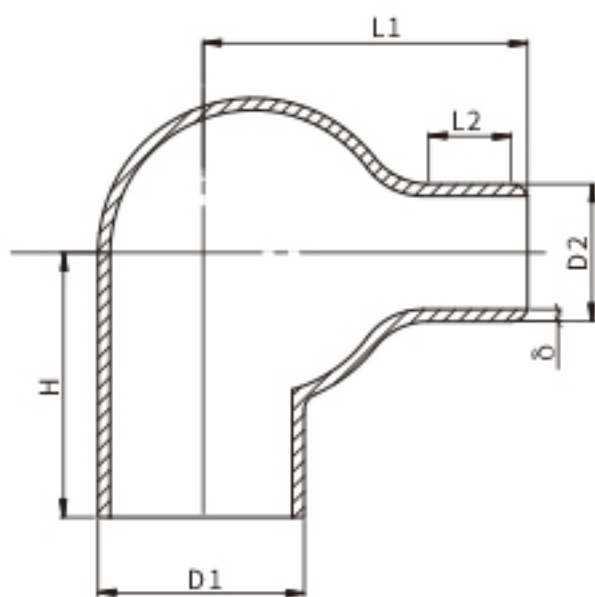

After unrestricted recovery (b)



As supplied (a)

Selection Table

Product No.	Specification	D ₁			D ₂			H	L ₁ ±10%	L ₂ ±10%	δ ±20%
		As Supplied	After Recovered	Range Of Application	As Supplied	After Recovered	Range Of Application				
W1121	22/11-5	22	11	13.0-18.5	22	5.0	6.2-12.0	27	36	18	2.0

unit mm

C21 Heat Shrink 2-way Outlet Shapes



Features

- Made of semi-rigid flame-retarded polyolefin.
- Provide strong mechanical protection, strain relief, and complete environmental sealing on cable harness assemblies.
- Provided with or without adhesive lining.
- Standard colour: Black.

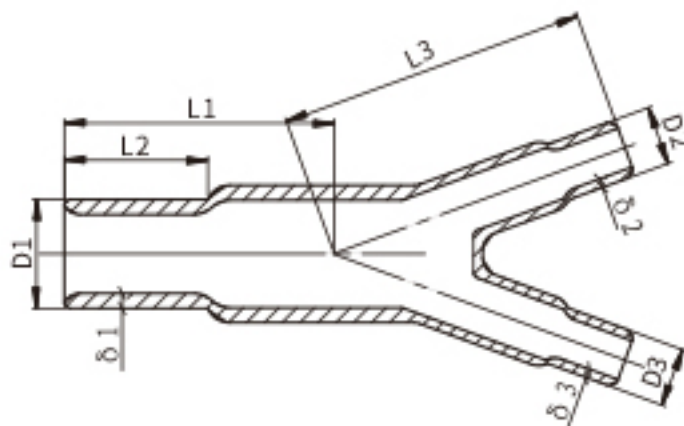

After unrestricted recovery (b)

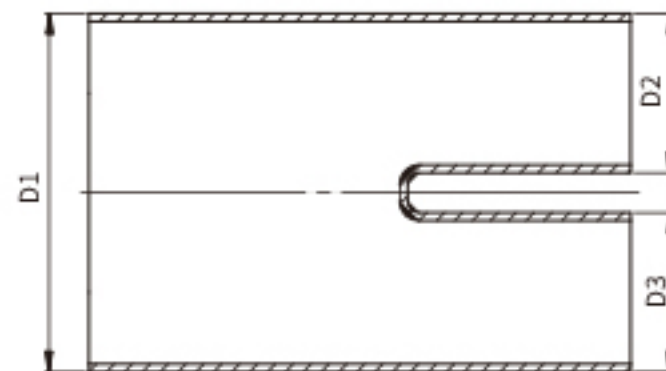

As supplied (a)

Selection Table

Product No.	D ₁		D _{2,3}		L ₁ ±10%	L ₂ ±10%	L ₃ ±10%	δ ₁ ±20%	δ _{2,3} ±20%
	As Supplied	After Recovery	As Supplied	After Recovery					
C2111	13.5	6.0	6.6	3.3	24.0	15.5	25	2.0	1.5
C2121	27.0	12.4	13.2	6.1	53.3	33.0	55	2.5	2.0

unit mm

C31 Heat Shrink 3-way Outlet Shapes



Features

- Made of semi-rigid flame-retarded polyolefin.
- Provide strong mechanical protection, strain relief, and complete environmental sealing on cable harness assemblies.
- Provided with or without adhesive lining.
- Standard colour: Black.

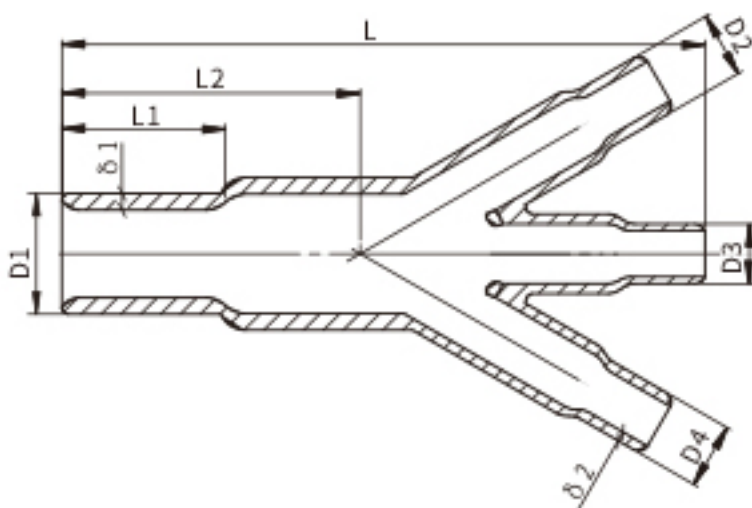

After unrestricted recovery (b)

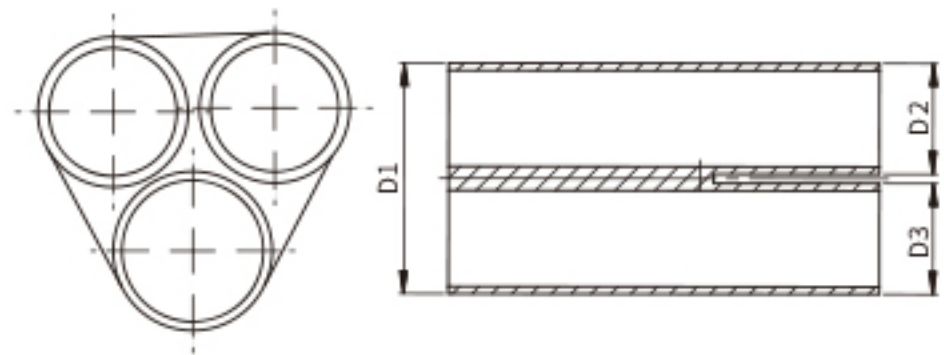

As supplied (a)

Selection Table

Product No.	D ₁		D _{2,3,4}		L ±10%	L1 ±10%	L2 ±10%	δ ₁ ±20%	δ ₂ ±20%
	As Supplied	After Recovery	As Supplied	After Recovery					
C3111	14	6.6	6.6	3.6	46	15.7	31	2.0	1.5
C3121	27	13.2	13.2	6.9	94	33.0	57	2.5	2.0

unit mm

WLN, WLW Cold Shrink Termination up to 42 kV

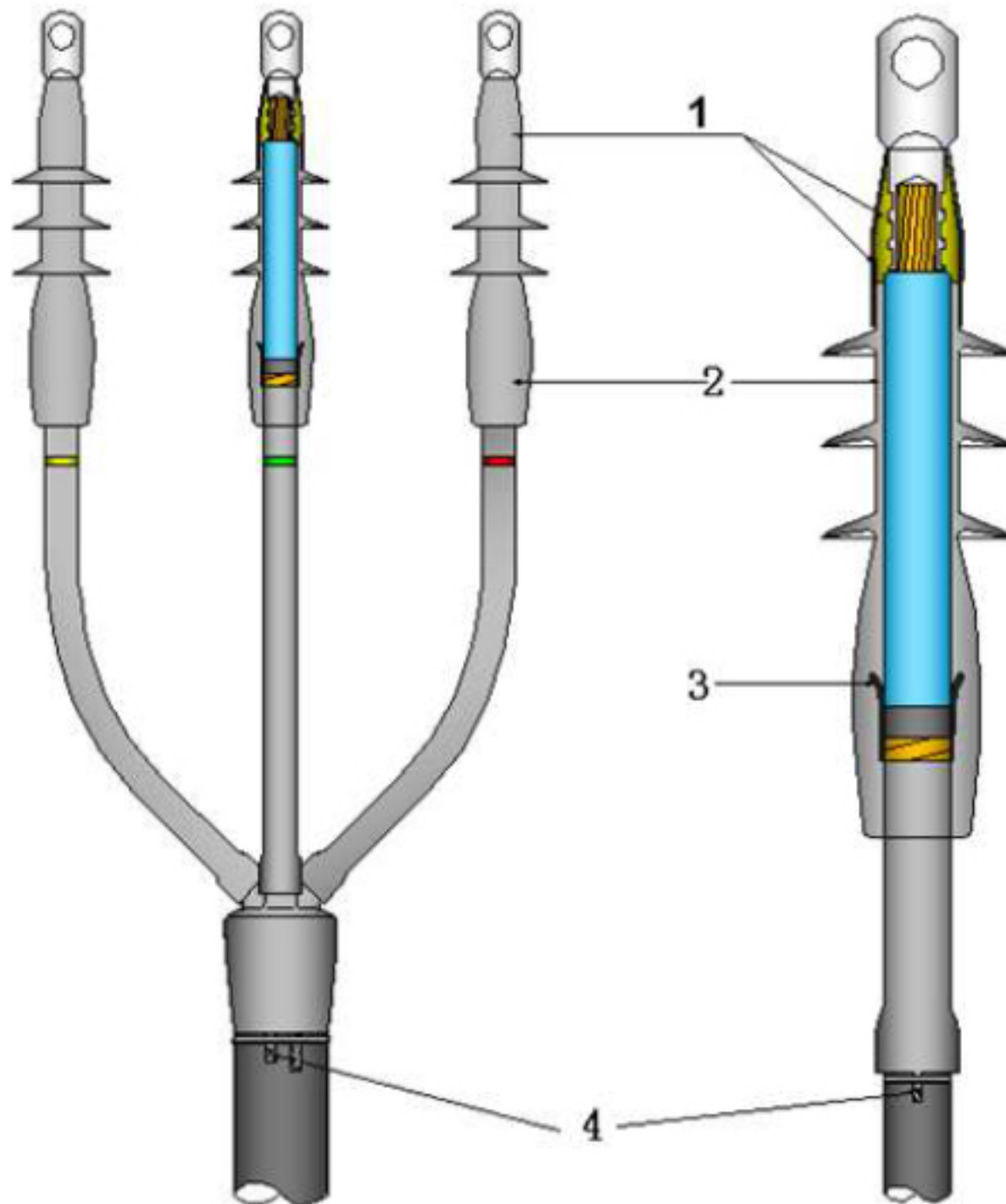

Features:

- 1. Environmental top sealing treatment**
Three steps to provide a seal against the entrance of the external environment.
- 2. Excellent external housing**
Imported LSR offers excellent hydrophobicity and great anti-tracking property to ensure the power safety.
- 3. Stress control**
Stress cone adopts well designed geometric analysis to smooth out the high stress-intense area.
- 4. Earth connection**
Adopt Solderless earth connection to connect metal screen or armour to ground. For cables with wire screen, copper wires are imbedded in the sealing mastic to prevent any corrosion by moisture ingress.

Note:

Terminations can be ordered as standard kits (without lugs) or complete kits.
Terminations and components for other cable types are available on request.

Selection Table

Voltage $U_0 / U(U_n)$	Cores	Cable Cross Section /mm ²	Nominal Insulation Thickness /mm	Diameter over Insulation /mm	Kit No.
0.6/1(1.2)kV	1,2,3,4,5 Indoor or Outdoor	10-25 35-50 70-95 120-150 185-240 300-400	—	—	1.2kVWLT-1(2,3,4,5)/0 1.2kVWLT-1(2,3,4,5)/1 1.2kVWLT-1(2,3,4,5)/2 1.2kVWLT-1(2,3,4,5)/3 1.2kVWLT-1(2,3,4,5)/4 1.2kVWLT-1(2,3,4,5)/5
6/10(12)kV 6.35/11(12)kV	1,3 Indoor	25-35 50-70 95-150 185-300 400-500 630	3.4	13.5-16 16-19.5 19-24.5 23.5-30 30.5-35 37-42.3	12kVWLN-1/0(3/0) 12kVWLN-1/1(3/1) 12kVWLN-1/2(3/2) 12kVWLN-1/3(3/3) 12kVWLN-1/4(3/4) 12kVWLN-1/5(3/5)
	1,3 Outdoor	25-35 50-70 95-150 185-300 400-500 630	3.4	13.5-16 16-19.5 19-24.5 23.5-30 30.5-35 37-42.3	12kVWLW-1/0(3/0) 12kVWLW-1/1(3/1) 12kVWLW-1/2(3/2) 12kVWLW-1/3(3/3) 12kVWLW-1/4(3/4) 12kVWLW-1/5(3/5)
8.7/15(17.5)kV	1,3 Indoor	16 25-50 70-120 150-240 300-400 500-630	4.5	13.5-16 16-19.5 19-24.5 23.5-30 30.5-35 37-42.3	17.5kVWLN-1/0(3/0) 17.5kVWLN-1/1(3/1) 17.5kVWLN-1/2(3/2) 17.5kVWLN-1/3(3/3) 17.5kVWLN-1/4(3/4) 17.5kVWLN-1/5(3/5)
	1,3 Outdoor	16 25-50 70-120 150-240 300-400 500-630	4.5	13.5-16 16-19.5 19-24.5 23.5-30 30.5-35 37-42.3	17.5kVWLW-1/0(3/0) 17.5kVWLW-1/1(3/1) 17.5kVWLW-1/2(3/2) 17.5kVWLW-1/3(3/3) 17.5kVWLW-1/4(3/4) 17.5kVWLW-1/5(3/5)
12/20(24)kV 12.7/22(24)kV	1,3 Indoor	25-50 70-120 150-240 300-400 500-630	5.5	18.5-21 21.5-26 26.5-32 32.5-37 37.5-44	24kVWLN-1/1(3/1) 24kVWLN-1/2(3/2) 24kVWLN-1/3(3/3) 24kVWLN-1/4(3/4) 24kVWLN-1/5(3/5)
	1,3 Outdoor	25-50 70-120 150-240 300-400 500-630	5.5	18.5-21 21.5-26 26.5-32 32.5-37 37.5-44	24kVWLW-1/1(3/1) 24kVWLW-1/2(3/2) 24kVWLW-1/3(3/3) 24kVWLW-1/4(3/4) 24kVWLW-1/5(3/5)
18/30(36)kV 19/33(36)kV	1,3 Indoor	35-50 70-95 120-185 240-500 630	8.0	23.5-26 27-30 30-35 34.5-45 45.5-50	36kVWLN-1/1(3/1) 36kVWLN-1/2(3/2) 36kVWLN-1/3(3/2) 36kVWLN-1/4(3/3) 36kVWLN-1/5(3/4)
	1,3 Outdoor	35-50 70-95 120-185 240-500 630	8.0	23.5-26 27-30 30-35 34.5-45 45.5-50	36kVWLW-1/1(3/1) 36kVWLW-1/2(3/2) 36kVWLW-1/3(3/2) 36kVWLW-1/4(3/3) 36kVWLW-1/5(3/4)
20.8/36(42)kV	1,3 Indoor	50-95 120-240 300-400 500-630	9.3	29-34.5 35-41.5 42-47.5 48-54	42kVWLN-1/1(3/1) 42kVWLN-1/2(3/2) 42kVWLN-1/3(3/3) 42kVWLN-1/4(3/4)
	1,3 Outdoor	50-95 120-240 300-400 500-630	9.3	29-34.5 35-41.5 42-47.5 48-54	42kVWLW-1/1(3/1) 42kVWLW-1/2(3/2) 42kVWLW-1/3(3/3) 42kVWLW-1/4(3/4)
26/35(42)kV	1,3 Indoor	50-95 120-240 300-400 500-630	10.5	29-34.5 35-41.5 42-47.5 48-54	42kVWLN-1/1(3/1) 42kVWLN-1/2(3/2) 42kVWLN-1/3(3/3) 42kVWLN-1/4(3/4)
	1,3 Outdoor	50-95 120-240 300-400 500-630	10.5	29-34.5 35-41.5 42-47.5 48-54	42kVWLW-1/1(3/1) 42kVWLW-1/2(3/2) 42kVWLW-1/3(3/3) 42kVWLW-1/4(3/4)

WLN, WLW Cold Shrink Termination up to 42 kV

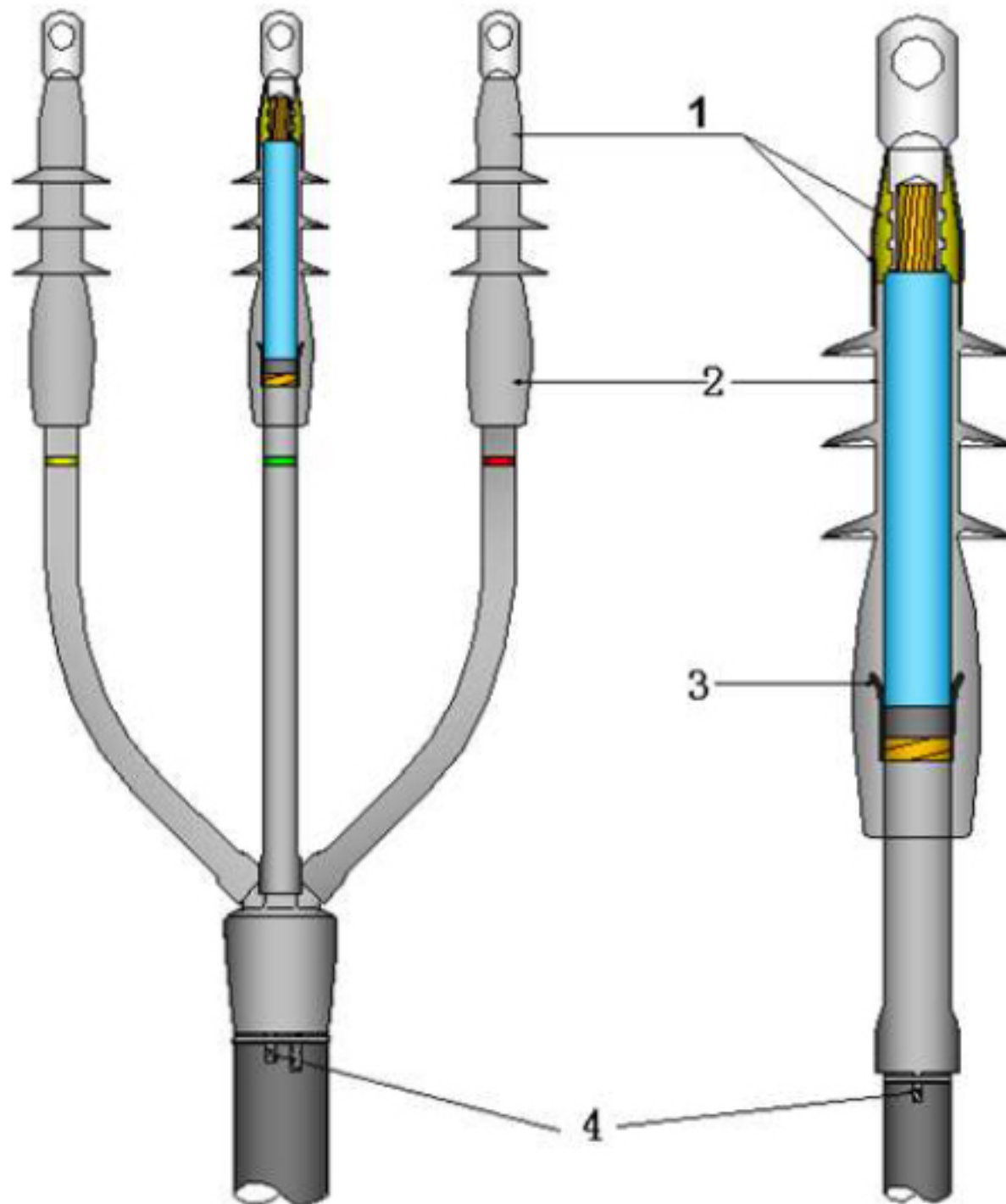

Features:

- 1. Environmental top sealing treatment**
Three steps to provide a seal against the entrance of the external environment.
- 2. Excellent external housing**
Imported LSR offers excellent hydrophobicity and great anti-tracking property to ensure the power safety.
- 3. Stress control**
Stress cone adopts well designed geometric analysis to smooth out the high stress-intense area.
- 4. Earth connection**
Adopt Solderless earth connection to connect metal screen or armour to ground. For cables with wire screen, copper wires are imbedded in the sealing mastic to prevent any corrosion by moisture ingress.

Note:

Terminations can be ordered as standard kits (without lugs) or complete kits.
Terminations and components for other cable types are available on request.

Selection Table

Voltage $U_0 / U(U_n)$	Cores	Cable Cross Section /mm ²	Nominal Insulation Thickness /mm	Diameter over Insulation /mm	Kit No.
0.6/1(1.2)kV	1,2,3,4,5 Indoor or Outdoor	10-25	—	—	1.2kVWLT-1(2,3,4,5)/0 1.2kVWLT-1(2,3,4,5)/1 1.2kVWLT-1(2,3,4,5)/2 1.2kVWLT-1(2,3,4,5)/3 1.2kVWLT-1(2,3,4,5)/4 1.2kVWLT-1(2,3,4,5)/5
		35-50 70-95 120-150 185-240 300-400			
6/10(12)kV 6.35/11(12)kV	1,3 Indoor	25-35 50-70 95-150 185-300 400-500 630	3.4	13.5-16 16-19.5 19-24.5 23.5-30 30.5-35 37-42.3	12kVWLN-1/0(3/0) 12kVWLN-1/1(3/1) 12kVWLN-1/2(3/2) 12kVWLN-1/3(3/3) 12kVWLN-1/4(3/4) 12kVWLN-1/5(3/5)
	1,3 Outdoor	25-35 50-70 95-150 185-300 400-500 630			
8.7/15(17.5)kV	1,3 Indoor	16 25-50 70-120 150-240 300-400 500-630	4.5	13.5-16 16-19.5 19-24.5 23.5-30 30.5-35 37-42.3	17.5kVWLN-1/0(3/0) 17.5kVWLN-1/1(3/1) 17.5kVWLN-1/2(3/2) 17.5kVWLN-1/3(3/3) 17.5kVWLN-1/4(3/4) 17.5kVWLN-1/5(3/5)
	1,3 Outdoor	16 25-50 70-120 150-240 300-400 500-630			
12/20(24)kV 12.7/22(24)kV	1,3 Indoor	25-50 70-120 150-240 300-400 500-630	5.5	18.5-21 21.5-26 26.5-32 32.5-37 37.5-44	24kVWLN-1/1(3/1) 24kVWLN-1/2(3/2) 24kVWLN-1/3(3/3) 24kVWLN-1/4(3/4) 24kVWLN-1/5(3/5)
	1,3 Outdoor	25-50 70-120 150-240 300-400 500-630			
18/30(36)kV 19/33(36)kV	1,3 Indoor	35-50 70-95 120-185 240-500 630	8.0	23.5-26 27-30 30-35 34.5-45 45.5-50	36kVWLN-1/1(3/1) 36kVWLN-1/2(3/2) 36kVWLN-1/3(3/2) 36kVWLN-1/4(3/3) 36kVWLN-1/5(3/4)
	1,3 Outdoor	35-50 70-95 120-185 240-500 630			
20.8/36(42)kV	1,3 Indoor	50-95 120-240 300-400 500-630	9.3	29-34.5 35-41.5 42-47.5 48-54	42kVWLN-1/1(3/1) 42kVWLN-1/2(3/2) 42kVWLN-1/3(3/3) 42kVWLN-1/4(3/4)
	1,3 Outdoor	50-95 120-240 300-400 500-630			
26/35(42)kV	1,3 Indoor	50-95 120-240 300-400 500-630	10.5	29-34.5 35-41.5 42-47.5 48-54	42kVWLN-1/1(3/1) 42kVWLN-1/2(3/2) 42kVWLN-1/3(3/3) 42kVWLN-1/4(3/4)
	1,3 Outdoor	50-95 120-240 300-400 500-630			

WLJ

Cold Shrink Joint up to 42 kV

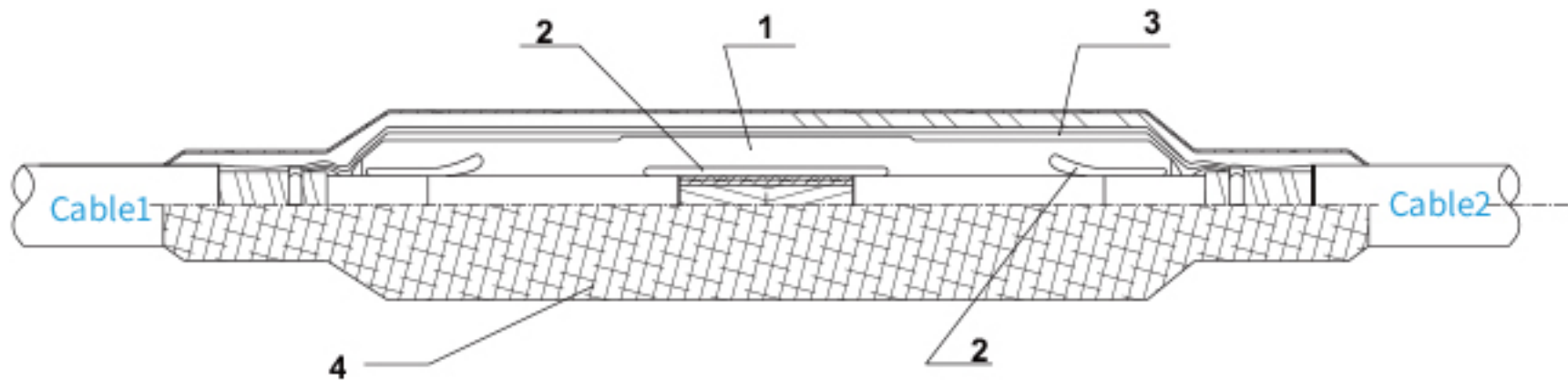

1. Joint Body

One-piece design to provide the stress control, insulation and insulation screen to rebuild the cable structure.

2. Electrical stress control

Stress control tube, together with stress cone are used to smooth out the electrical field at the screen cuts.

3. Metallic shielding

Copper mesh which has been secured with solderless earth connection is wrapped around the joint area to rebuild the metallic screen and provide screen continuity across the joint.

4. Outer sealing and protection

The outer sealing and protection is performed by both the waterproof tape and armour tape. So they provide mechanical protection and chemical resistance as expected from cable oversheath.

Note:

Joints can be ordered as standard kits (without connectors) or complete kits.

Joints and components for other cable types are available on request.

Connectors shall be ordered separately.



Selection Table

Voltage U_0/U (U_m)	Cores	Cable Cross Section/ mm^2	Nominal Insulation Thickness /mm	Diameter over Insulation/mm	Kit No.
0.6/1(1.2)kV	1, 2, 3, 4, 5	10-25 35-50 70-95 120-150 185-240 300-400	—	—	1.2kVWLJ-1(2,3,4,5)/0 1.2kVWLJ-1(2,3,4,5)/1 1.2kVWLJ-1(2,3,4,5)/2 1.2kVWLJ-1(2,3,4,5)/3 1.2kVWLJ-1(2,3,4,5)/4 1.2kVWLJ-1(2,3,4,5)/5
6/10(12)kV 6.35/11(12)kV	1, 3	50-70 95-150 185-300 400-500 630	3.4	16-19.5 19-24.5 23.5-30 30.5-35 37-42.3	12kVWLJ-1/1(3/1) 12kVWLJ-1/2(3/2) 12kVWLJ-1/3(3/3) 12kVWLJ-1/4(3/4) 12kVWLJ-1/5(3/5)
8.7/15(17.5)kV	1, 3	25-50 70-120 150-240 300-400 500-630	4.5	16.5-19.5 19-24.5 23.5-30 30.5-35 37-42.3	17.5kVWLJ-1/1(3/1) 17.5kVWLJ-1/2(3/2) 17.5kVWLJ-1/3(3/3) 17.5kVWLJ-1/4(3/4) 17.5kVWLJ-1/5(3/5)
12/20(24)kV 12.7/22(24)kV	1, 3	25-50 70-120 150-240 300-400 500-630	5.5	18.5-21 21.5-26 26.5-32 32.5-37 37.5-44	24kVWLJ-1/1(3/1) 24kVWLJ-1/2(3/2) 24kVWLJ-1/3(3/3) 24kVWLJ-1/4(3/4) 24kVWLJ-1/5(3/5)
18/30(36)kV 19/33(36)kV	1, 3	35-50 70-120 150-240 300-400 500-630	8.0	23.5-26 26.5-31 31.5-37 37.5-42 42.5-50	36kVWLJ-1/1(3/1) 36kVWLJ-1/2(3/2) 36kVWLJ-1/3(3/3) 36kVWLJ-1/4(3/4) 36kVWLJ-1/5(3/5)
20.8/36(42)kV	1, 3	50-95 120-240 300-400 500-630	9.3	29-34.5 35-41.5 42-47.5 48-54	42kVWLJ-1/1(3/1) 42kVWLJ-1/2(3/2) 42kVWLJ-1/3(3/3) 42kVWLJ-1/4(3/4)
26/35(42)kV	1, 3	50-95 120-240 300-400 500-630	10.5	29-34.5 35-41.5 42-47.5 48-54	42kVWLJ-1/1(3/1) 42kVWLJ-1/2(3/2) 42kVWLJ-1/3(3/3) 42kVWLJ-1/4(3/4)

WCST

Cold Shrink Silicone Rubber Tube



- Manufactured from silicone rubber.
- Offering good mechanical, insulation and sealing protection.
- Accommodating a wide range of cable sizes.
- For indoor or outdoor applications.
- Simple and fast installation.
- Color: grey, black.

Selection Table

Spec.	ID before shrunk ΦD/mm	After fully shrunk		Range/mm
		Length/mm	Thickness/mm	
WCST15	15±2	80~450	2.0±0.2	Φ6~Φ8
WCST20	20±2	80~450	2.0±0.2	Φ10~Φ14
WCST25	25±2	80~500	2.5±0.2	Φ12~Φ17
WCST32	32±2	80~490	2.5±0.2	Φ14~Φ21
WCST35	35±2	80~1000	2.0±0.2	Φ19~Φ28
WCST40	40±2	80~1000	2.0±0.2	Φ21~Φ31
WCST47	47±2	80~1000	2.0±0.2	Φ25~Φ37
WCST53	53±2	80~1000	2.0±0.2	Φ31~Φ45
WCST65	65±2	80~1000	3.0±0.2	Φ31~Φ50
WCST70	70±3	80~500	3.0±0.2	Φ37~Φ55
WCST80	80±3	80~500	3.0±0.2	Φ44~Φ65
WCST104	104±3	80~500	3.0±0.2	Φ51~Φ84
WCST120	120±3	80~420	3.0±0.2	Φ55~Φ100

Remark: ID* means inner diameter.

WEPDMC

Cold Shrink EPDM Tube



- Manufactured from EPDM rubber.
- Offering good mechanical, insulation and sealing protection.
- Accommodating a wide range of cable sizes.
- For indoor or outdoor applications.
- Simple and fast installation.

Selection Table

Cold Shrink Tube of General EPDM					
Product No.	Size	Application Range (mm/inch)	Length after Relaxed(mm/inch)	Material	Color
8320-L	Φ20	8~15/0.30~0.59	50~550/2~22	EPDM Rubber	Black
8325-L	Φ25	10~20/0.39~0.79	50~550/2~22	EPDM Rubber	Black
8335-L	Φ35	14~30/0.55~1.18	50~550/2~22	EPDM Rubber	Black
8340-L	Φ40	17.5~33/0.69~1.30	50~550/2~22	EPDM Rubber	Black
8353-L	Φ53	25~46/0.98~1.81	50~550/2~22	EPDM Rubber	Black
8370-L	Φ70	32~63/1.26~2.48	50~470/2~18	EPDM Rubber	Black
8104-L	Φ104	43~94/1.69~3.70	50~470/2~18	EPDM Rubber	Black
8125-L	Φ125	46~114/1.81~4.49	50~470/2~18	EPDM Rubber	Black
8150-L	Φ150	55~135/2.17~5.31	50~470/2~18	EPDM Rubber	Black

Cold Shrink Tube of High Shrinkage Ratio EPDM					
Product No.	Size	Application Range (mm/inch)	Length after Relaxed(mm/inch)	Material	Color
8435-L	Φ35	12.5~30/0.49~1.18	50~550/2~22	EPDM Rubber	Black
8440-L	Φ40	14~33/0.55~1.30	50~550/2~22	EPDM Rubber	Black
8453-L	Φ53	19~46/0.75~1.81	50~550/2~22	EPDM Rubber	Black
8470-L	Φ70	25~63/0.98~2.48	50~470/2~18	EPDM Rubber	Black
8480-L	Φ80	27.4~70/1.08~2.75	50~470/2~18	EPDM Rubber	Black

Remark: L indicates the required length after relaxed with the unit of mm or inch.

WCSF

Cold Shrink Silicone Rubber Breakout



- Manufactured from silicone rubber.
- Simple and fast installation meeting a variety of configuration requirements.
- Providing sealing protection over multi-core cable crutch, including 2-, 3-, 4-, 5-, 6-core breakouts.

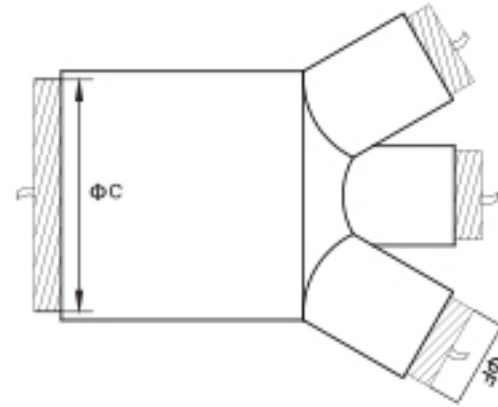

Specification

Spec.	ID before shrunk/mm		ID after shrunk/mm		
	Finger ϕF	Body ϕC	Finger ϕF	Body ϕC	
2-core breakout	WCSF 2-1(1#)	$\phi 20 \pm 2$	$\phi 47 \pm 2$	$\phi 7^{+3}_0$ mm	$\phi 14^{+3}_0$ mm
	WCSF 2-2(2#)	$\phi 25 \pm 2$	$\phi 65 \pm 2$	$\phi 9^{+3}_0$ mm	$\phi 19^{+3}_0$ mm
	WCSF 2-3(3#)	$\phi 32 \pm 2$	$\phi 80 \pm 2$	$\phi 12^{+3}_0$ mm	$\phi 25^{+3}_0$ mm
	WCSF 2-4(4#)	$\phi 47 \pm 2$	$\phi 110 \pm 3$	$\phi 17^{+3}_0$ mm	$\phi 35^{+3}_0$ mm
3-core breakout	WCSF 3-(-1)(-1#)	$\phi 20 \pm 2$	$\phi 56 \pm 2$	$\phi 9^{+3}_0$ mm	$\phi 19^{+3}_0$ mm
	WCSF 3-(-2)(-2#)	$\phi 25 \pm 2$	$\phi 65 \pm 2$	$\phi 10^{+3}_0$ mm	$\phi 23^{+3}_0$ mm
	WCSF 3-1(1#)	$\phi 32 \pm 2$	$\phi 80 \pm 2$	$\phi 15^{+3}_0$ mm	$\phi 37^{+3}_0$ mm
	WCSF 3-2(2#)	$\phi 35 \pm 2$	$\phi 88 \pm 2$	$\phi 17^{+3}_0$ mm	$\phi 44^{+3}_0$ mm
	WCSF 3-3(3#)	$\phi 40 \pm 2$	$\phi 104 \pm 2$	$\phi 20^{+3}_0$ mm	$\phi 51^{+3}_0$ mm
	WCSF 3-4(4#)	$\phi 47 \pm 2$	$\phi 120 \pm 2$	$\phi 24^{+3}_0$ mm	$\phi 60^{+3}_0$ mm
	WCSF 3-5(5#)	$\phi 60 \pm 2$	$\phi 140 \pm 2$	$\phi 28^{+3}_0$ mm	$\phi 73^{+3}_0$ mm
	WCSF 3-6(6#)	$\phi 65 \pm 2$	$\phi 150 \pm 2$	$\phi 30^{+3}_0$ mm	$\phi 75^{+3}_0$ mm
	WCSF 3-7(7#)	$\phi 70 \pm 2$	$\phi 165 \pm 2$	$\phi 30^{+3}_0$ mm	$\phi 75^{+3}_0$ mm
4-core breakout	WCSF 4-1(1#)	$\phi 20 \pm 2$	$\phi 60 \pm 2$	$\phi 7^{+3}_0$ mm	$\phi 21^{+3}_0$ mm
	WCSF 4-2(2#)	$\phi 25 \pm 2$	$\phi 70 \pm 2$	$\phi 9^{+3}_0$ mm	$\phi 29^{+3}_0$ mm
	WCSF 4-3(3#)	$\phi 32 \pm 2$	$\phi 88 \pm 2$	$\phi 11^{+3}_0$ mm	$\phi 41^{+3}_0$ mm
	WCSF 4-4(4#)	$\phi 47 \pm 2$	$\phi 120 \pm 2$	$\phi 16^{+3}_0$ mm	$\phi 46^{+3}_0$ mm
5-core breakout	WCSF 5-1(1#)	$\phi 20 \pm 2$	$\phi 70 \pm 2$	$\phi 7^{+3}_0$ mm	$\phi 27^{+3}_0$ mm
	WCSF 5-2(2#)	$\phi 25 \pm 2$	$\phi 88 \pm 2$	$\phi 9^{+3}_0$ mm	$\phi 37^{+3}_0$ mm
	WCSF 5-3(3#)	$\phi 35 \pm 2$	$\phi 110 \pm 3$	$\phi 12^{+3}_0$ mm	$\phi 48^{+3}_0$ mm
	WCSF 5-4(4#)	$\phi 40 \pm 2$	$\phi 120 \pm 3$	$\phi 13^{+3}_0$ mm	$\phi 49^{+3}_0$ mm
6-core breakout	WCSF 6-1(1#)	$\phi 32 \pm 2$	$\phi 104 \pm 3$	$\phi 10^{+3}_0$ mm	$\phi 39^{+3}_0$ mm
	WCSF 6S-0(1#)	Finger 1 $\phi 28 \pm 2$ Finger 2 $\phi 35 \pm 2$	$\phi 104 \pm 3$	$\phi 10^{+3}_0$ mm	$\phi 39^{+3}_0$ mm

Spec.		ID before shrunk/mm		ID after shrunk/mm	
		Finger ϕ F	Body ϕ C	Finger ϕ F	Body ϕ C
6-core breakout	WCSF 6S-1(1#)	Finger 1 ϕ 14 \pm 2	ϕ 80 \pm 2	ϕ 5 $^{+3}_0$ mm	ϕ 27 $^{+3}_0$ mm
		Finger 2 ϕ 25 \pm 2		ϕ 9 $^{+3}_0$ mm	
	WCSF 6S-2(2#)	Finger 1 ϕ 20 \pm 2	ϕ 104 \pm 3	ϕ 7 $^{+3}_0$ mm	ϕ 37 $^{+3}_0$ mm
		Finger 2 ϕ 32 \pm 2		ϕ 12 $^{+3}_0$ mm	
	WCSF 6S-3(3#)	Finger 1 ϕ 25 \pm 2	ϕ 120 \pm 3	ϕ 9 $^{+3}_0$ mm	ϕ 49 $^{+3}_0$ mm
		Finger 2 ϕ 40 \pm 2		ϕ 17 $^{+3}_0$ mm	
	WCSF 6S-4(4#)	Finger 1 ϕ 28 \pm 2	ϕ 140 \pm 2	ϕ 12 $^{+3}_0$ mm	ϕ 61 $^{+3}_0$ mm
		Finger 2 ϕ 47 \pm 2		ϕ 21 $^{+3}_0$ mm	

Remark: 1. 6-core breakouts (with 3 big fingers and 3 small fingers) are used on trailing cable, variable frequency cables, telecommunication cables, control cables, etc.
 2. Special specification is available per different requirements.

WCSEC Cold Shrink End Cap



- Manufactured from EPDM rubber .
- Meeting a variety of configuration requirements.
- Providing sealing protection over multi-core cable ends.
- Simple and fast installation, no tools required.
- Sealing tight, high rebound even after prolonged years of aging and exposure.
- No mastic or tape required.
- High resistance to fungus, acid, alkalis and ozone.
- No training required for installation.

Selection Table

Product No.	ID as Supplied(\pm 2) /mm	ID after Fully Recovered (Max)/mm	Application Range/mm	Length after Fully Recovered(\pm 5)/mm
WCSEC-1	ϕ 20	ϕ 12	ϕ 13- ϕ 15	100
WCSEC-2	ϕ 28	ϕ 16	ϕ 18- ϕ 23	100
WCSEC-3	ϕ 47/ ϕ 56	ϕ 23	ϕ 25- ϕ 38/ ϕ 25- ϕ 48	100
WCSEC-4	ϕ 80	ϕ 46	ϕ 48- ϕ 70	100

WSKG

Silicone Rubber Overhead Line Cover



The silicone rubber overhead line cover is our patented product. It is made of silicone rubber which is highly resistant to aging, erosion and corona. It can provide protection against electrical outages caused by incidental contact from tree branches or wildlife.



- Made of silicone rubber.
- High resistance to aging and erosion.
- Providing insulation for catenaries, droppers and conductors against contact from trees or wildlife.
- Simple and fast installation, widely used in emergency repairs or temporary insulation protection of equipment.

Selection Table

Product Size/mm	Φ12	Φ15.6	Φ17	Φ20	Φ24.2	Φ30	Φ32	Φ35	Φ39.8
Conductor Diameter/mm	7~10	10~13	13~15	15~18	18~23	23~28	28~30	30~33	33~37

Spec.	ID(mm)	Wall Thickness(mm) and Voltage Rating				
		≤10kV	10kV~27.5kV	27.5kV~35kV	35kV~110kV	110kV~220kV
Φ12.0	Φ12.0±1.0	2.3±0.3				
Φ15.6	Φ15.6±1.0					
Φ17.0	Φ17.0±1.0					
Φ20.0	Φ20.0±1.0					
Φ24.2	Φ24.2±1.0		3.0±0.4	3.0±0.4	4.0±0.5	6.0±1.0
Φ30.0	Φ30.0±1.0					
Φ32.0	Φ32.0±1.0					
Φ35.0	Φ35.0±1.0					
Φ39.8	Φ39.8±1.0					

WRKG

Overhead Line Cover



Description

The overhead line cover is a cold-applied wraparound cover that provides insulation protection for overhead bare conductors and busbar. It can help prevent electrical outages caused by incidental contact from tree branches or wildlife.

Feature

- Made of cross linked polyolefin .
- Simple and fast wraparound installation.
- Built-in creepage fitting with longer creepage distance and better performance.
- High resistance to aging and erosion.
- Superior UV and abrasion resistance.
- New product sealed with adhesive is available for 25kV.
- Voltage class: 15 kV, 25 kV.

Selection Table

Product No.	Spec.	Conductor Cross Section/mm ²	Max Conductor Diameter/mm	Thickness/mm (D)	Length/mm (L)
-------------	-------	---	---------------------------	------------------	---------------

Voltage class: Up to 20kV

WRKG-1	Φ14	up to 70	14	1.8±0.2	53±2
WRKG-2	Φ18	95/120/150	18	2.2±0.2	68±2
WRKG-3	Φ23	185/240	24	2.3±0.2	74±3
WRKG-4	Φ31	300	28	2.3±0.2	85±3
WRKG-5	Φ38	400-800	38	2.4±0.2	115±3

Voltage class: 25kV **and Above** (Sealed with adhesive)

WRKG-2*	Φ18	up to 150	18	2.2±0.2	68±2
WRKG-3*	Φ23	185-240	24	2.3±0.2	74±3
WRKG-4*	Φ31	300	28	2.3±0.2	85±3
WRKG-5*	Φ38	400-800	38	2.4±0.2	115±3

Technical Data

Property	Test Method	Standard Value
Tensile Strength	ASTM-D-638	≥8MPa
Elongation at Break	ASTM-D-638	≥300%
Volume Resistivity	IEC 60093	≥1x10 ¹⁴ Ω · cm
Dielectric Strength	IEC 60243	≥25kV/mm

WBH

Silicone Rubber Protective Cover



WBH-BY1



WBH-BY5



WBH-BL2



WBH-BL2



WBH-JL2



WBH-DL2



WBH-DL5



WBH-DL7



WBH-XJ



WBH-NJ



WBH-BG



WBH-XJ

- Manufactured from silicone rubber.
- Used to provide environmental protection for various electrical connections.
- Offering tailor-made solutions against specific requirements.

Selection Table

Part No.	Description	Color
WBH-BY1	Protective Covers for Inlets and Outlets	Red, Green, Yellow, Black
WBH-BY5	Protective Covers for Inlets and Outlets	Red, Green, Yellow, Black
WBH-BL2	Protective Covers for Inlets and Outlets	Red, Green, Yellow, Black
WBH-JL2	Protective Covers for Inlets and Outlets	Red, Green, Yellow, Black
WBH-DL2	Protective Covers for Outdoor Drop-off Fuser	Red, Green, Yellow, Black
WBH-DL5	Protective Covers for Outdoor Drop-off Fuser	Red, Green, Yellow, Black
WBH-DL7	Protective Covers for Outdoor Drop-off Fuser	Red, Green, Yellow, Black
WBH-DL9	Protective Covers for Outdoor Drop-off Fuser	Red, Green, Yellow, Black
WBH-XJ	Protective Covers for Overhead Wedge Clamp	Red, Green, Yellow, Black
WBH-NJ	Protective Cover for Tension Clamp	Red, Green, Yellow, Black
WBH-BG	Protective Cover for Parallel Groove Clamp	Red, Green, Yellow, Black
WBH-XJ2	Protective Cover for Suspension Clamp	Red, Green, Yellow, Gray

Feel free to contact us if you need more detailed information.

WRSJB Busbar Cover



- Manufactured from cross linked polyolefin .
- Widely used to protect complex busbar connections where tube products cannot be applied .
- Offering tailor-made solutions against specific requirements.
- Color : red, yellow, green, black.

Selection Table

No. (A×B)	I Type			T Type			L Type		
	L	W	H	L	W	H	L	W	H
30×8	95	35	50	105	35	60	70	35	60
40×8	125	45	50	140	45	60	75	45	55
50×8	135	55	55	155	55	65	90	55	65
60×8	165	65	75	165	65	75	100	65	75
80×10	185	85	75	195	85	75	130	85	75
100×10	220	105	75	215	105	75	140	105	75
120×10	235	125	75	245	125	75	165	125	75
150×10	260	155	75	285	155	75	195	155	75

Remark:

L=length of cover; W=width of cover; H=height of cover

A=width of busbar; B=thickness of busbar

(All dimensions are in mm)

*According to customer drawings the special products for a variety of inlet and outlet of transformers, fuses, switches, surge arresters and other protective cover are available.

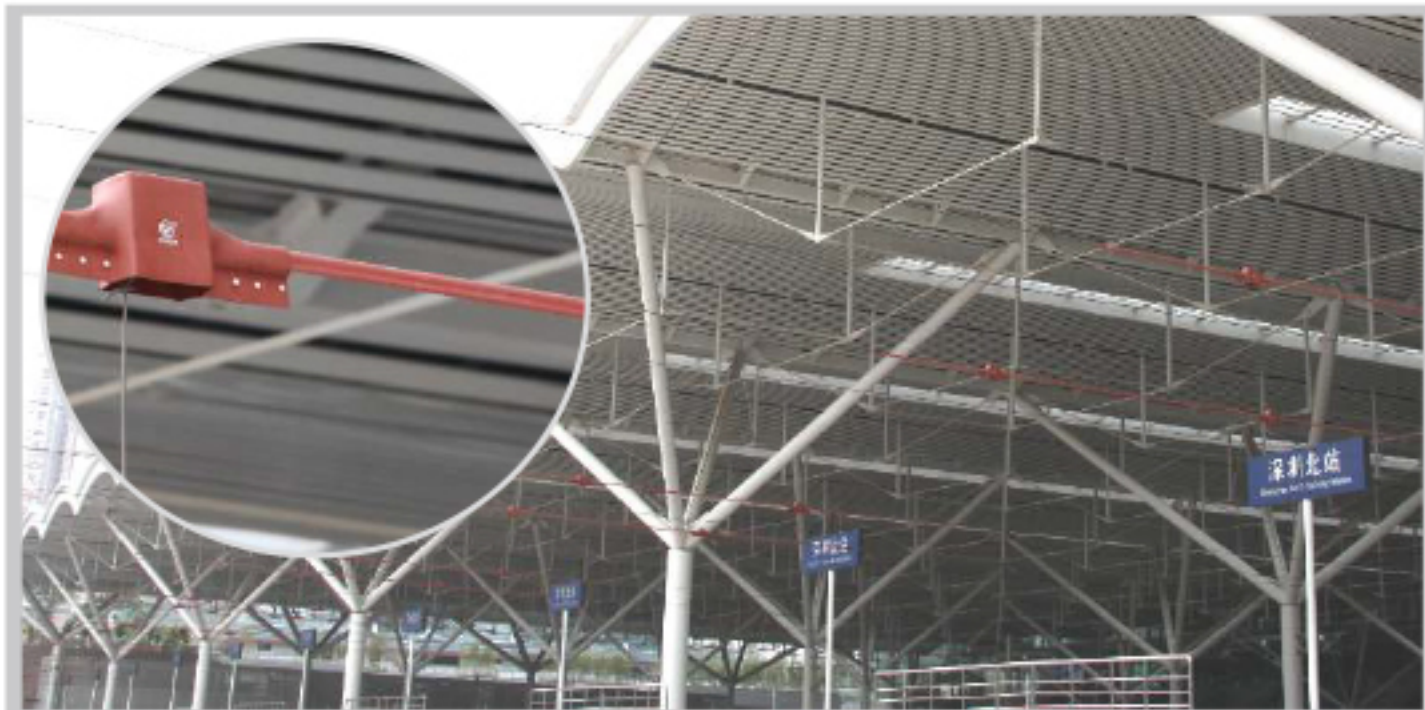

WEYB

Roll-on Sealing Tube



- Easy, “roll-on” way to insulate and seal cable connections up to 1kV.
- Made of EPDM rubber, resisting damage from exposure to moisture, ozone, fungus and temperature extremes from -60°C to 150°C.
- Dual-wall design with an entrapped lubricant, making installation fast and simple.
- Rolls on the cable with minimal effort, even at temperature below -25°C.
- Ideal for use where heating is not allowed.
- Reusable.

Selection Table

Product No.	Tube length ±5/mm	Application range Cable outer diameter /mm
WEYB-14	160	12~20
WEYB-25	370	26~38

Technical Data

Property	Test Method	Standard Value
Ultimate Tensile	ISO 37	≥8.1MPa
Ultimate Elongation	ISO 34	≥750%
Ultimate Tensile after 136°Cx168h	ISO 37	9.5MPa
Ultimate Elongation after 136°Cx168h	ISO 34	719.89
Water Absorption	ISO 62	0.3%
Dielectric Strength	IEC 60243	8kV/mm
Volume Resistivity	ASTM-D-2303	1.3x10 ¹⁵
Environmental Testing	RoHS	Meet the RoHS
Salt Spray Test	GB2423	No crack with ultimate elongation 770% certified by SGS.
Ozone Test	GB7762	No crack certified by SGS.
Low Temperature Ultimate Elongation	-60°Cx4h	391.4%

WESRT

Electronic Silicone Rubber Tube

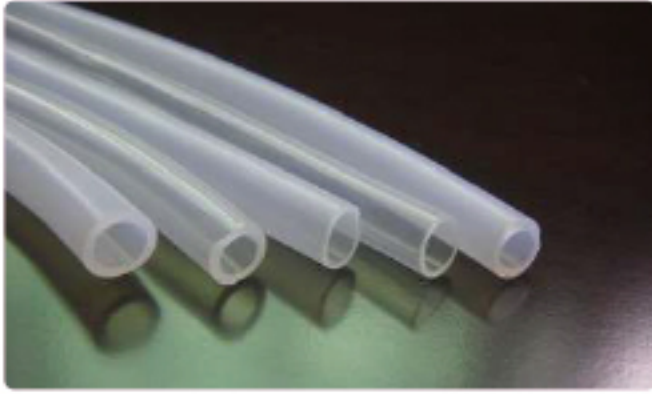

Description

Highly transparent silicone rubber tube is made of good quality silicone rubber through scientific formula and advanced process.

Woeer transparent silicone rubber tube demonstrates good performance of flexibility, high temperature resistance and stable properties.

Widely used in high temperature insulation, corona resistance treatment. Especially applicable in high temperature fluid delivery line, such as water dispenser or coffee machine.

Feature

- Service temperature: -60°C-200°C.
- Flexible, high temperature resistance and corona resistance.
- Conform to RoHS.
- Standard color: transparent, red, blue, white, grey and green.

Selection Table

Product No.	ID (mm)	W.T.&Dielectric Voltage(mm)			
		≥2500V	≥4000V	≥6000V	≥7000V
Φ0.8	0.8±0.10	0.50±0.10	1.00±0.15	1.50±0.20	2.00±0.25
Φ1.0	1.0±0.10	0.50±0.10	1.00±0.15	1.50±0.20	2.00±0.25
Φ1.5	1.5±0.10	0.50±0.10	1.00±0.15	1.50±0.20	2.00±0.25
Φ2.0	2.0±0.10	0.50±0.10	1.00±0.15	1.50±0.20	2.00±0.25
Φ2.5	2.5±0.10	0.50±0.10	1.00±0.15	1.50±0.20	2.00±0.25
Φ3.0	3.0±0.10	0.50±0.10	1.00±0.15	1.50±0.20	2.00±0.25
Φ3.5	3.5±0.10	0.50±0.10	1.00±0.15	1.50±0.20	2.00±0.25
Φ4.0	4.0±0.10	0.50±0.10	1.00±0.15	1.50±0.20	2.00±0.25
Φ4.5	4.5±0.10	0.50±0.10	1.00±0.15	1.50±0.20	2.00±0.25
Φ5.0	5.0±0.20	0.50±0.10	1.00±0.15	1.50±0.20	2.00±0.25
Φ5.5	5.5±0.20	0.50±0.10	1.00±0.15	1.50±0.20	2.00±0.25
Φ6.0	6.0±0.20	0.50±0.10	1.00±0.15	1.50±0.20	2.00±0.25
Φ6.5	6.5±0.20	0.50±0.10	1.00±0.15	1.50±0.20	2.00±0.25
Φ7.0	7.0±0.20	-	1.00±0.15	1.50±0.20	2.00±0.25
Φ7.5	7.5±0.20	-	1.00±0.15	1.50±0.20	2.00±0.25
Φ8.0	8.0±0.25	-	1.00±0.15	1.50±0.20	2.00±0.25
Φ9.0	9.0±0.25	-	1.00±0.15	1.50±0.20	2.00±0.25

Size	ID(mm)	W.T.&Dielectric Voltage(mm)			
		≥2500V	≥4000V	≥6000V	≥7000V
Φ10.0	10.0±0.25	-	1.00±0.15	1.50±0.20	2.00±0.25
Φ11.0	11.0±0.30	-	1.00±0.15	1.50±0.20	2.00±0.25
Φ12.0	12.0±0.30	-	1.00±0.15	1.50±0.20	2.00±0.25
Φ13.0	13.0±0.30	-	1.00±0.15	1.50±0.20	2.00±0.25
Φ14.0	14.0±0.30	-	-	1.50±0.20	2.00±0.25
Φ15.0	15.0±0.30	-	-	1.50±0.20	2.00±0.25
Φ18.0	18.0±0.30	-	-	-	2.00±0.25
Φ20.0	20.0±0.30	-	-	-	2.00±0.25

Remark:Other sizes are available for customizing upon request.

Technical Data

Property	Standard	Test Method
Tensile Strength(MPa)	≥3.5	ASTM D2671
Elongation Rate at Break (%)	≥210	ASTM D2671
Tear Strength(kN/m)	≥22	ASTM D624
Volume Resistivity(Ω · cm)	≥1×10 ¹⁴	IEC 60093
Dielectric Strength(kV/mm)	≥18	IEC 60243
Flammability	VW-1	UL 224

Application

Mainly applicable to coffee machine, water dispenser, iron, rice cooker, fryer, disinfection cabinet, bread machine, fruit pulp machine, water heater and other household appliances.

