

01

Busbar Series

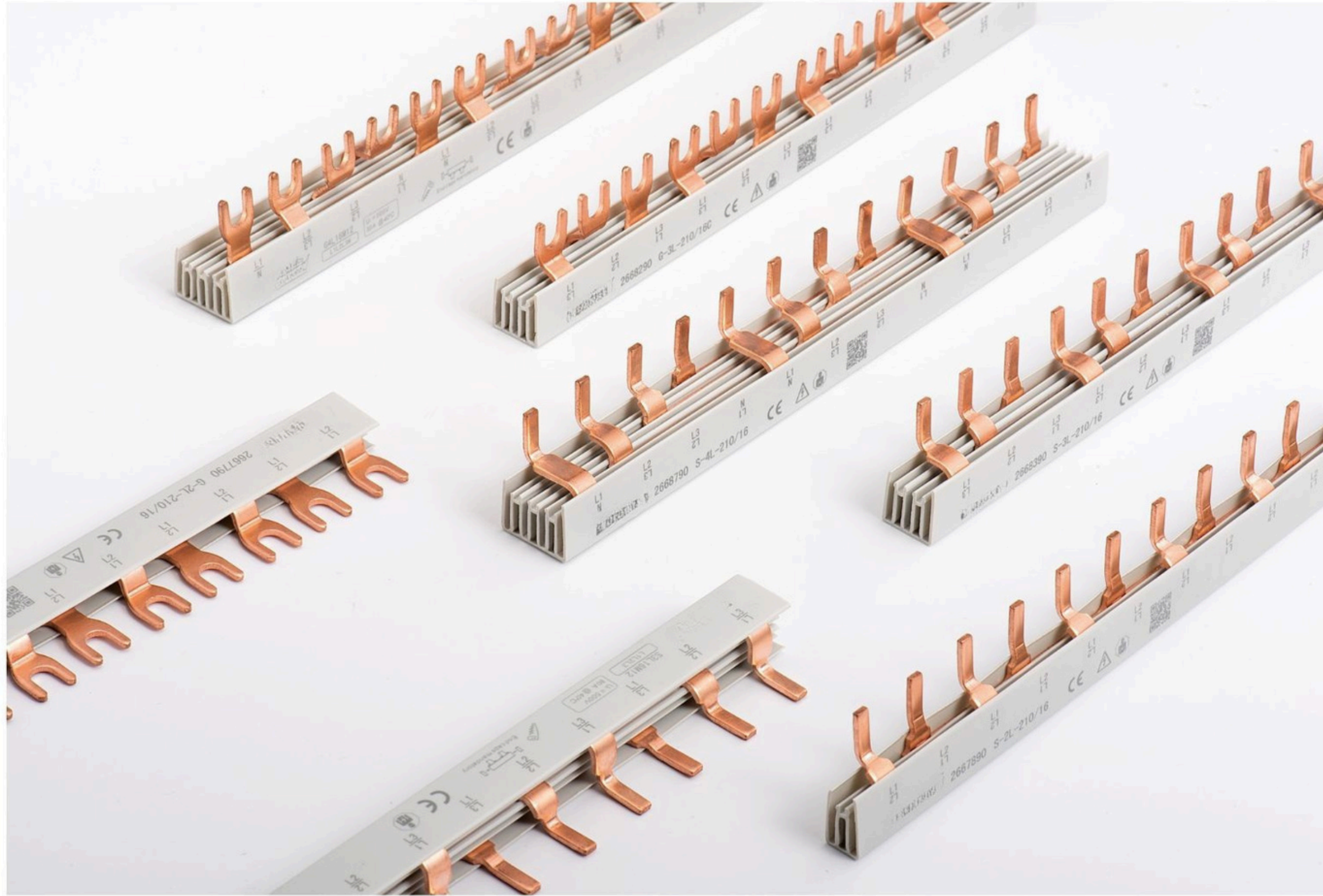

Fork type, 1-phase busbars (M6)



Description	Article No.	A Cross Section	B Distance (mm)	C Width of Fork(mm)	D Length of Fork(mm)	E Modules	F Length (mm)	G Reference Current
F-1L-210/8	KF011208	8mm ²	17.8	12	12	12	210	50A
F-1L-210/10	KF011210	10mm ²	17.8	12	12	12	210	63A
F-1L-210/13	KF011213	13mm ²	17.8	12	12	12	210	70A
F-1L-210/16	KF011216	16mm ²	17.8	12	12	12	210	80A
F-1L-1000/8	KF015408	8mm ²	17.8	12	12	54	1000	50A
F-1L-1000/10	KF015410	10mm ²	17.8	12	12	54	1000	63A
F-1L-1000/13	KF015413	13mm ²	17.8	12	12	54	1000	70A
F-1L-1000/16	KF015416	16mm ²	17.8	12	12	54	1000	80A
F-1L-1016/8	KF015708	8mm ²	17.8	12	12	57	1016	50A
F-1L-1016/10	KF015710	10mm ²	17.8	12	12	57	1016	63A
F-1L-1016/13	KF015713	13mm ²	17.8	12	12	57	1016	70A
F-1L-1016/16	KF015716	16mm ²	17.8	12	12	57	1016	80A
F-1L-1000/25	KF015425	25mm ²	17.8	12	12	54	1000	100A

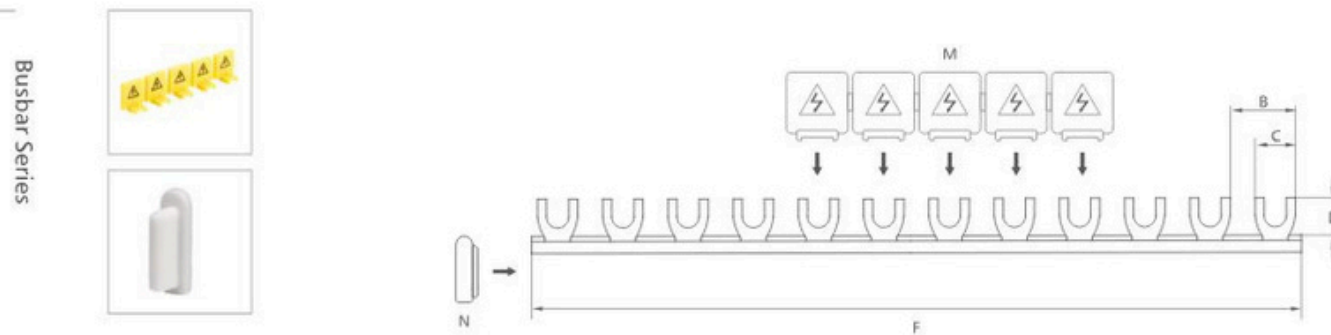

Fork type, 2-phase busbars (M6)

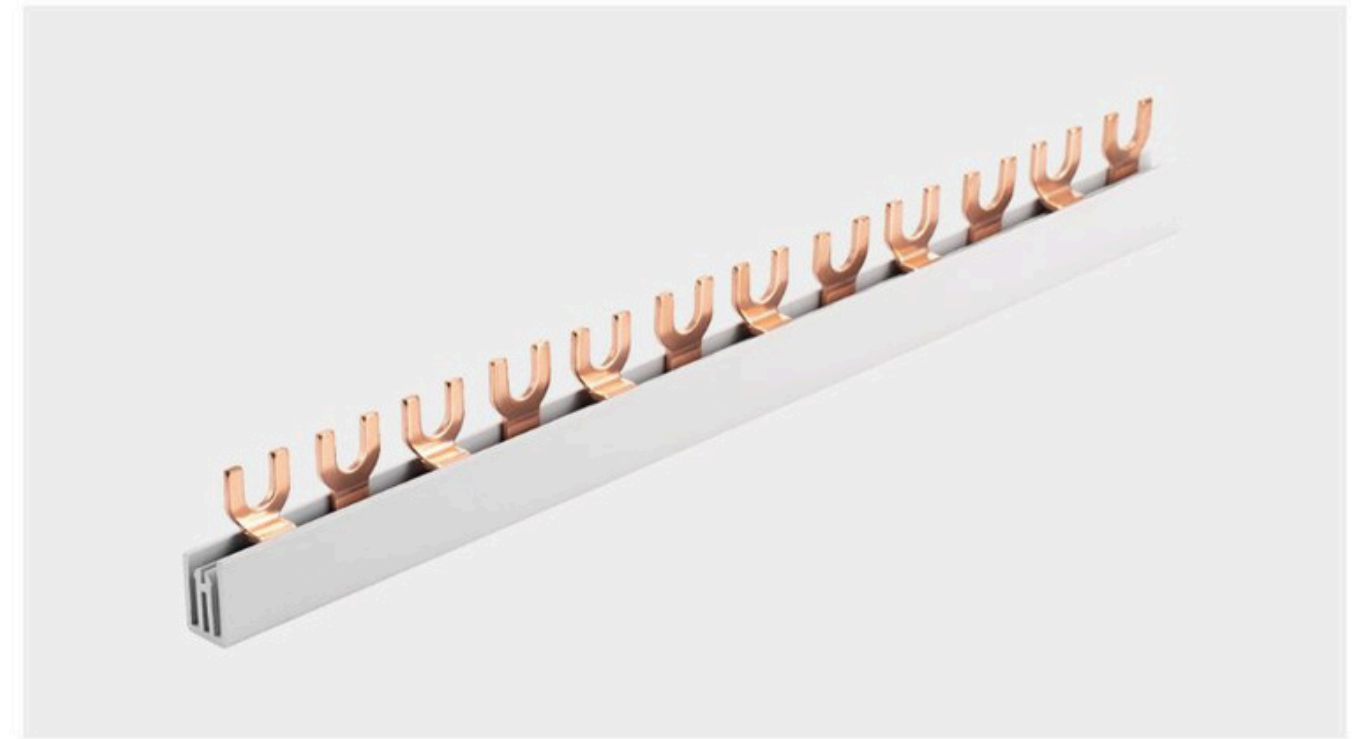

Description	Article No.	A Cross Section	B Distance (mm)	C Width of Fork(mm)	D Length of Fork(mm)	E Modules	F Length (mm)	G Reference Current
F-2L-210/8	KF021208	8mm ²	17.8	12	12	12	210	50A
F-2L-210/10	KF021210	10mm ²	17.8	12	12	12	210	63A
F-2L-210/13	KF021213	13mm ²	17.8	12	12	12	210	70A
F-2L-210/16	KF021216	16mm ²	17.8	12	12	12	210	80A
F-2L-1000/8	KF025408	8mm ²	17.8	12	12	54	1000	50A
F-2L-1000/10	KF025410	10mm ²	17.8	12	12	54	1000	63A
F-2L-1000/13	KF025413	13mm ²	17.8	12	12	54	1000	70A
F-2L-1000/16	KF025416	16mm ²	17.8	12	12	54	1000	80A
F-2L-1016/8	KF025608	8mm ²	17.8	12	12	56	1016	50A
F-2L-1016/10	KF025610	10mm ²	17.8	12	12	56	1016	63A
F-2L-1016/13	KF025613	13mm ²	17.8	12	12	56	1016	70A
F-2L-1016/16	KF025616	16mm ²	17.8	12	12	56	1016	80A
F-2L-1000/25	KF025425	25mm ²	17.8	12	12	54	1000	100A

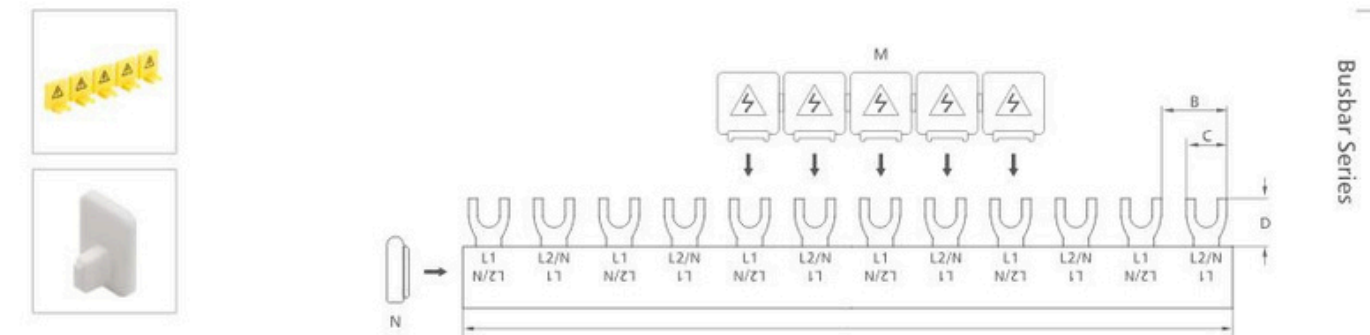

Fork type, 3-phase busbars (M6)

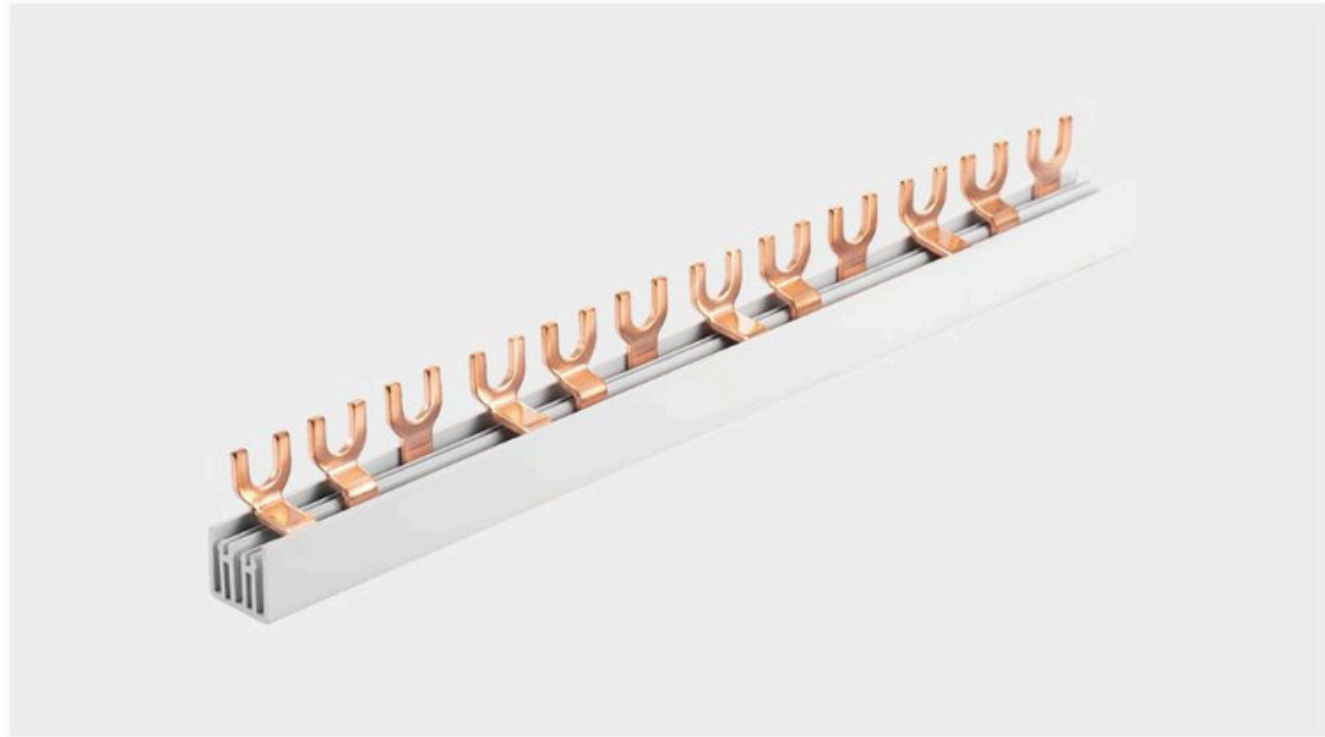

Description	Article No.	A Cross Section	B Distance (mm)	C Width of Fork (mm)	D Length of Fork (mm)	E Modules	F Length (mm)	G Reference Current
F-3L-210/8	KF031208	8mm ²	17.8	12	12	12	210	50A
F-3L-210/10	KF031210	10mm ²	17.8	12	12	12	210	63A
F-3L-210/13	KF031213	13mm ²	17.8	12	12	12	210	70A
F-3L-210/16	KF031216	16mm ²	17.8	12	12	12	210	80A
F-3L-1000/8	KF035408	8mm ²	17.8	12	12	54	1000	50A
F-3L-1000/10	KF035410	10mm ²	17.8	12	12	54	1000	63A
F-3L-1000/13	KF035413	13mm ²	17.8	12	12	54	1000	70A
F-3L-1000/16	KF035416	16mm ²	17.8	12	12	54	1000	80A
F-3L-1016/8	KF035708	8mm ²	17.8	12	12	57	1016	50A
F-3L-1016/10	KF035710	10mm ²	17.8	12	12	57	1016	63A
F-3L-1016/13	KF035713	13mm ²	17.8	12	12	57	1016	70A
F-3L-1016/16	KF035716	16mm ²	17.8	12	12	57	1016	80A
F-3L-1000/25	KF035425	25mm ²	17.8	12	12	54	1000	100A

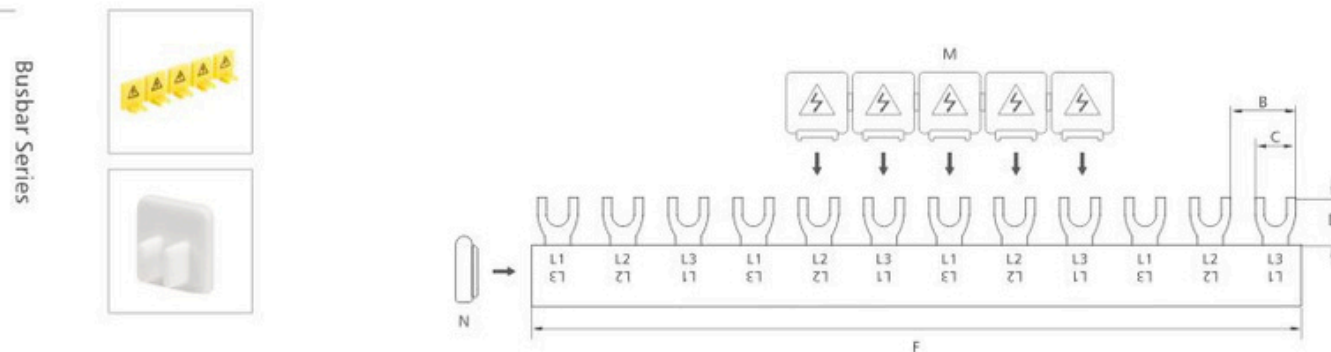

Fork type, 3-phase busbars (M5)

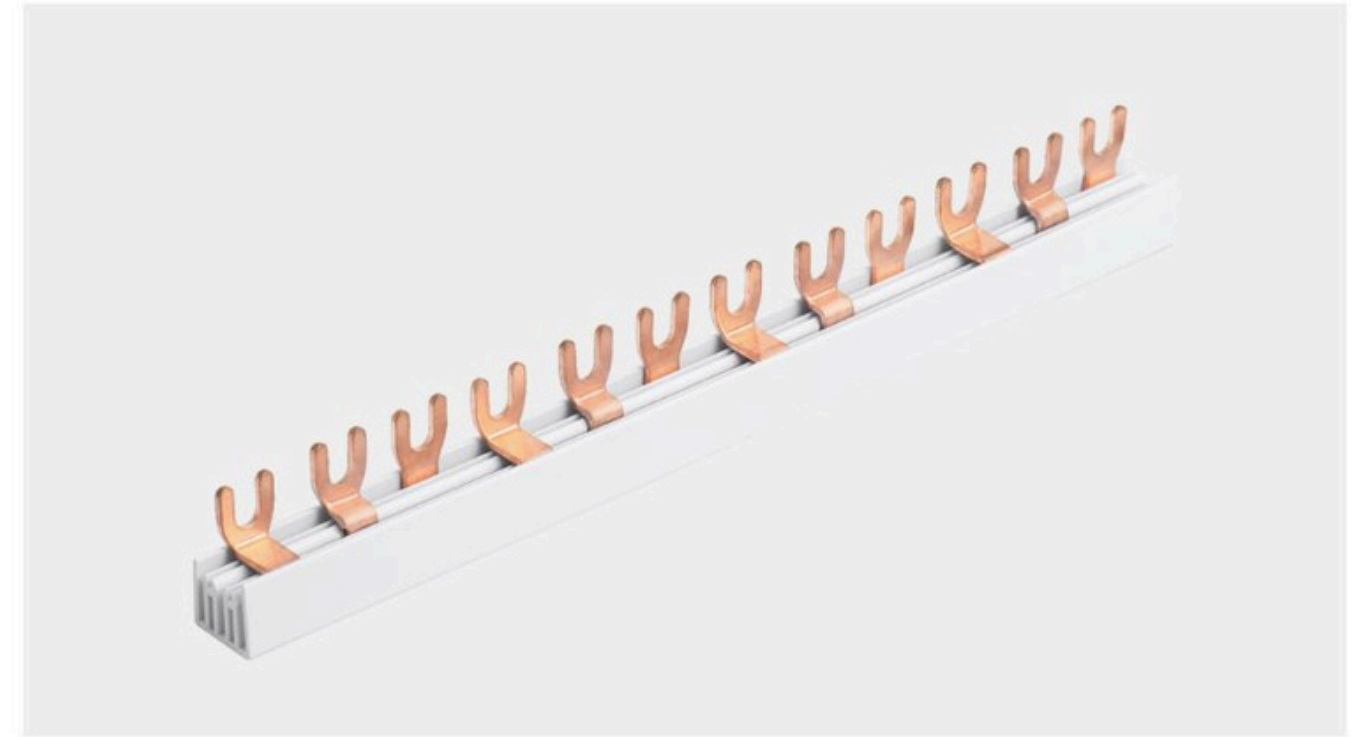

Description	Article No.	A Cross Section	B Distance (mm)	C Width of Fork (mm)	D Length of Fork (mm)	E Modules	F Length (mm)	G Reference Current
F-3L-210/8/M5	KF031208/5	8mm ²	17.8	11	11.5	12	210	50A
F-3L-210/10/M5	KF031210/5	10mm ²	17.8	11	11.5	12	210	63A
F-3L-210/13/M5	KF031213/5	13mm ²	17.8	11	11.5	12	210	70A
F-3L-210/16/M5	KF031216/5	16mm ²	17.8	11	11.5	12	210	80A
F-3L-1000/8/M5	KF035408/5	8mm ²	17.8	11	11.5	54	1000	50A
F-3L-1000/10/M5	KF035410/5	10mm ²	17.8	11	11.5	54	1000	63A
F-3L-1000/13/M5	KF035413/5	13mm ²	17.8	11	11.5	54	1000	70A
F-3L-1000/16/M5	KF035416/5	16mm ²	17.8	11	11.5	54	1000	80A
F-3L-1016/8/M5	KF035708/5	8mm ²	17.8	11	11.5	57	1016	50A
F-3L-1016/10/M5	KF035710/5	10mm ²	17.8	11	11.5	57	1016	63A
F-3L-1016/13/M5	KF035713/5	13mm ²	17.8	11	11.5	57	1016	70A
F-3L-1016/16/M5	KF035716/5	16mm ²	17.8	11	11.5	57	1016	80A

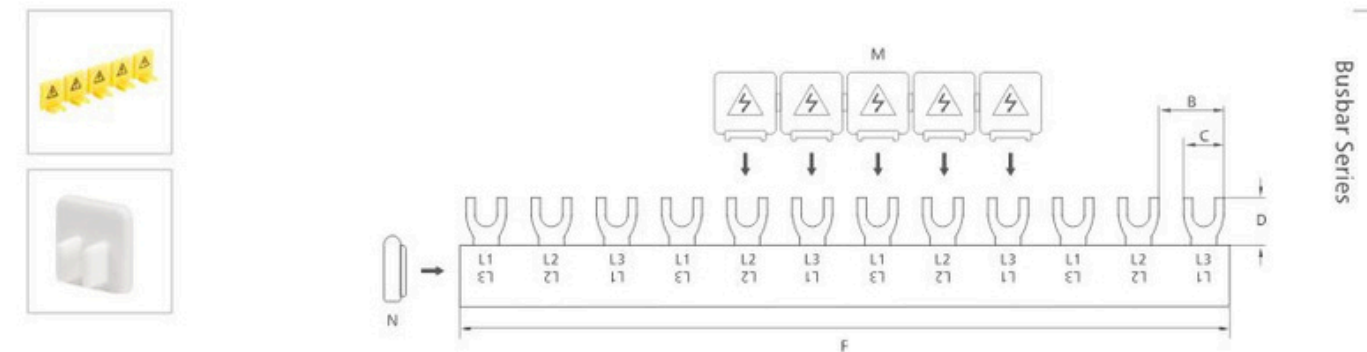

Fork type, 4-phase busbars (M6)

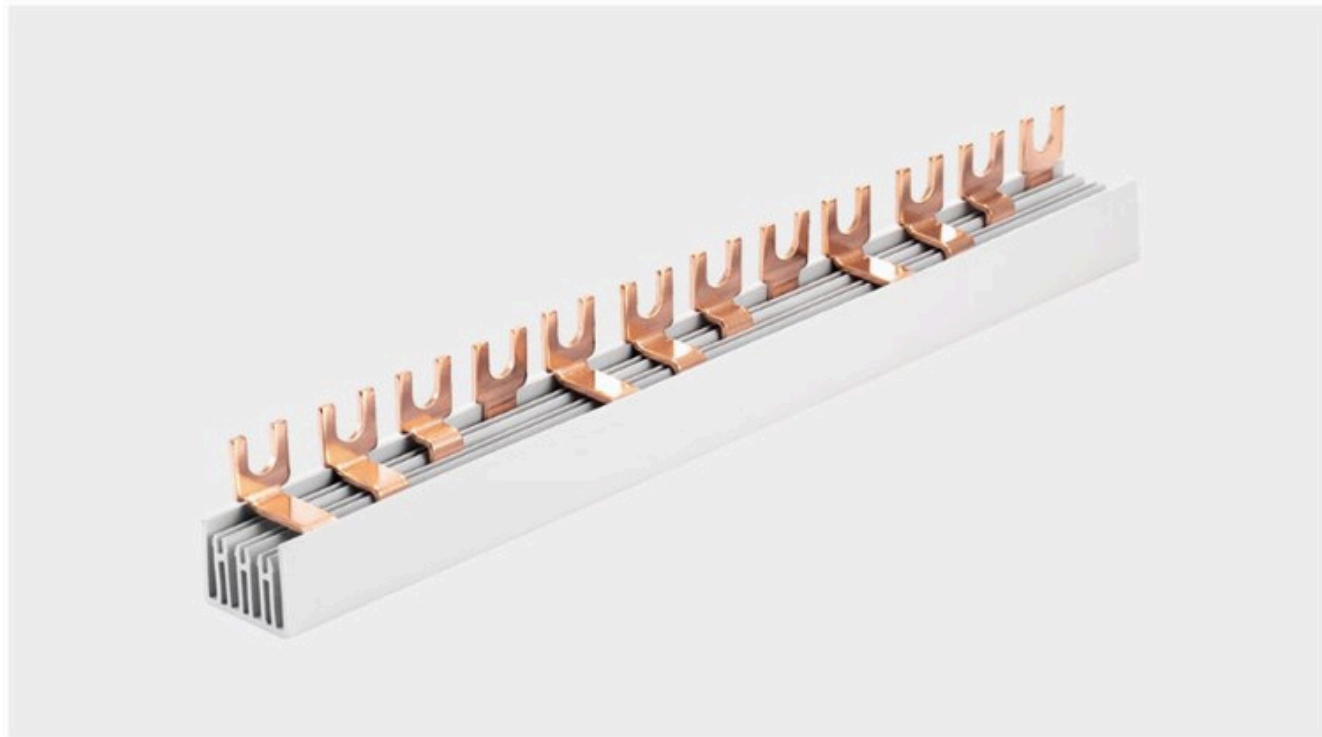

Description	Article No.	A Cross Section	B Distance (mm)	C Width of Fork(mm)	D Length of Fork(mm)	E Modules	F Length (mm)	G Reference Current
F-4L-210/8	KF041208	8mm ²	17.8	12	12	12	210	50A
F-4L-210/10	KF041210	10mm ²	17.8	12	12	12	210	63A
F-4L-210/13	KF041213	13mm ²	17.8	12	12	12	210	70A
F-4L-210/16	KF041216	16mm ²	17.8	12	12	12	210	80A
F-4L-1016/8	KF045608	8mm ²	17.8	12	12	56	1016	50A
F-4L-1016/10	KF045610	10mm ²	17.8	12	12	56	1016	63A
F-4L-1016/13	KF045613	13mm ²	17.8	12	12	56	1016	70A
F-4L-1016/16	KF045616	16mm ²	17.8	12	12	56	1016	80A
F-4L-1000/25	KF045425	25mm ²	17.8	12	12	54	1000	100A

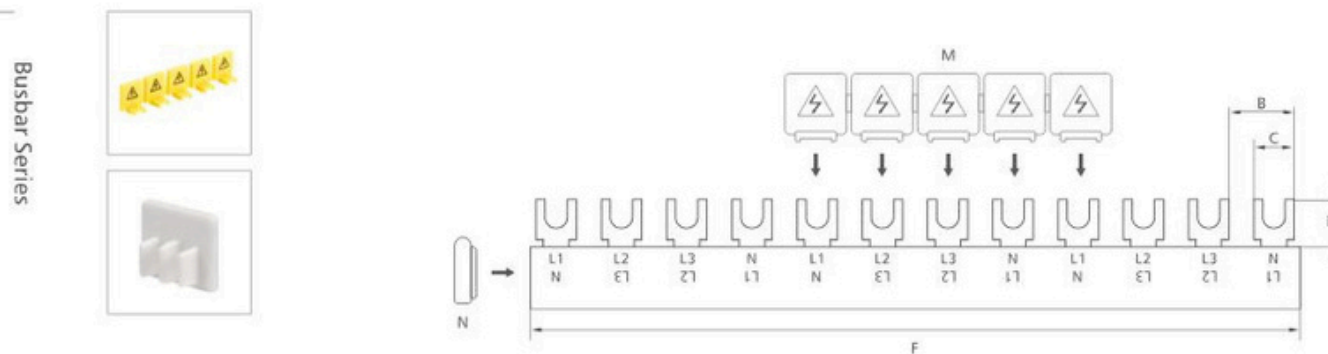

Pin type, 1-phase busbars



Description	Article No.	A Cross Section	B Distance (mm)	C Width of Pin(mm)	D Length of Pin(mm)	E Modules	F Length (mm)	G Reference Current
P-1L-210/8	KP011208	8mm ²	17.8	4	11.5	12	210	50A
P-1L-210/10	KP011210	10mm ²	17.8	4	11.5	12	210	63A
P-1L-210/13	KP011213	13mm ²	17.8	4	11.5	12	210	70A
P-1L-210/16	KP011216	16mm ²	17.8	4	11.5	12	210	80A
P-1L-1000/8	KP015408	8mm ²	17.8	4	11.5	54	1000	50A
P-1L-1000/10	KP015410	10mm ²	17.8	4	11.5	54	1000	63A
P-1L-1000/13	KP015413	13mm ²	17.8	4	11.5	54	1000	70A
P-1L-1000/16	KP015416	16mm ²	17.8	4	11.5	54	1000	80A
P-1L-1016/8	KP015708	8mm ²	17.8	4	11.5	57	1016	50A
P-1L-1016/10	KP015710	10mm ²	17.8	4	11.5	57	1016	63A
P-1L-1016/13	KP015713	13mm ²	17.8	4	11.5	57	1016	70A
P-1L-1016/16	KP015716	16mm ²	17.8	4	11.5	57	1016	80A

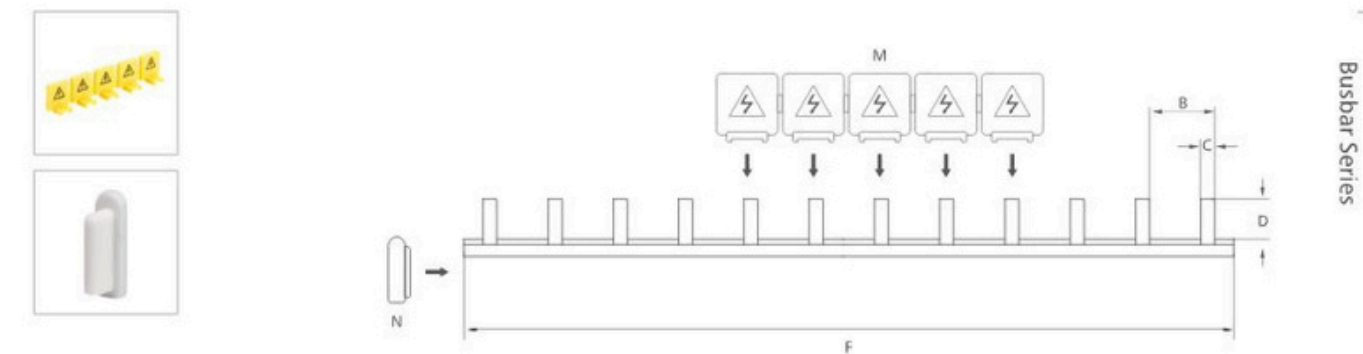

Pin type, 2-phase busbars

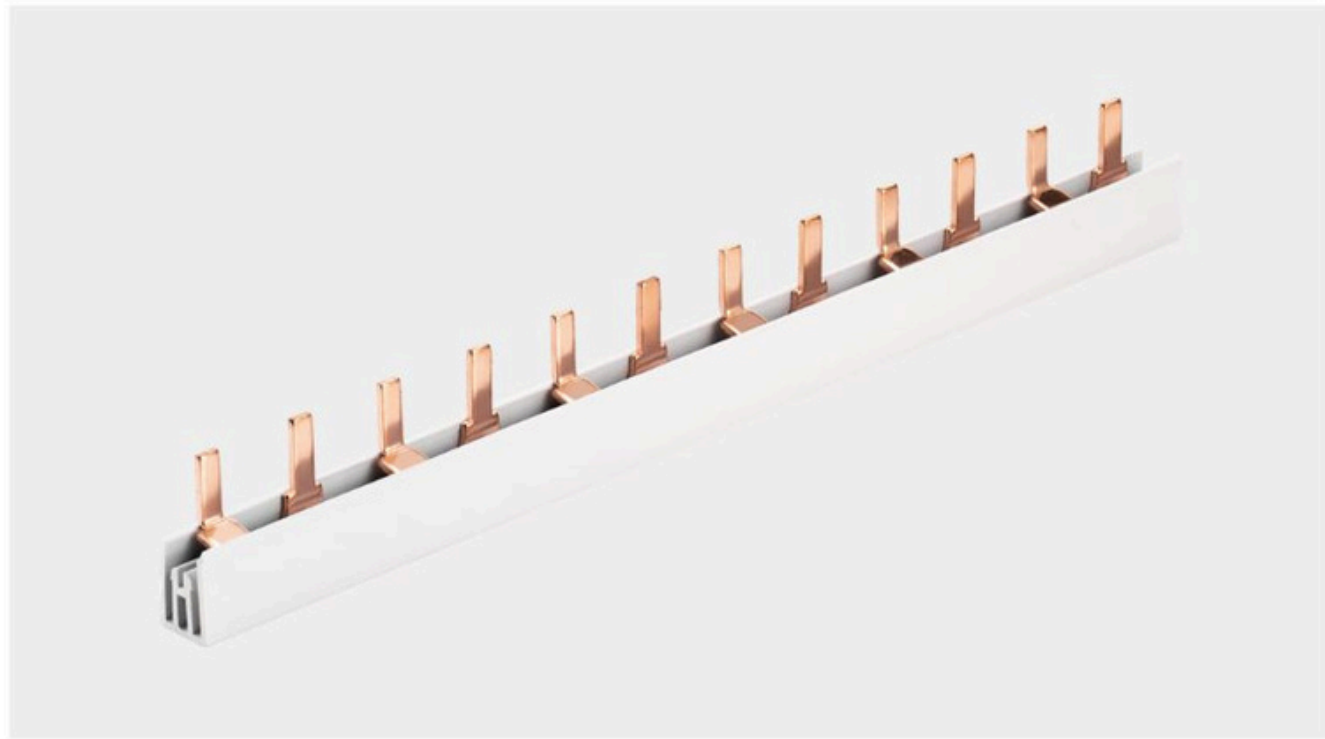

Description	Article No.	A Cross Section	B Distance (mm)	C Width of Pin(mm)	D Length of Pin(mm)	E Modules	F Length (mm)	G Reference Current
P-2L-210/8	KP021208	8mm ²	17.8	4	11.5	12	210	50A
P-2L-210/10	KP021210	10mm ²	17.8	4	11.5	12	210	63A
P-2L-210/13	KP021213	13mm ²	17.8	4	11.5	12	210	70A
P-2L-210/16	KP021216	16mm ²	17.8	4	11.5	12	210	80A
P-2L-1000/8	KP025408	8mm ²	17.8	4	11.5	54	1000	50A
P-2L-1000/10	KP025410	10mm ²	17.8	4	11.5	54	1000	63A
P-2L-1000/13	KP025413	13mm ²	17.8	4	11.5	54	1000	70A
P-2L-1000/16	KP025416	16mm ²	17.8	4	11.5	54	1000	80A
P-2L-1016/8	KP025608	8mm ²	17.8	4	11.5	56	1016	50A
P-2L-1016/10	KP025610	10mm ²	17.8	4	11.5	56	1016	63A
P-2L-1016/13	KP025613	13mm ²	17.8	4	11.5	56	1016	70A
P-2L-1016/16	KP025616	16mm ²	17.8	4	11.5	56	1016	80A

Pin type, 3-phase busbars

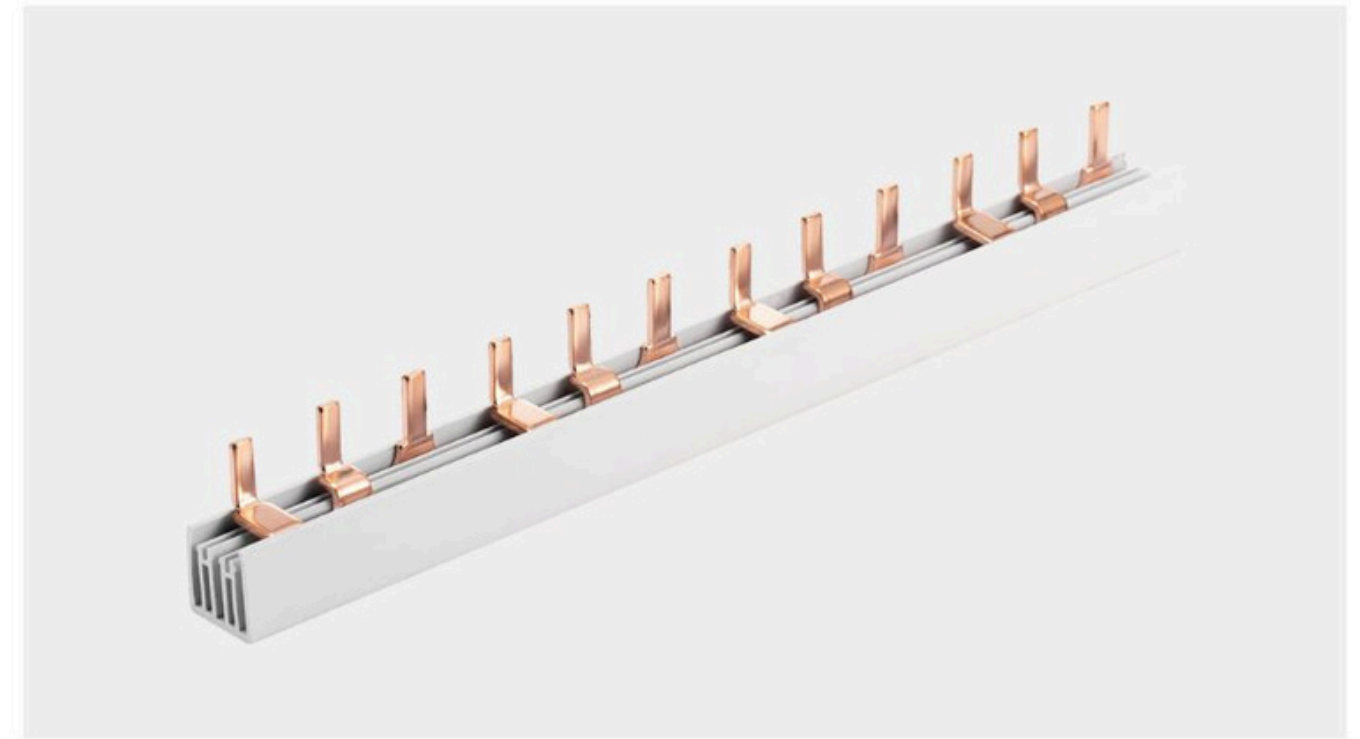

Description	Article No.	A Cross Section	B Distance (mm)	C Width of Pin(mm)	D Length of Pin(mm)	E Modules	F Length (mm)	G Reference Current
P-3L-210/8	KP031208	8mm ²	17.8	4	11.5	12	210	50A
P-3L-210/10	KP031210	10mm ²	17.8	4	11.5	12	210	63A
P-3L-210/13	KP031213	13mm ²	17.8	4	11.5	12	210	70A
P-3L-210/16	KP031216	16mm ²	17.8	4	11.5	12	210	80A
P-3L-1000/8	KP035408	8mm ²	17.8	4	11.5	54	1000	50A
P-3L-1000/10	KP035410	10mm ²	17.8	4	11.5	54	1000	63A
P-3L-1000/13	KP035413	13mm ²	17.8	4	11.5	54	1000	70A
P-3L-1000/16	KP035416	16mm ²	17.8	4	11.5	54	1000	80A
P-3L-1016/8	KP035708	8mm ²	17.8	4	11.5	57	1016	50A
P-3L-1016/10	KP035710	10mm ²	17.8	4	11.5	57	1016	63A
P-3L-1016/13	KP035713	13mm ²	17.8	4	11.5	57	1016	70A
P-3L-1016/16	KP035716	16mm ²	17.8	4	11.5	57	1016	80A

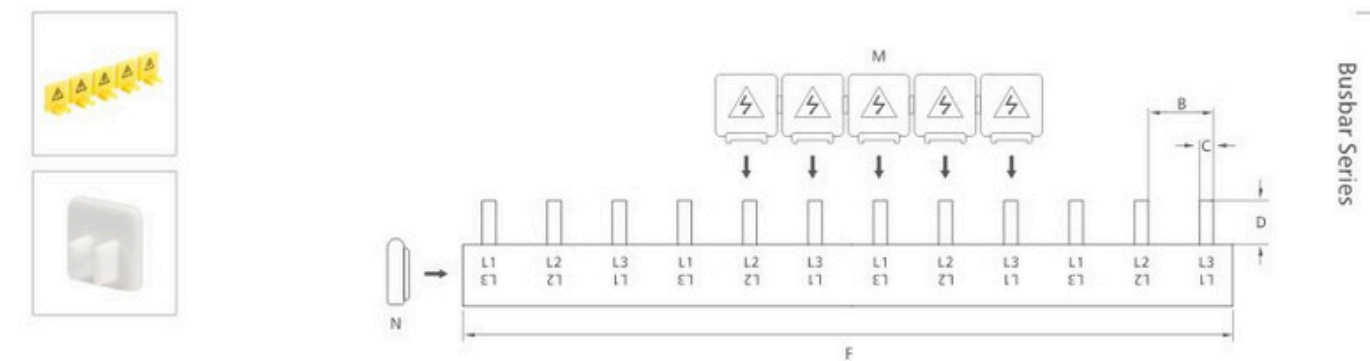
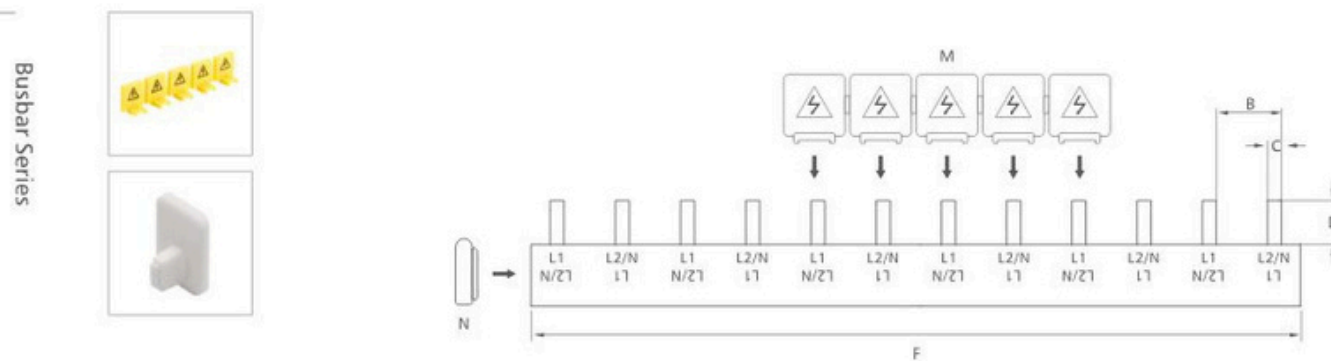

Pin type, 4-phase busbars

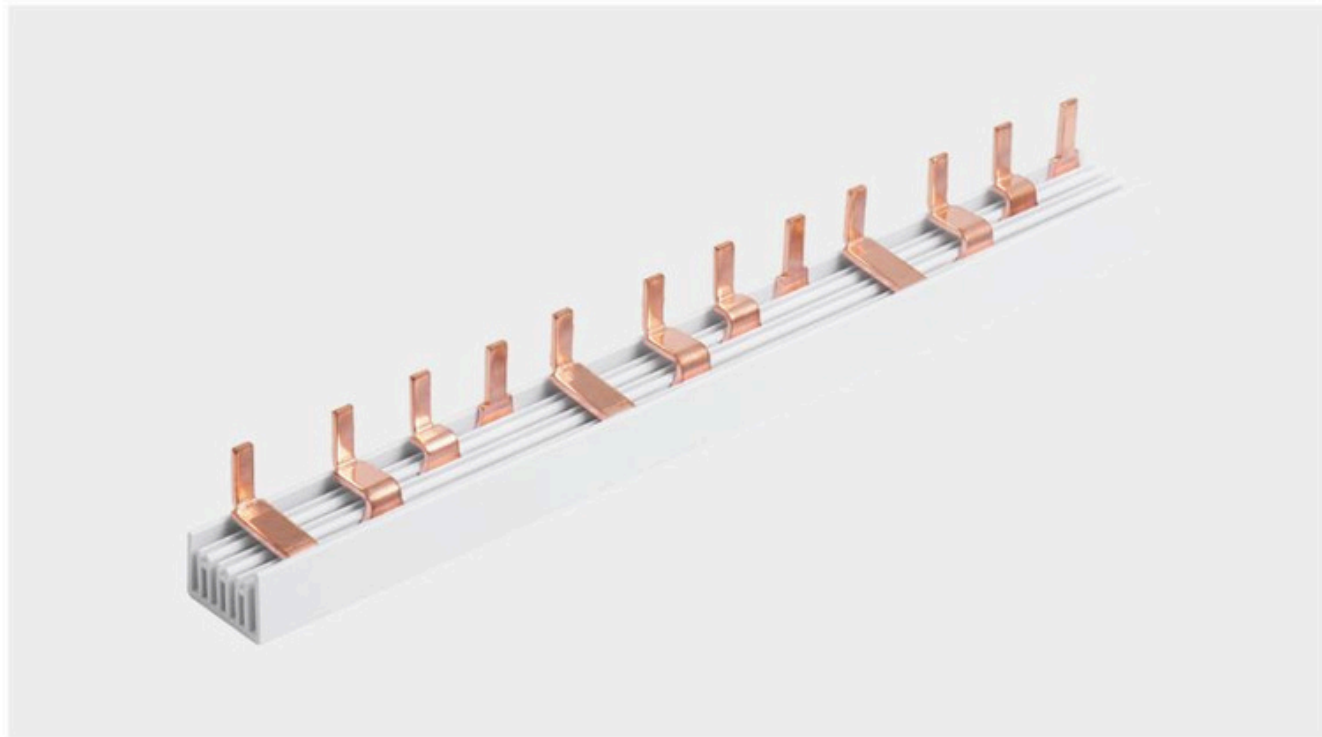

Description	Article No.	A Cross Section	B Distance (mm)	C Width of Pin(mm)	D Length of Pin(mm)	E Modules	F Length (mm)	G Reference Current
P-4L-210/8	KP041208	8mm ²	17.8	4	11.5	12	210	50A
P-4L-210/10	KP041210	10mm ²	17.8	4	11.5	12	210	63A
P-4L-210/13	KP041213	13mm ²	17.8	4	11.5	12	210	70A
P-4L-210/16	KP041216	16mm ²	17.8	4	11.5	12	210	80A
P-4L-1016/8	KP045608	8mm ²	17.8	4	11.5	56	1016	50A
P-4L-1016/10	KP045610	10mm ²	17.8	4	11.5	56	1016	63A
P-4L-1016/13	KP045613	13mm ²	17.8	4	11.5	56	1016	70A
P-4L-1016/16	KP045616	16mm ²	17.8	4	11.5	56	1016	80A

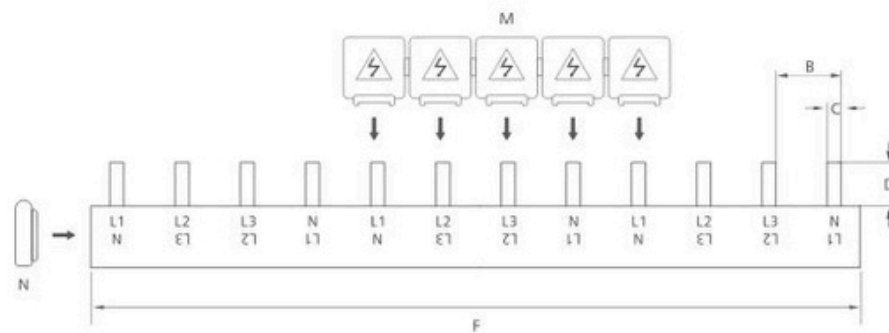
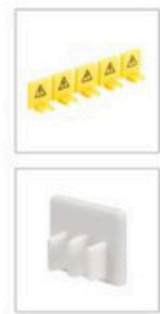

Busbar Series

Pin type, 1P+N busbars

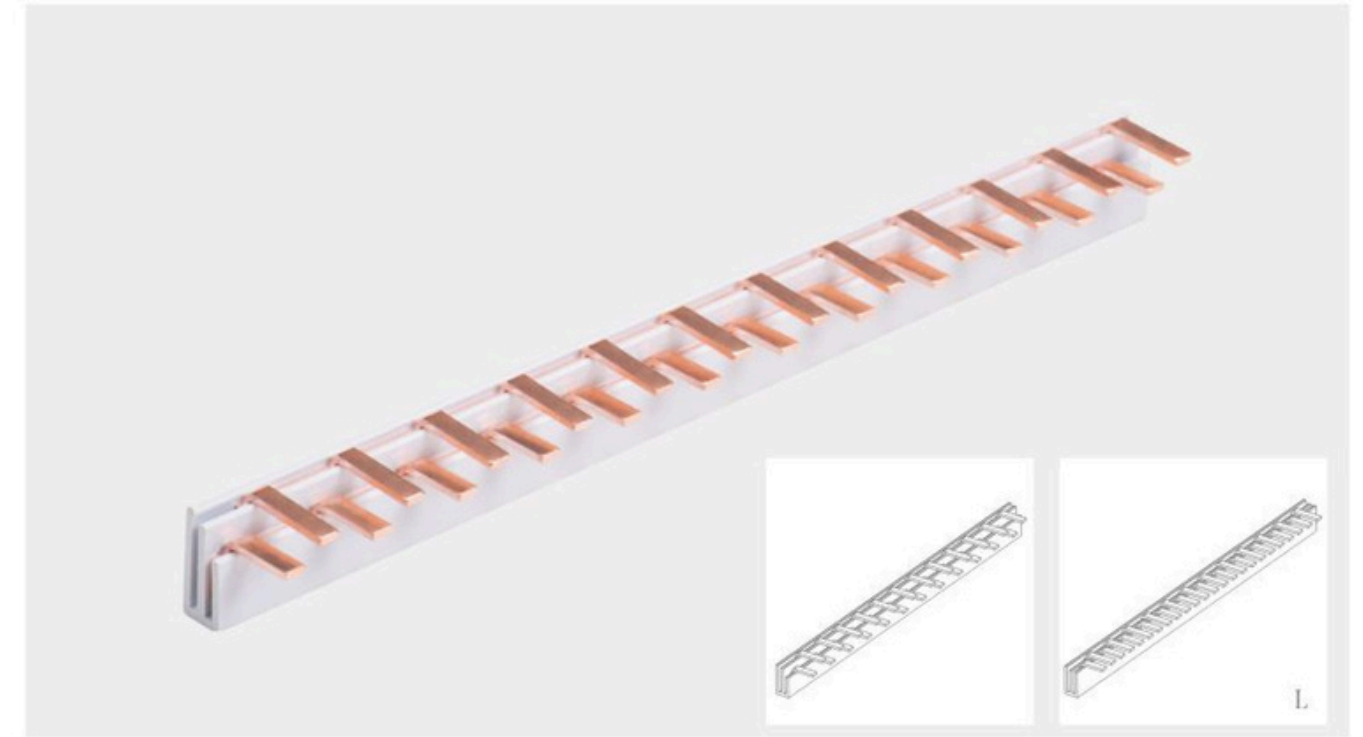

Description	Article No.	A Cross Section	B Distance(mm)	C Width of Pin(mm)	D Length of Pin(mm)	E Modules	F Length (mm)	G Reference Current
P-1+N-210/8(1P)	KP061208	8mm ²	9	4	11.5	24	210	50A
P-1+N-210/10(1P)	KP061210	10mm ²	9	4	11.5	24	210	63A
P-1+N-210/13(1P)	KP061213	13mm ²	9	4	11.5	24	210	70A
P-1+N-210/16(1P)	KP061216	16mm ²	9	4	11.5	24	210	80A
P-1+N-1000/8(1P)	KP065408	8mm ²	9	4	11.5	108	1000	50A
P-1+N-1000/10(1P)	KP065410	10mm ²	9	4	11.5	108	1000	63A
P-1+N-1000/13(1P)	KP065413	10mm ²	9	4	11.5	108	1000	70A
P-1+N-1000/16(1P)	KP065416	16mm ²	9	4	11.5	108	1000	80A
P-1+N-210/8(1P)L	KP061208L	8mm ²	9	4	11.5	24	210	50A
P-1+N-210/10(1P)L	KP061210L	10mm ²	9	4	11.5	24	210	63A
P-1+N-210/13(1P)L	KP061213L	13mm ²	9	4	11.5	24	210	70A
P-1+N-210/16(1P)L	KP061216L	16mm ²	9	4	11.5	24	210	80A
P-1+N-1000/8(1P)L	KP0610808L	8mm ²	9	4	11.5	108	1000	50A
P-1+N-1000/10(1P)L	KP0610810L	10mm ²	9	4	11.5	108	1000	63A
P-1+N-1000/13(1P)L	KP0610813L	10mm ²	9	4	11.5	108	1000	70A
P-1+N-1000/16(1P)L	KP0610816L	16mm ²	9	4	11.5	108	1000	80A

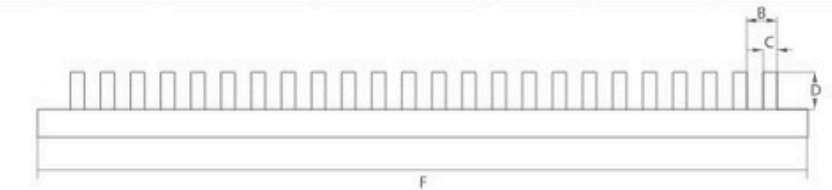

Busbar Series

Pin type, 1P+N busbars

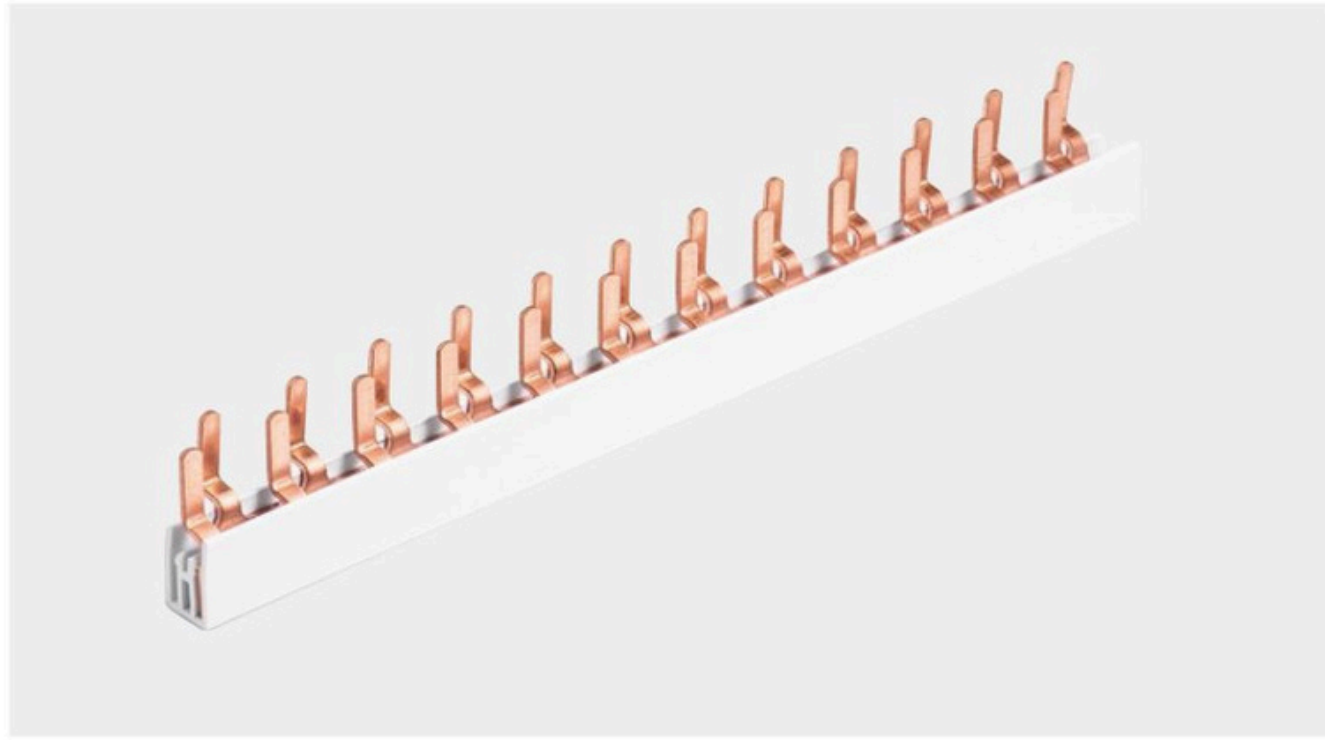

Description	Article No.	A Cross Section	B Distance(mm)	C Width of Pin(mm)	D Length of Pin(mm)	E Modules	F Length (mm)	G Reference Current
P-1+N-210/8V	KP071208V	8mm ²	8.9	4	12	24	210	50A
P-1+N-210/10V	KP071210V	10mm ²	8.9	4	12	24	210	63A
P-1+N-210/13V	KP071213V	13mm ²	8.9	4	12	24	210	70A
P-1+N-210/16V	KP071216V	16mm ²	8.9	4	12	24	210	80A
P-1+N-1000/8V	KP075408V	8mm ²	8.9	4	12	108	1000	50A
P-1+N-1000/10V	KP075410V	10mm ²	8.9	4	12	108	1000	63A
P-1+N-1000/13V	KP075413V	10mm ²	8.9	4	12	108	1000	70A
P-1+N-1000/16V	KP075416V	16mm ²	8.9	4	12	108	1000	80A

Busbar Series

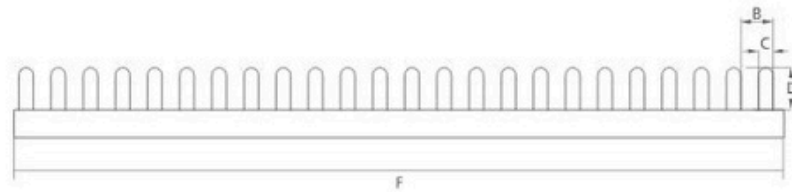

Pin type, 1P+N busbars

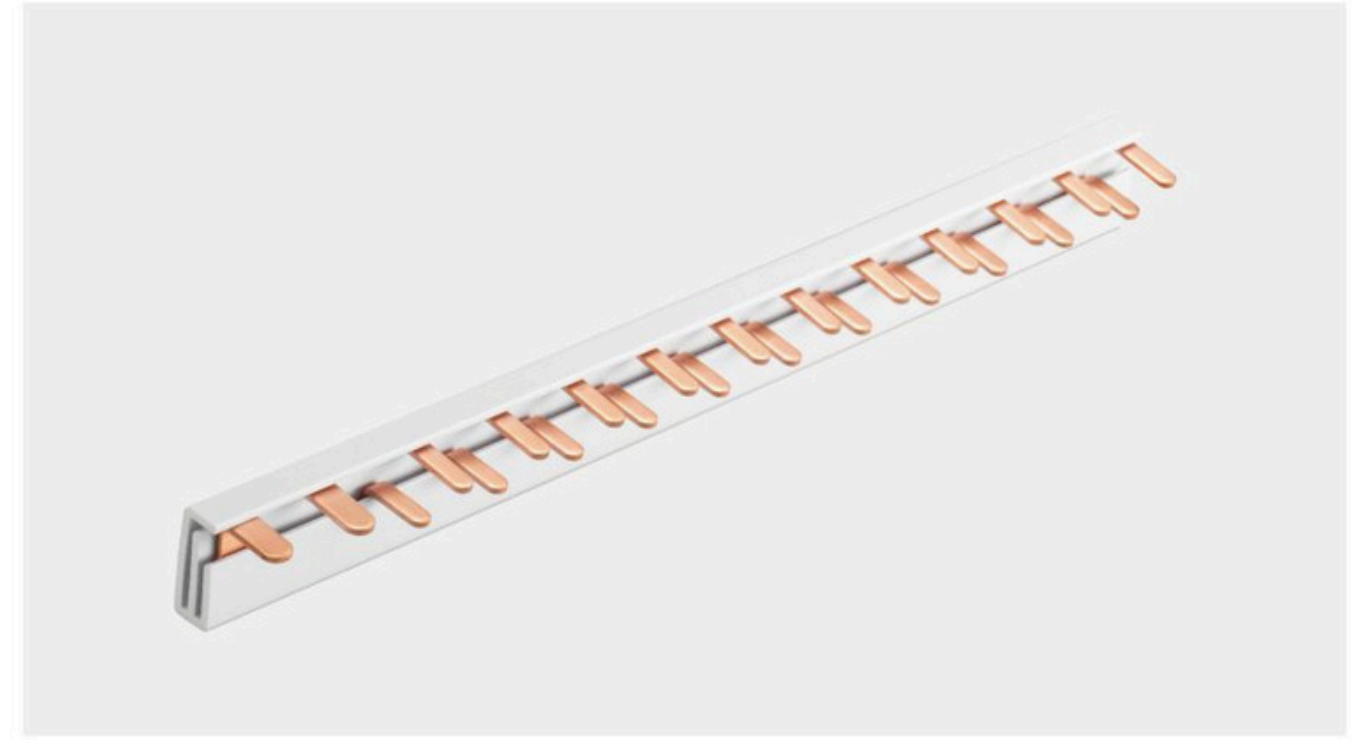

Description	Article No.	A Cross Section	B Distance(mm)	C Width of Pin(mm)	D Length of Pin(mm)	E Modules	F Length (mm)	G Reference Current
P-2L+6LN-140/8	KP081408	8mm ²	9	4	11.5	14	140	50A
P-2L+7LN-158/8	KP081608	8mm ²	9	4	11.5	16	158	50A
P-2L+8LN-176/8	KP081808	8mm ²	9	4	11.5	18	176	50A
P-2L+9LN-194/8	KP082008	8mm ²	9	4	11.5	20	194	50A
P-2L+10LN-212/8	KP082208	8mm ²	9	4	11.5	22	212	50A
P-2L+11LN-230/8	KP082408	8mm ²	9	4	11.5	24	230	50A
P-2L+6LN-140/10	KP081410	10mm ²	9	4	11.5	14	140	63A
P-2L+7LN-158/10	KP081610	10mm ²	9	4	11.5	16	158	63A
P-2L+8LN-176/10	KP081810	10mm ²	9	4	11.5	18	176	63A
P-2L+9LN-194/10	KP082010	10mm ²	9	4	11.5	20	194	63A
P-2L+10LN-212/10	KP082210	10mm ²	9	4	11.5	22	212	63A
P-2L+11LN-230/10	KP082410	10mm ²	9	4	11.5	24	230	63A

Busbar Series

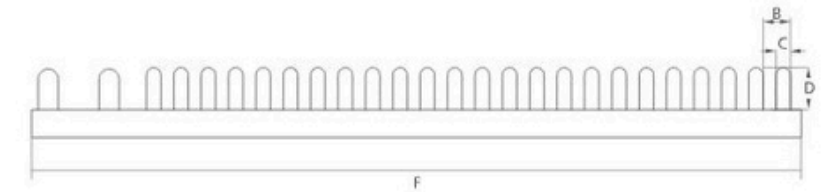

Pin type, 1P+N busbars

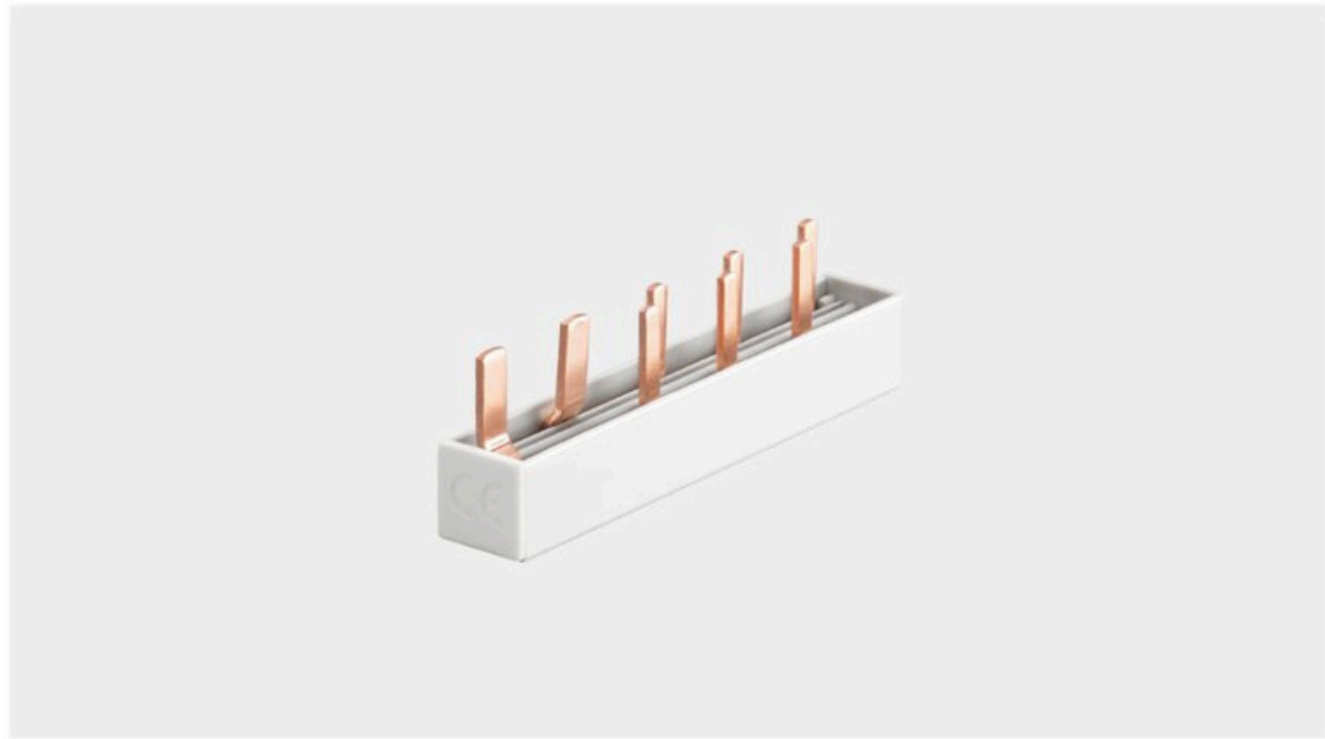

Description	Article No.	A Cross Section	B Distance(mm)	C Width of Pin(mm)	D Length of Pin(mm)	E Modules	F Length (mm)	G Reference Current
P-2L+2LN-72/10	KP090610	10mm ²	17.8	3.3	10.5	6	72	63A
P-2L+3LN-90/10	KP090810	10mm ²	17.8	3.3	10.5	8	90	63A
P-2L+4LN-108/10	KP091010	10mm ²	17.8	3.3	10.5	10	108	63A

Pin type, 2-phase combination busbars



Description	Article No.	A Cross Section	B Distance(mm)	C Width of Pin(mm)	D Length of Pin(mm)	E Modules	F Length (mm)	G Reference Current
P-5X2P+3X1P	KP101316C5	16mm ²	17.8	3.2	11.5	13	227	80A
P-5X2P+4X1P	KP101416C5	16mm ²	17.8	3.2	11.5	14	245	80A
P-5X2P+5X1P	KP101516C5	16mm ²	17.8	3.2	11.5	13	262	80A
P-5X2P+6X1P	KP101616C5	16mm ²	17.8	3.2	11.5	14	280	80A
P-6X2P+3X1P	KP101516C6	16mm ²	17.8	3.2	11.5	13	262	80A
P-6X2P+4X1P	KP101516C6	16mm ²	17.8	3.2	11.5	14	280	80A
P-6X2P+5X1P	KP101516C6	16mm ²	17.8	3.2	11.5	13	297	80A
P-7X2P+3X1P	KP101716C7	16mm ²	17.8	3.2	11.5	14	297	80A
P-7X2P+4X1P	KP101816C7	16mm ²	17.8	3.2	11.5	13	315	80A
P-8X2P+2X1P	KP101816C8	16mm ²	17.8	3.2	11.5	14	315	80A

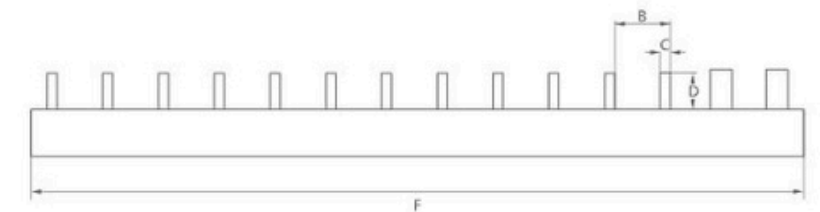
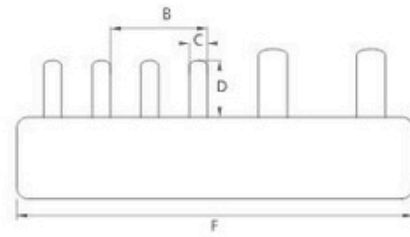

Pin type, 1P+N-LE busbars

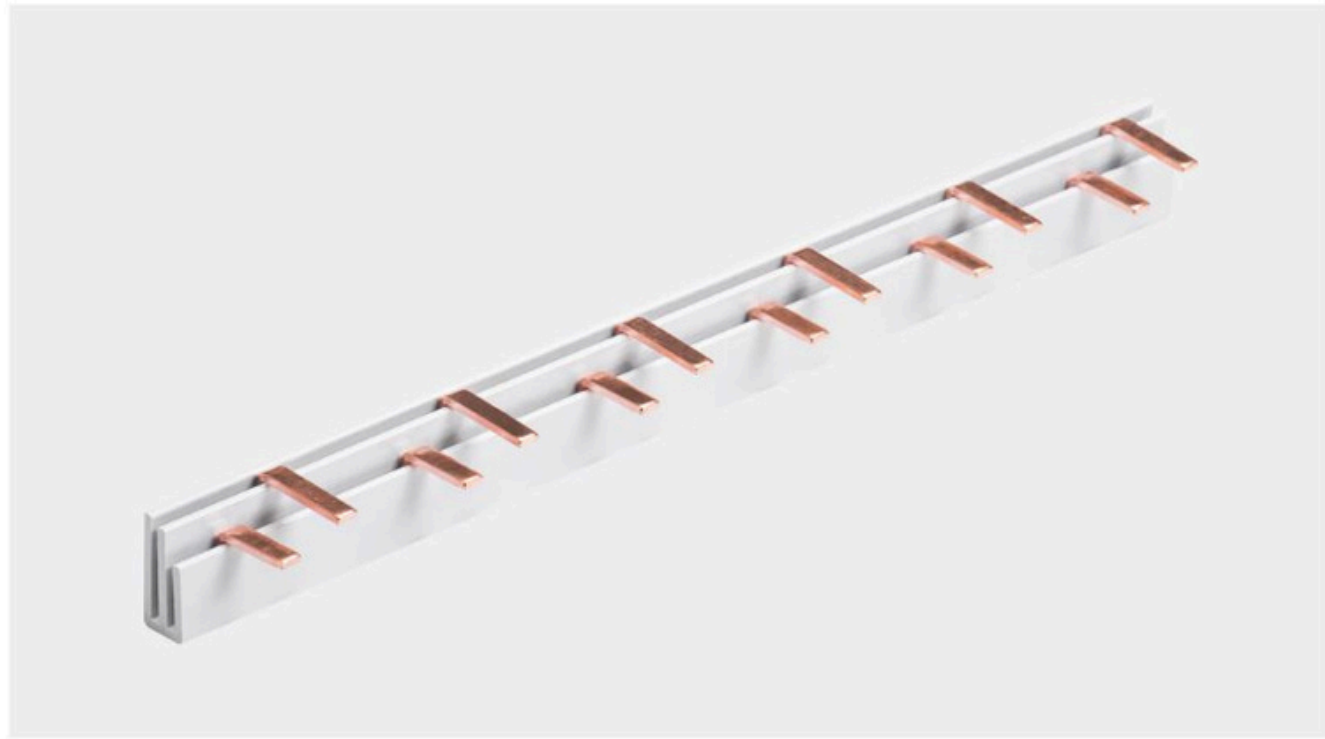

Description	Article No.	A Cross Section	B1 Distance (mm)	B2 Distance (mm)	C Width of Pin(mm)	D Length of Pin(mm)	E Modules	F Length (mm)	G Reference Current
P-1+N-LE-210/8	KP071208	8mm ²	9	27	4	14.5	12	210	50A
P-1+N-LE-210/10	KP071210	10mm ²	9	27	4	14.5	12	210	63A
P-1+N-LE-210/13	KP071213	13mm ²	9	27	4	14.5	12	210	70A
P-1+N-LE-210/16	KP071216	16mm ²	9	27	4	14.5	12	210	80A
P-1+N-LE-1000/8	KP075408	8mm ²	9	27	4	14.5	54	1000	50A
P-1+N-LE-1000/10	KP075410	10mm ²	9	27	4	14.5	54	1000	63A
P-1+N-LE-1000/13	KP075413	13mm ²	9	27	4	14.5	54	1000	70A
P-1+N-LE-1000/16	KP075416	16mm ²	9	27	4	14.5	54	1000	80A

Pin type, 3L+3N busbars

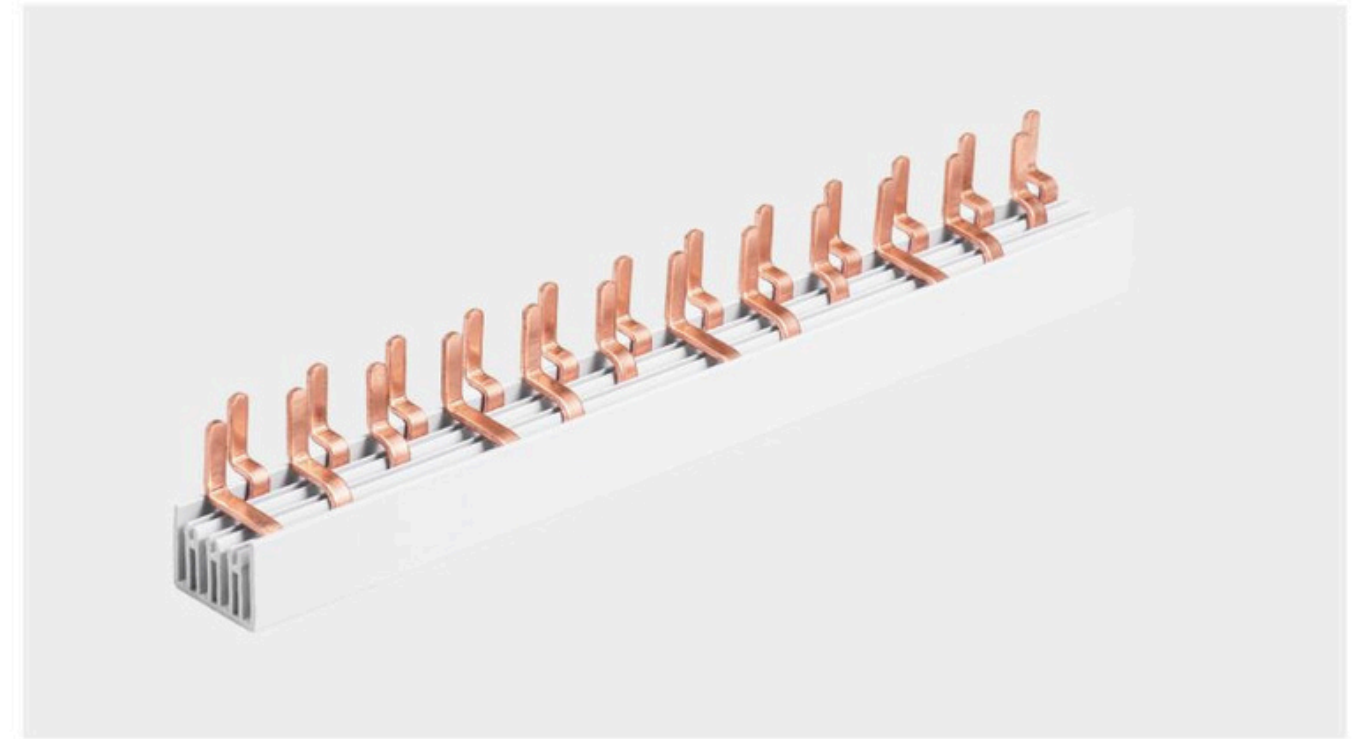

Description	Article No.	A Cross Section	B Distance(mm)	C Width of Pin(mm)	D Length of Pin(mm)	E Modules	F Length (mm)	G Reference Current
P-3L+3N-210/8(1P)	KPN1208	8mm ²	8.9	4	15	24	210	50A
P-3L+3N-210/10(1P)	KPN1210	10mm ²	8.9	4	15	24	210	63A
P-3L+3N-210/13(1P)	KPN1213	13mm ²	8.9	4	15	24	210	70A
P-3L+3N-210/16(1P)	KPN1216	16mm ²	8.9	4	15	24	210	80A
P-3L+3N-1000/8(1P)	KPN5408	8mm ²	8.9	4	15	108	1000	50A
P-3L+3N-1000/10(1P)	KPN5410	10mm ²	8.9	4	15	108	1000	63A
P-3L+3N-1000/13(1P)	KPN5413	13mm ²	8.9	4	15	108	1000	70A
P-3L+3N-1000/16(1P)	KPN5416	16mm ²	8.9	4	15	108	1000	80A

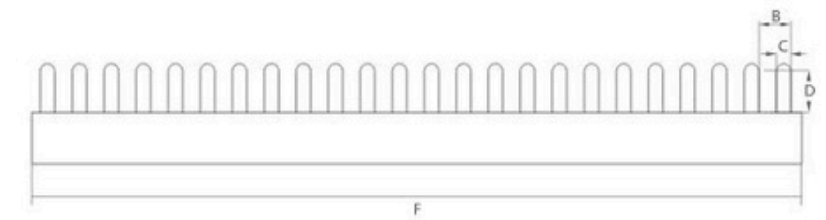
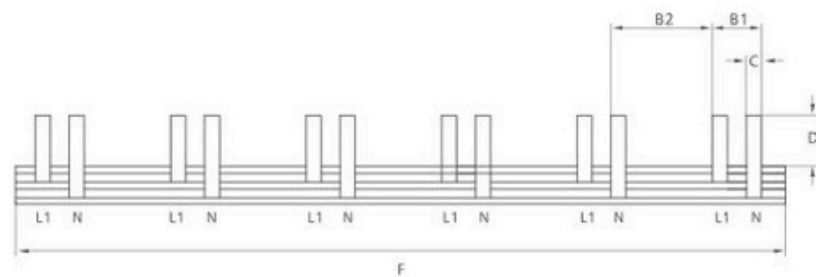

Pin type, 1-phase busbars (C45)



Description	Article No.	A Cross Section	B Pitch(mm)	C Width of Pin(mm)	D Length of Pin(mm)	E Modules	F Length (mm)	G Reference Current
C-1L-210/8	KC011208	8mm ²	17.8	5.5	11.5	12	210	50A
C-1L-210/10	KC011210	10mm ²	17.8	5.5	11.5	12	210	63A
C-1L-210/13	KC011213	13mm ²	17.8	5.5	11.5	12	210	70A
C-1L-210/16	KC011216	16mm ²	17.8	5.5	11.5	12	210	80A
C-1L-1000/8	KC015408	8mm ²	17.8	5.5	11.5	54	1000	50A
C-1L-1000/10	KC015410	10mm ²	17.8	5.5	11.5	54	1000	63A
C-1L-1000/13	KC015413	13mm ²	17.8	5.5	11.5	54	1000	70A
C-1L-1000/16	KC015416	16mm ²	17.8	5.5	11.5	54	1000	80A
C-1L-1016/8	KC015708	8mm ²	17.8	5.5	11.5	57	1016	50A
C-1L-1016/10	KC015710	10mm ²	17.8	5.5	11.5	57	1016	63A
C-1L-1016/13	KC015713	13mm ²	17.8	5.5	11.5	57	1016	70A
C-1L-1016/16	KC015716	16mm ²	17.8	5.5	11.5	57	1016	80A

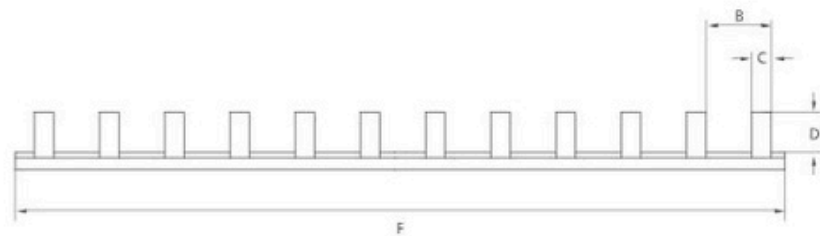

Busbar Series

Pin type, 2-phase busbars (C45)



Description	Article No.	A Cross Section	B Distance (mm)	C Width of Pin(mm)	D Length of Pin(mm)	E Modules	F Length (mm)	G Reference Current
C-2L-210/8	KC021208	8mm ²	17.8	5.5	11.5	12	210	50A
C-2L-210/10	KC021210	10mm ²	17.8	5.5	11.5	12	210	63A
C-2L-210/13	KC021213	13mm ²	17.8	5.5	11.5	12	210	70A
C-2L-210/16	KC021216	16mm ²	17.8	5.5	11.5	12	210	80A
C-2L-1000/8	KC025408	8mm ²	17.8	5.5	11.5	54	1000	50A
C-2L-1000/10	KC025410	10mm ²	17.8	5.5	11.5	54	1000	63A
C-2L-1000/13	KC025413	13mm ²	17.8	5.5	11.5	54	1000	70A
C-2L-1000/16	KC025416	16mm ²	17.8	5.5	11.5	54	1000	80A
C-2L-1016/8	KC025708	8mm ²	17.8	5.5	11.5	56	1016	50A
C-2L-1016/10	KC025710	10mm ²	17.8	5.5	11.5	56	1016	63A
C-2L-1016/13	KC025713	13mm ²	17.8	5.5	11.5	56	1016	70A
C-2L-1016/16	KC025716	16mm ²	17.8	5.5	11.5	56	1016	80A

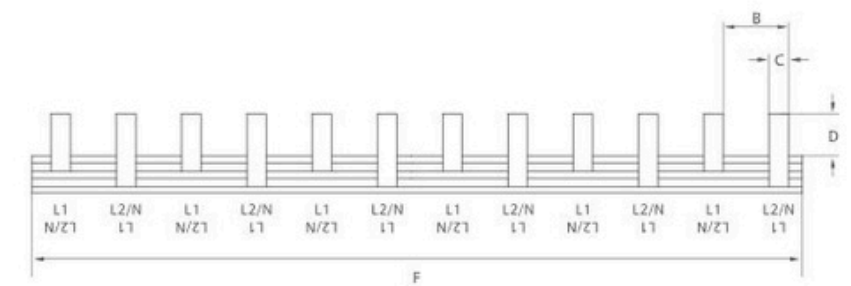

Busbar Series

Pin type, 3-phase busbars (C45)



Description	Article No.	A Cross Section	B Distance (mm)	C Width of Pin(mm)	D Length of Pin(mm)	E Modules	F Length (mm)	G Reference Current
C-3L-210/8	KC031208	8mm ²	17.8	5.5	11.5	12	210	50A
C-3L-210/10	KC031210	10mm ²	17.8	5.5	11.5	12	210	63A
C-3L-210/13	KC031213	13mm ²	17.8	5.5	11.5	12	210	70A
C-3L-210/16	KC032216	16mm ²	17.8	5.5	11.5	12	210	80A
C-3L-1000/8	KC035408	8mm ²	17.8	5.5	11.5	54	1000	50A
C-3L-1000/10	KC035410	10mm ²	17.8	5.5	11.5	54	1000	63A
C-3L-1000/13	KC035413	13mm ²	17.8	5.5	11.5	54	1000	70A
C-3L-1000/16	KC035416	16mm ²	17.8	5.5	11.5	54	1000	80A
C-3L-1016/8	KC035708	8mm ²	17.8	5.5	11.5	57	1016	50A
C-3L-1016/10	KC035710	10mm ²	17.8	5.5	11.5	57	1016	63A
C-3L-1016/13	KC035713	13mm ²	17.8	5.5	11.5	57	1016	70A
C-3L-1016/16	KC035716	16mm ²	17.8	5.5	11.5	57	1016	80A

Busbar Series

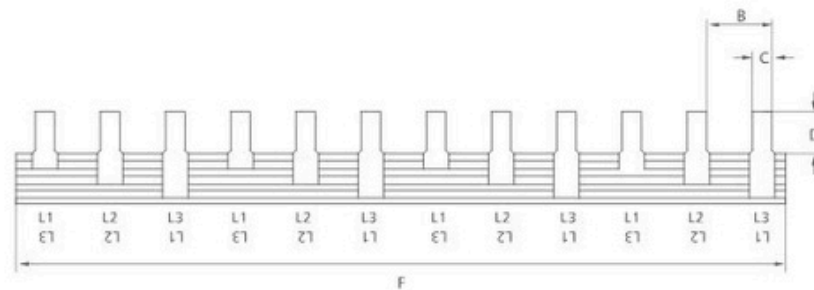

Pin type, 4-phase busbars (C45)



Description	Article No.	A Cross Section	B Distance (mm)	C Width of Pin(mm)	D Length of Pin(mm)	E Modules	F Length (mm)	G Reference Current
C-4L-210/8	KC041208	8mm ²	17.8	5	11.5	12	210	50A
C-4L-210/10	KC041210	10mm ²	17.8	5	11.5	12	210	63A
C-4L-210/13	KC041213	13mm ²	17.8	5	11.5	12	210	70A
C-4L-210/16	KC041216	16mm ²	17.8	5	11.5	12	210	80A
C-4L-1016/8	KC045408	8mm ²	17.8	5	11.5	56	1016	50A
C-4L-1016/10	KC045410	10mm ²	17.8	5	11.5	56	1016	63A
C-4L-1016/13	KC045413	13mm ²	17.8	5	11.5	56	1016	70A
C-4L-1016/16	KC045416	16mm ²	17.8	5	11.5	56	1016	80A

Busbar Series

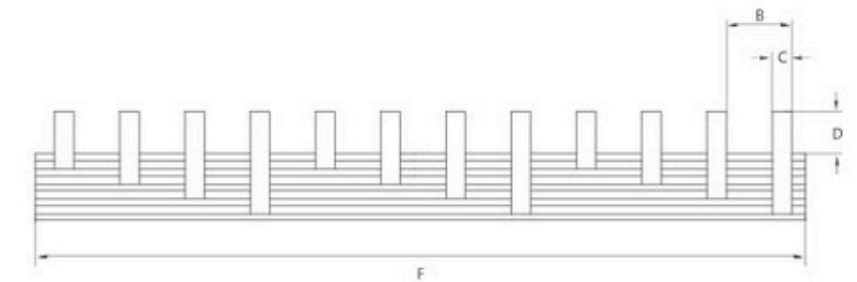

Pin type, 1-phasebusbars (M5.5)

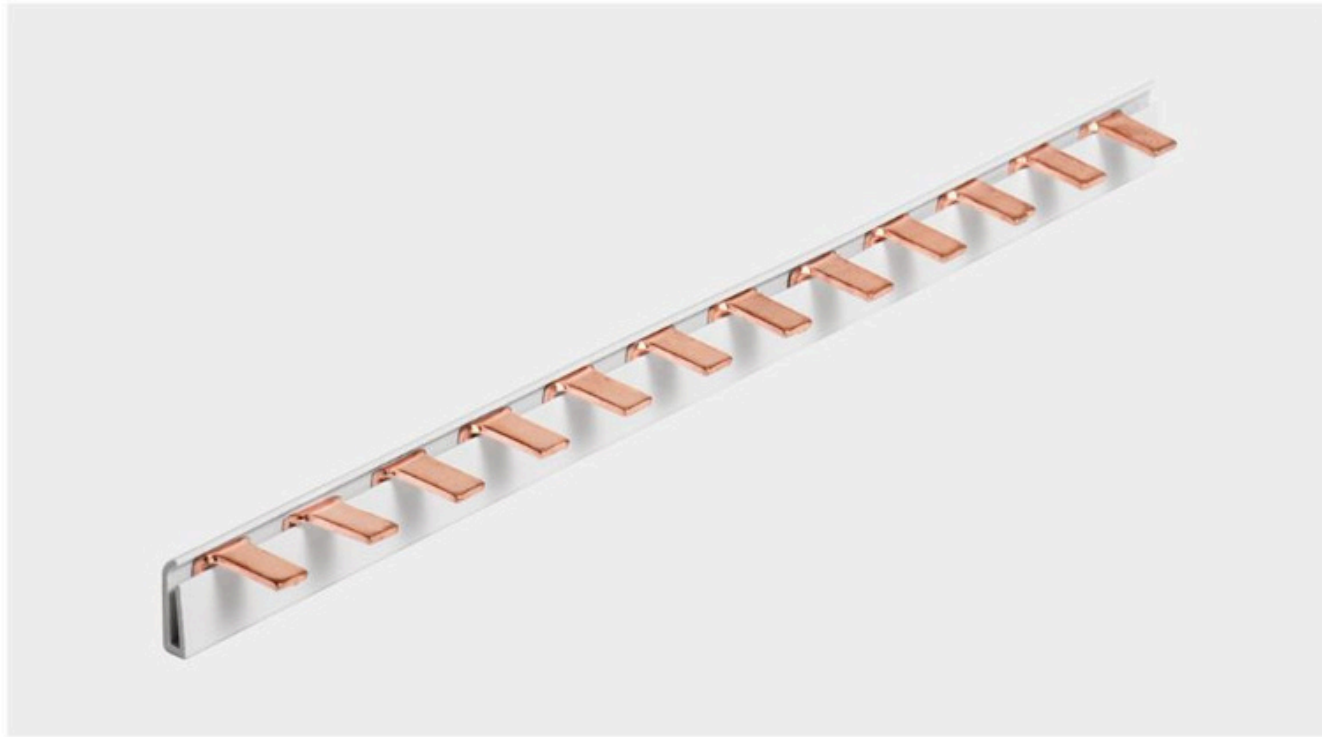

Description	Article No.	A Cross Section	B Distance (mm)	C Width of Pin(mm)	D Length of Pin(mm)	E Modules	F Length (mm)	G Reference Current
P-1L-210/8C	KP011208C	8mm ²	17.8	5.5	11.5	12	210	50A
P-1L-210/10C	KP011210C	10mm ²	17.8	5.5	11.5	12	210	63A
P-1L-210/13C	KP011213C	13mm ²	17.8	5.5	11.5	12	210	70A
P-1L-210/16C	KP011216C	16mm ²	17.8	5.5	11.5	12	210	80A
P-1L-1000/8C	KP015408C	8mm ²	17.8	5.5	11.5	54	1000	50A
P-1L-1000/10C	KP015410C	10mm ²	17.8	5.5	11.5	54	1000	63A
P-1L-1000/13C	KP015413C	13mm ²	17.8	5.5	11.5	54	1000	70A
P-1L-1000/16C	KP015416C	16mm ²	17.8	5.5	11.5	54	1000	80A
P-1L-1016/8C	KP015708C	8mm ²	17.8	5.5	11.5	57	1016	50A
P-1L-1016/10C	KP015710C	10mm ²	17.8	5.5	11.5	57	1016	63A
P-1L-1016/13C	KP015713C	13mm ²	17.8	5.5	11.5	57	1016	70A
P-1L-1016/16C	KP015716C	16mm ²	17.8	5.5	11.5	57	1016	80A
P-1L-1000/25C	KP015425C	25mm ²	17.8	6	11.5	54	1000	100A

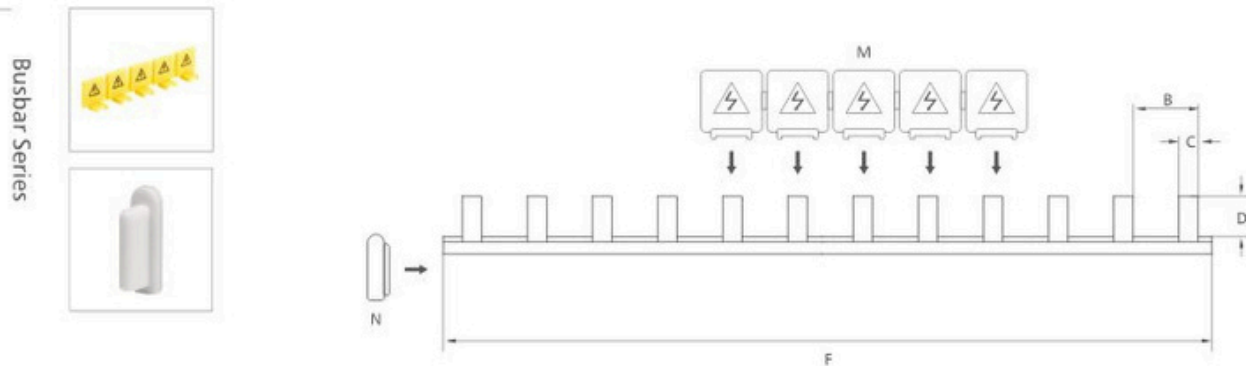

Pin type, 2-phasebusbars (M5.5)

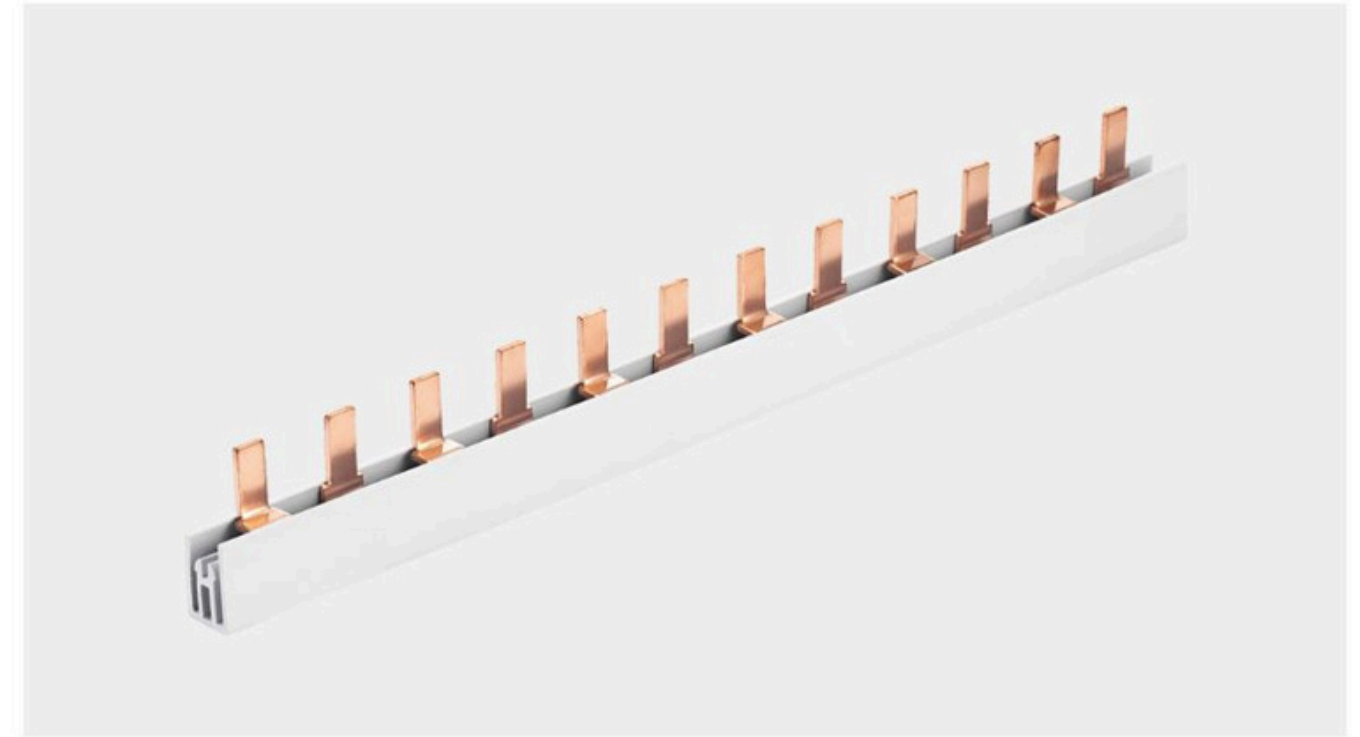

Description	Article No.	A Cross Section	B Distance (mm)	C Width of Pin(mm)	D Length of Pin(mm)	E Modules	F Length (mm)	G Reference Current
P-2L-210/8C	KP021208C	8mm ²	17.8	5.5	11.5	12	210	50A
P-2L-210/10C	KP021210C	10mm ²	17.8	5.5	11.5	12	210	63A
P-2L-210/13C	KP021213C	13mm ²	17.8	5.5	11.5	12	210	70A
P-2L-210/16C	KP021216C	16mm ²	17.8	5.5	11.5	12	210	80A
P-2L-1000/8C	KP025408C	8mm ²	17.8	5.5	11.5	54	1000	50A
P-2L-1000/10C	KP025410C	10mm ²	17.8	5.5	11.5	54	1000	63A
P-2L-1000/13C	KP025413C	13mm ²	17.8	5.5	11.5	54	1000	70A
P-2L-1000/16C	KP025416C	16mm ²	17.8	5.5	11.5	54	1000	80A
P-2L-1016/8C	KP025608C	8mm ²	17.8	5.5	11.5	56	1016	50A
P-2L-1016/10C	KP025610C	10mm ²	17.8	5.5	11.5	56	1016	63A
P-2L-1016/13C	KP025613C	13mm ²	17.8	5.5	11.5	56	1016	70A
P-2L-1016/16C	KP025616C	16mm ²	17.8	5.5	11.5	56	1016	80A
P-2L-1000/25C	KP025425C	25mm ²	17.8	6	11.5	54	1000	100A

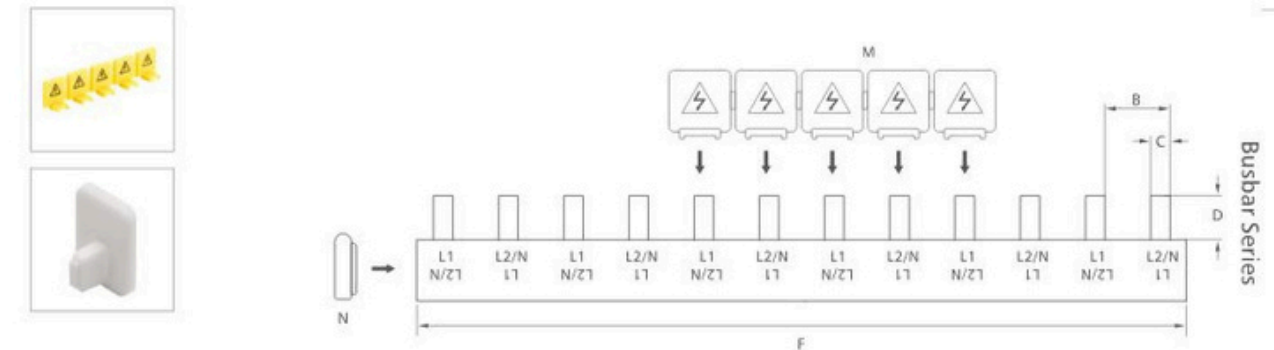

Pin type, 3-phase busbars (M5.5)

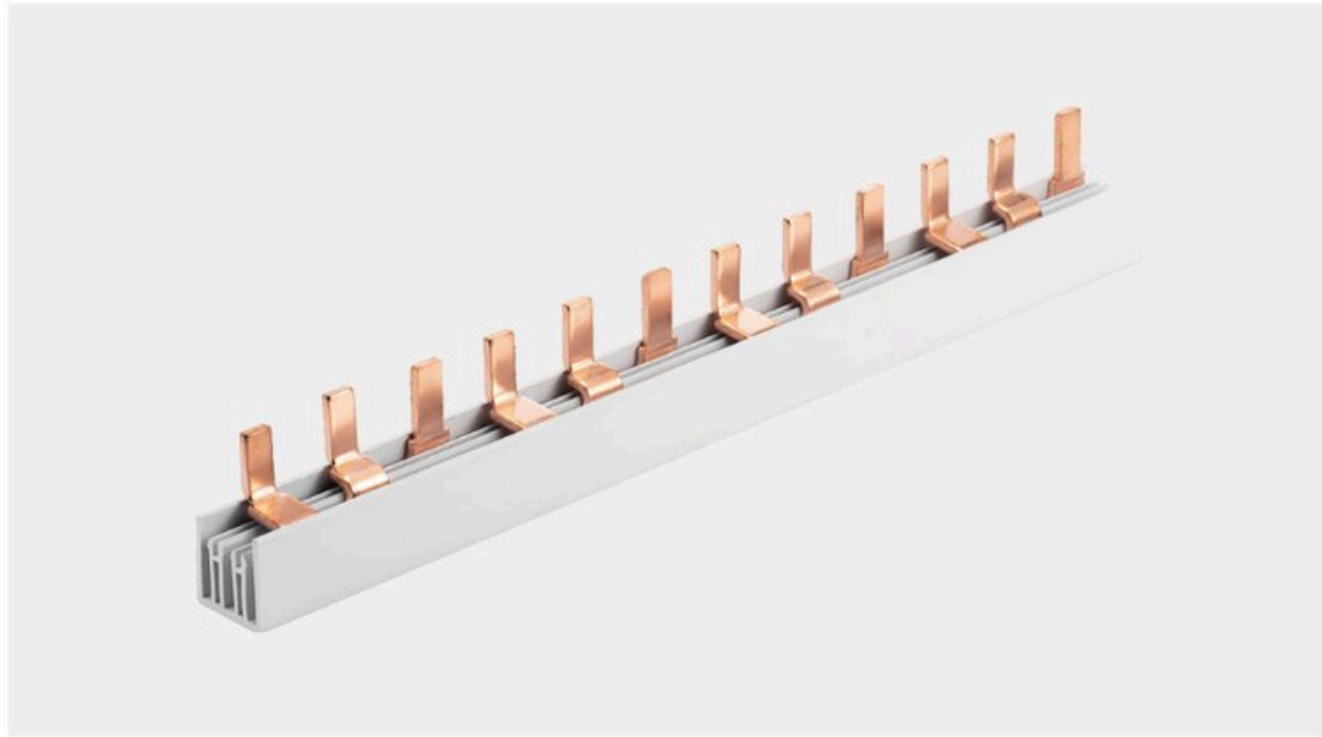

Description	Article No.	A Cross Section	B Distance (mm)	C Width of Pin(mm)	D Length of Pin(mm)	E Modules	F Length (mm)	G Reference Current
P-3L-210/8C	KP031208C	8mm ²	17.8	5.5	11.5	12	210	50A
P-3L-210/10C	KP031210C	10mm ²	17.8	5.5	11.5	12	210	63A
P-3L-210/13C	KP031213C	13mm ²	17.8	5.5	11.5	12	210	70A
P-3L-210/16C	KP031216C	16mm ²	17.8	5.5	11.5	12	210	80A
P-3L-1000/8C	KP035408C	8mm ²	17.8	5.5	11.5	54	1000	50A
P-3L-1000/10C	KP035410C	10mm ²	17.8	5.5	11.5	54	1000	63A
P-3L-1000/13C	KP035413C	13mm ²	17.8	5.5	11.5	54	1000	70A
P-3L-1000/16C	KP035416C	16mm ²	17.8	5.5	11.5	54	1000	80A
P-3L-1016/8C	KP035708C	8mm ²	17.8	5.5	11.5	57	1016	50A
P-3L-1016/10C	KP035710C	10mm ²	17.8	5.5	11.5	57	1016	63A
P-3L-1016/13C	KP035713C	13mm ²	17.8	5.5	11.5	57	1016	70A
P-3L-1016/16C	KP035716C	16mm ²	17.8	5.5	11.5	57	1016	80A
P-3L-1000/25C	KP035425C	25mm ²	17.8	6	11.5	54	1000	100A

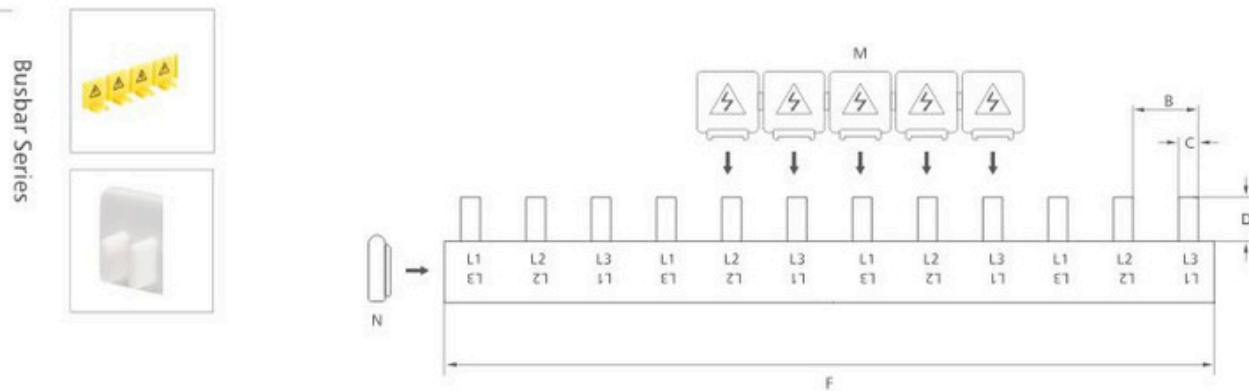

Fork type, 1-phase busbars(M6)



Description	Article No.	A Cross Section	B Distance (mm)	C Width of Fork(mm)	D Length of Fork(mm)	E Modules	F Length (mm)	G Reference Current
G-1L-210/8	KG011208	8mm ²	17.8	11	12.5	12	210	50A
G-1L-210/10	KG011210	10mm ²	17.8	11	12.5	12	210	63A
G-1L-210/13	KG011213	13mm ²	17.8	11	12.5	12	210	70A
G-1L-210/16	KG011216	16mm ²	17.8	11	12.5	12	210	80A
G-1L-1000/8	KG015408	8mm ²	17.8	11	12.5	54	1000	50A
G-1L-1000/10	KG015410	10mm ²	17.8	11	12.5	54	1000	63A
G-1L-1000/13	KG015413	13mm ²	17.8	11	12.5	54	1000	70A
G-1L-1000/16	KG015416	16mm ²	17.8	11	12.5	54	1000	80A
G-1L-1016/8	KG015708	8mm ²	17.8	11	12.5	57	1016	50A
G-1L-1016/10	KG015710	10mm ²	17.8	11	12.5	57	1016	63A
G-1L-1016/13	KG015713	13mm ²	17.8	11	12.5	57	1016	70A
G-1L-1016/16	KG015716	16mm ²	17.8	11	12.5	57	1016	80A

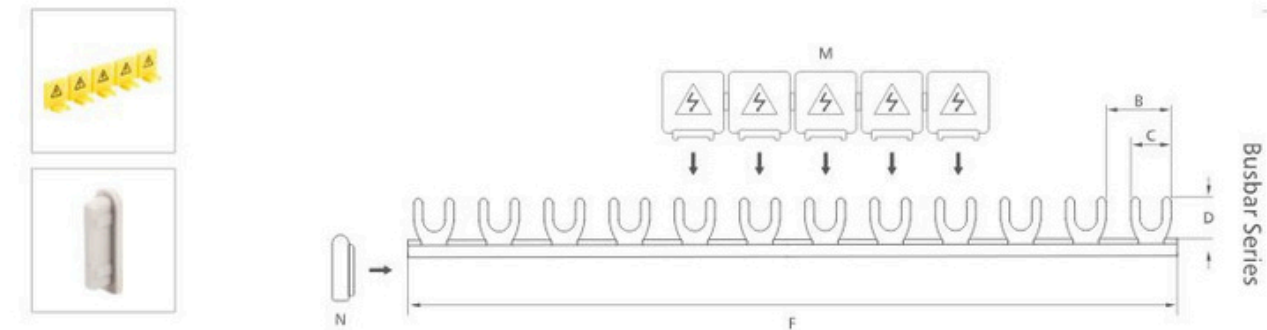

Fork type, 4-phase busbars(M6)

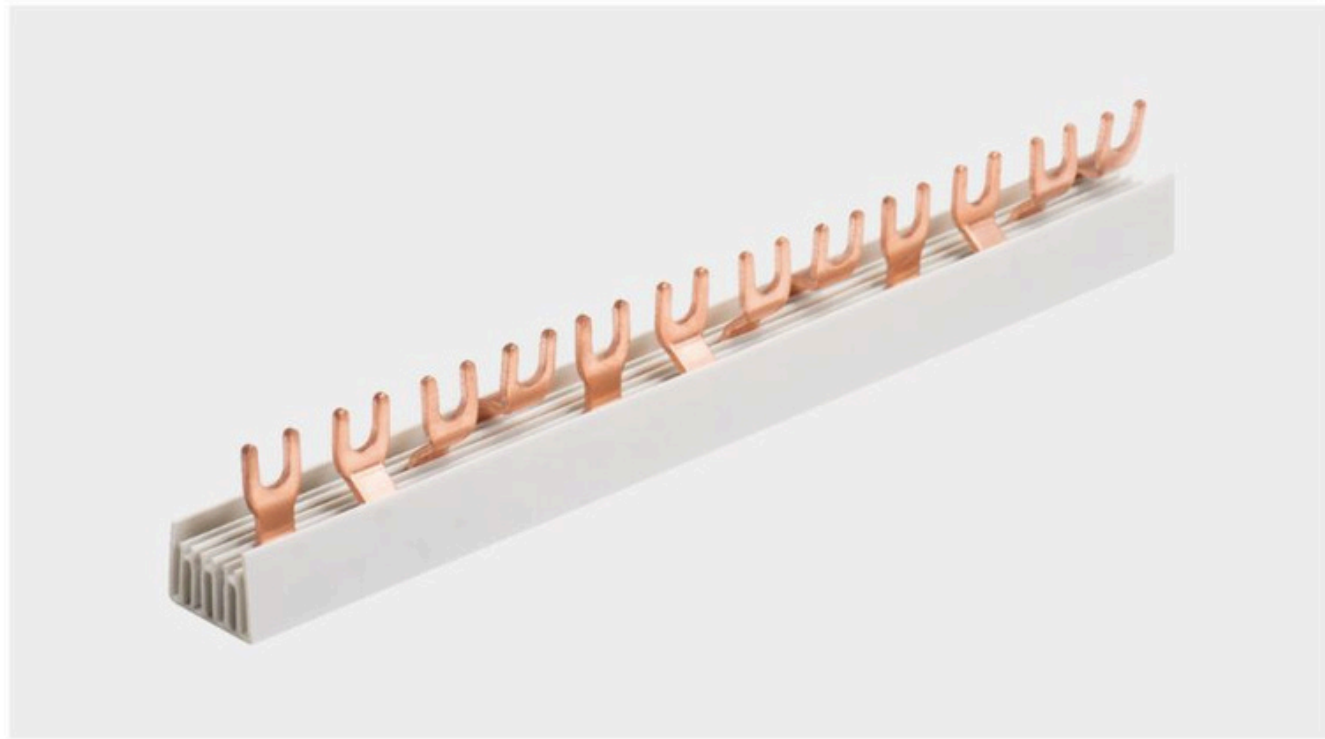

Description	Article No.	A Cross Section	B Distance (mm)	C Width of Fork(mm)	D Length of Fork(mm)	E Modules	F Length (mm)	G Reference Current
G-4L-210/8C	KG041208C	8mm ²	17.8	11	13.5	12	210	50A
G-4L-210/10C	KG041210C	10mm ²	17.8	11	13.5	12	210	63A
G-4L-210/13C	KG041213C	13mm ²	17.8	11	13.5	12	210	70A
G-4L-210/16C	KG041216C	16mm ²	17.8	11	13.5	12	210	80A
G-4L-1016/8C	KG045608C	8mm ²	17.8	11	13.5	56	1016	50A
G-4L-1016/10C	KG045610C	10mm ²	17.8	11	13.5	56	1016	63A
G-4L-1016/13C	KG045613C	13mm ²	17.8	11	13.5	56	1016	70A
G-4L-1016/16C	KG045616C	16mm ²	17.8	11	13.5	56	1016	80A

Fork type, 3L+3N busbars (M6)

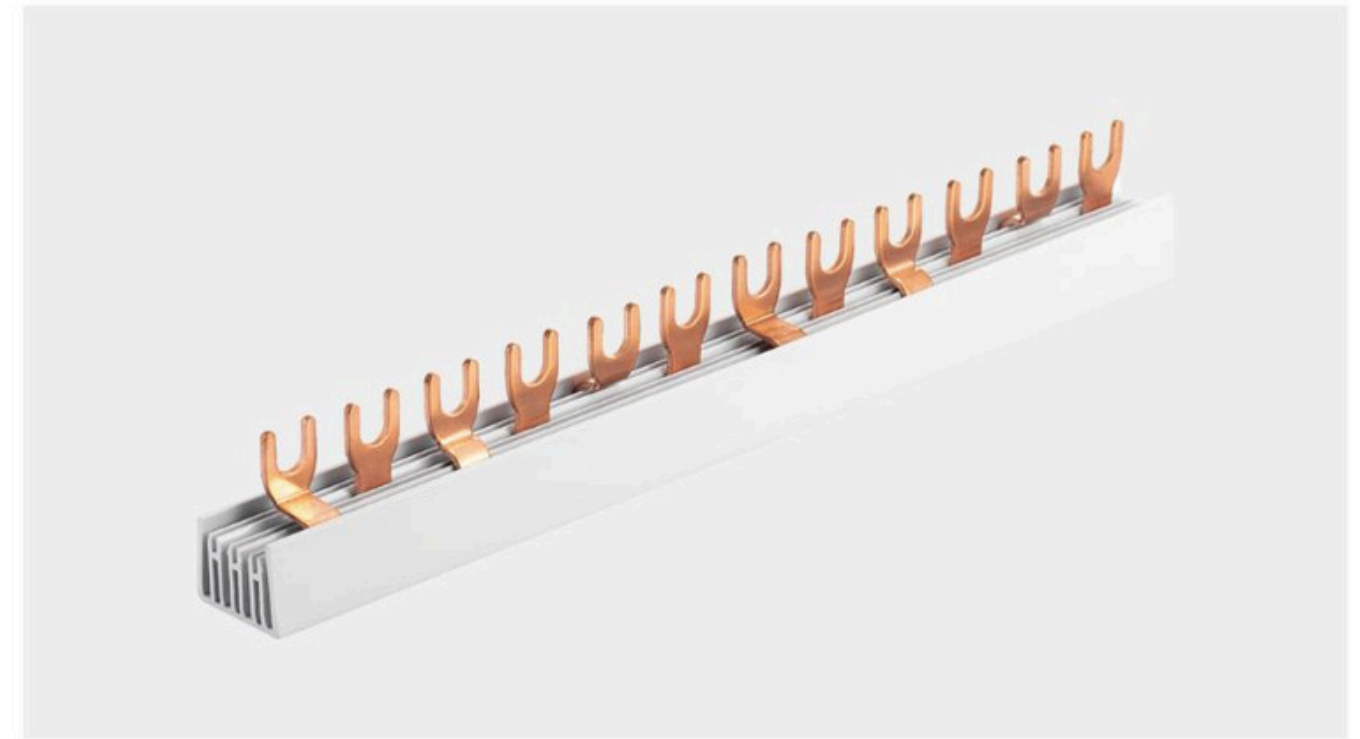

Description	Article No.	A Cross Section	B Distance (mm)	C Width of Fork(mm)	D Length of Fork(mm)	E Modules	F Length (mm)	G Reference Current
G-3L+3N-210/8C	KG051208C	8mm ²	17.8	11	13.5	12	210	50A
G-3L+3N-210/10C	KG051210C	10mm ²	17.8	11	13.5	12	210	63A
G-3L+3N-210/13C	KG051213C	13mm ²	17.8	11	13.5	12	210	70A
G-3L+3N-210/16C	KG051216C	16mm ²	17.8	11	13.5	12	210	80A
G-3L+3N-1000/8C	KG055408C	8mm ²	17.8	11	13.5	54	1000	50A
G-3L+3N-1000/10C	KG055410C	10mm ²	17.8	11	13.5	54	1000	63A
G-3L+3N-1000/13C	KG055413C	13mm ²	17.8	11	13.5	54	1000	70A
G-3L+3N-1000/16C	KG055416C	16mm ²	17.8	11	13.5	54	1000	80A

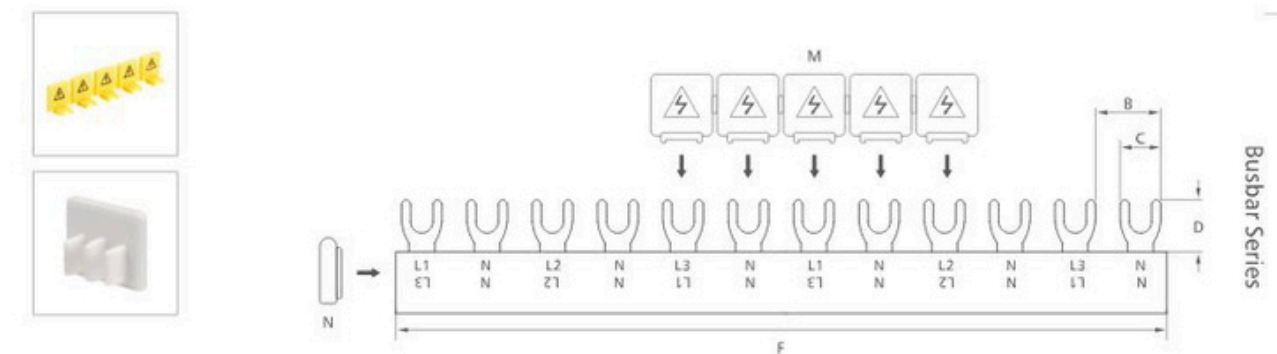
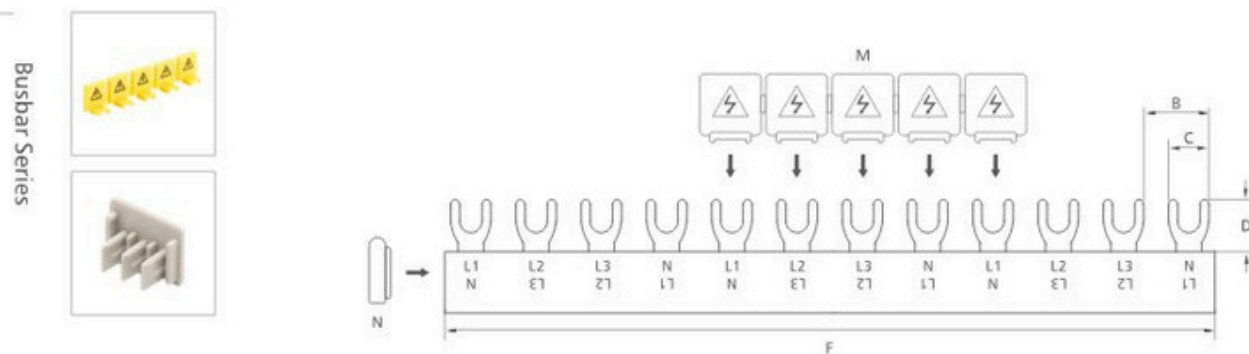

Pin type, 1-phase busbars



Description	Article No.	A Cross Section	B Distance (mm)	C Width of Pin(mm)	D Length of Pin(mm)	E Modules	F Length (mm)	G Reference Current
S-1L-210/8	KS011208	8mm ²	17.8	4	11.5	12	210	50A
S-1L-210/10	KS011210	10mm ²	17.8	4	11.5	12	210	63A
S-1L-210/13	KS011213	13mm ²	17.8	4	11.5	12	210	70A
S-1L-210/16	KS011216	16mm ²	17.8	4	11.5	12	210	80A
S-1L-1000/8	KS015408	8mm ²	17.8	4	11.5	54	1000	50A
S-1L-1000/10	KS015410	10mm ²	17.8	4	11.5	54	1000	63A
S-1L-1000/13	KS015413	13mm ²	17.8	4	11.5	54	1000	70A
S-1L-1000/16	KS015416	16mm ²	17.8	4	11.5	54	1000	80A
S-1L-1016/8	KS015708	8mm ²	17.8	4	11.5	57	1016	50A
S-1L-1016/10	KS015710	10mm ²	17.8	4	11.5	57	1016	63A
S-1L-1016/13	KS015713	13mm ²	17.8	4	11.5	57	1016	70A
S-1L-1016/16	KS015716	16mm ²	17.8	4	11.5	57	1016	80A

Pin type, 2-phase busbars

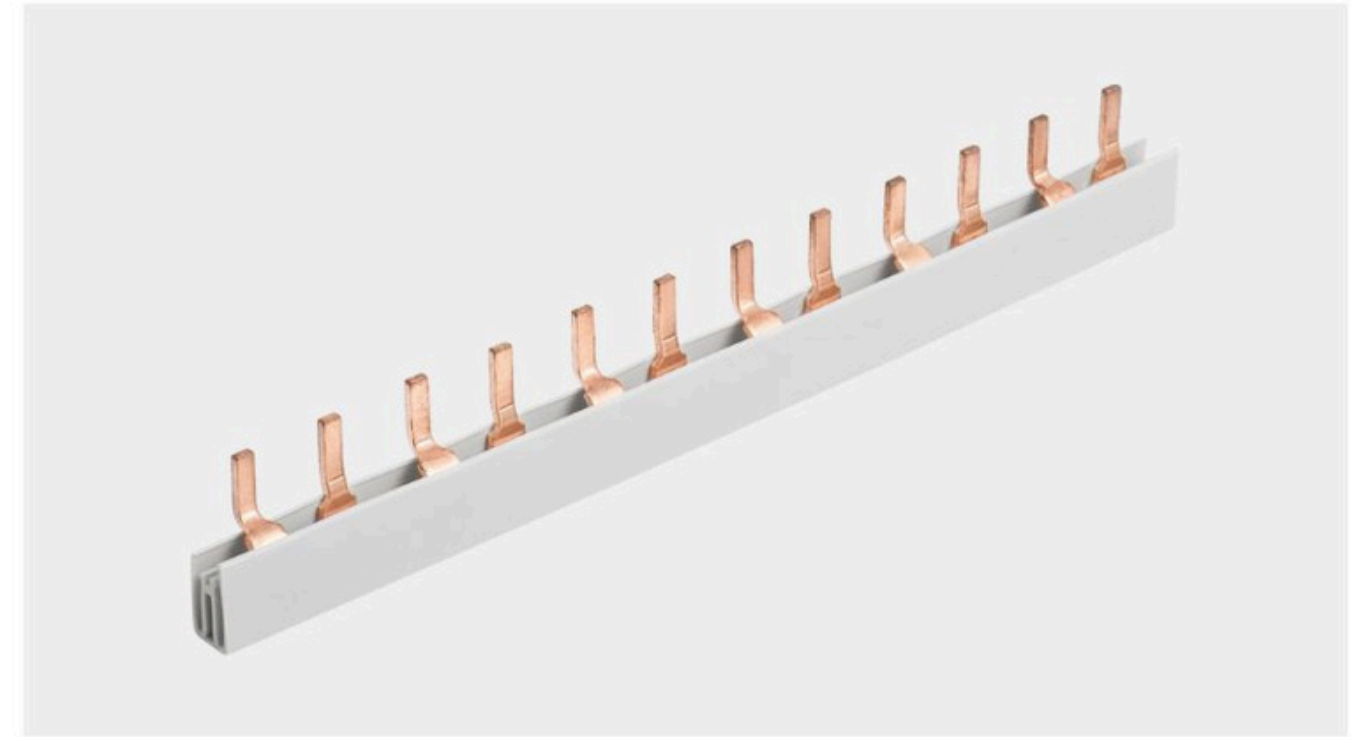

Description	Article No.	A Cross Section	B Distance (mm)	C Width of Pin(mm)	D Length of Pin(mm)	E Modules	F Length (mm)	G Reference Current
S-2L-210/8	KS021208	8mm ²	17.8	4	12.5	12	210	50A
S-2L-210/10	KS021210	10mm ²	17.8	4	12.5	12	210	63A
S-2L-210/13	KS021213	13mm ²	17.8	4	12.5	12	210	70A
S-2L-210/16	KS021216	16mm ²	17.8	4	12.5	12	210	80A
S-2L-1000/8	KS025408	8mm ²	17.8	4	12.5	54	1000	50A
S-2L-1000/10	KS025410	10mm ²	17.8	4	12.5	54	1000	63A
S-2L-1000/13	KS025413	13mm ²	17.8	4	12.5	54	1000	70A
S-2L-1000/16	KS025416	16mm ²	17.8	4	12.5	54	1000	80A
S-2L-1016/8	KS025608	8mm ²	17.8	4	12.5	56	1016	50A
S-2L-1016/10	KS025610	10mm ²	17.8	4	12.5	56	1016	63A
S-2L-1016/13	KS025613	13mm ²	17.8	4	12.5	56	1016	70A
S-2L-1016/16	KS025616	16mm ²	17.8	4	12.5	56	1016	80A

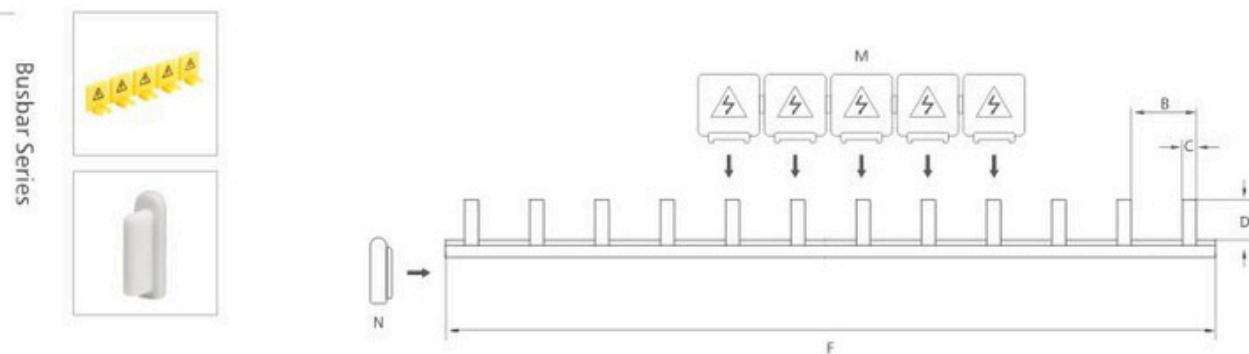

Busbar Series

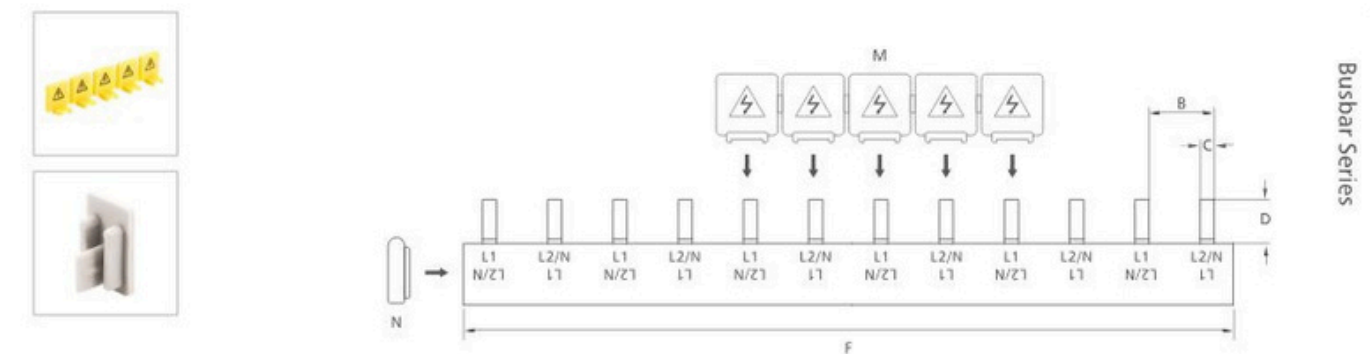

Busbar Series

Pin type, 3-phase busbars

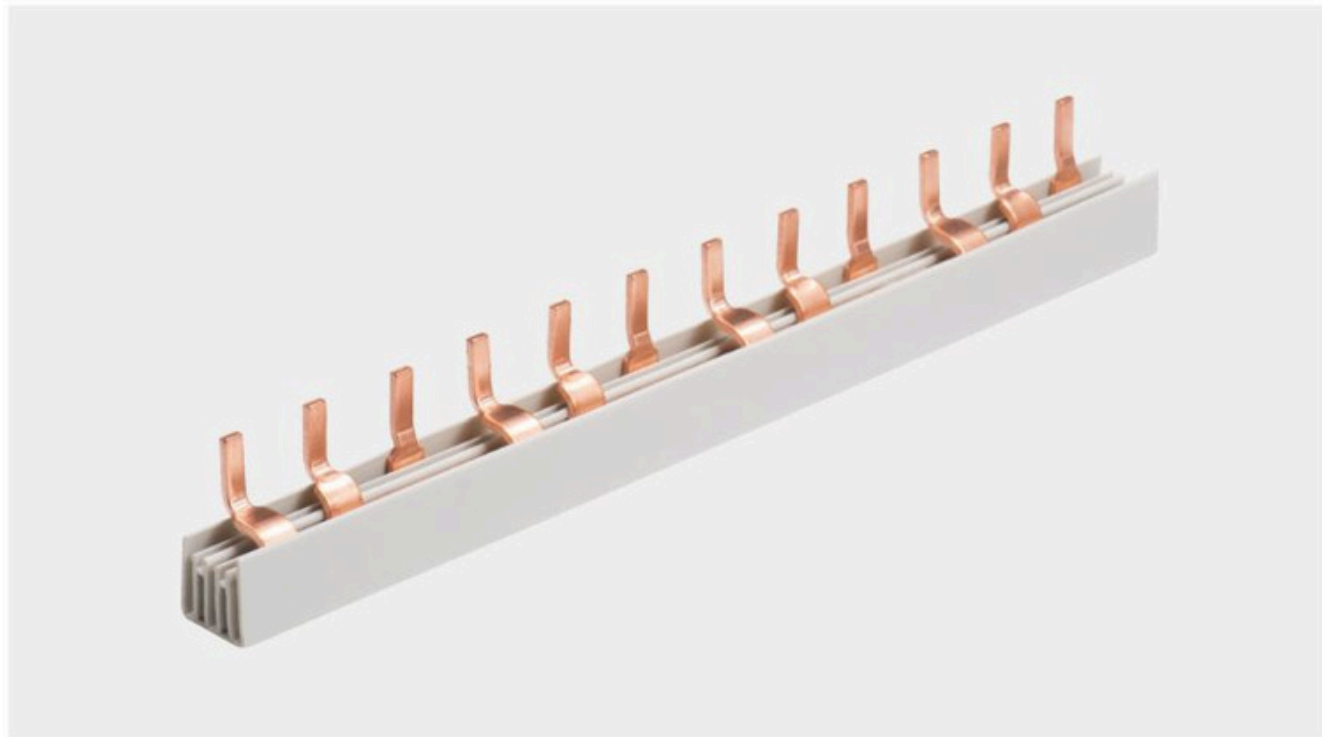

Description	Article No.	A Cross Section	B Distance (mm)	C Width of Pin(mm)	D Length of Pin(mm)	E Modules	F Length (mm)	G Reference Current
S-3L-210/8	KS031208	8mm ²	17.8	4	12.5	12	210	50A
S-3L-210/10	KS031210	10mm ²	17.8	4	12.5	12	210	63A
S-3L-210/13	KS031213	13mm ²	17.8	4	12.5	12	210	70A
S-3L-210/16	KS031216	16mm ²	17.8	4	12.5	12	210	80A
S-3L-1000/8	KS035408	8mm ²	17.8	4	12.5	54	1000	50A
S-3L-1000/10	KS035410	10mm ²	17.8	4	12.5	54	1000	63A
S-3L-1000/13	KS035413	13mm ²	17.8	4	12.5	54	1000	70A
S-3L-1000/16	KS035416	16mm ²	17.8	4	12.5	54	1000	80A
S-3L-1016/8	KS035708	8mm ²	17.8	4	12.5	57	1016	50A
S-3L-1016/10	KS035710	10mm ²	17.8	4	12.5	57	1016	63A
S-3L-1016/13	KS035713	13mm ²	17.8	4	12.5	57	1016	70A
S-3L-1016/16	KS035716	16mm ²	17.8	4	12.5	57	1016	80A

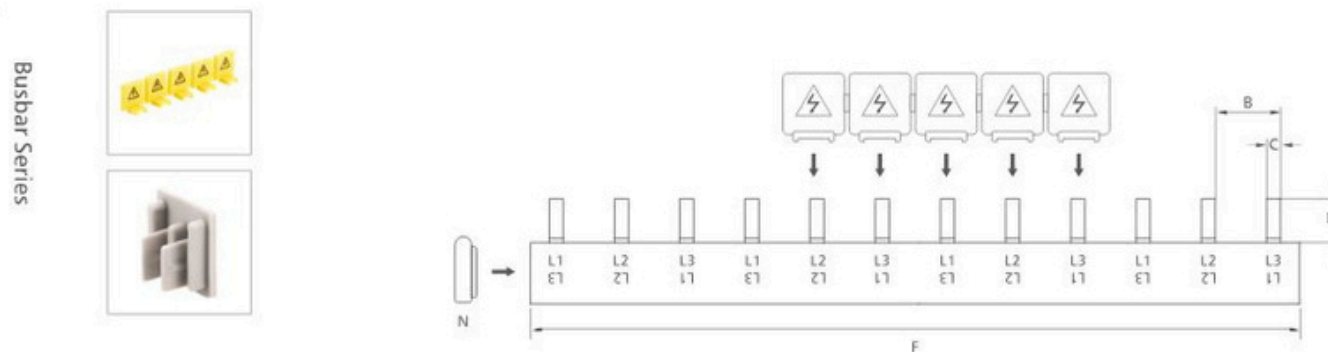

Pin type, 4-phase busbars

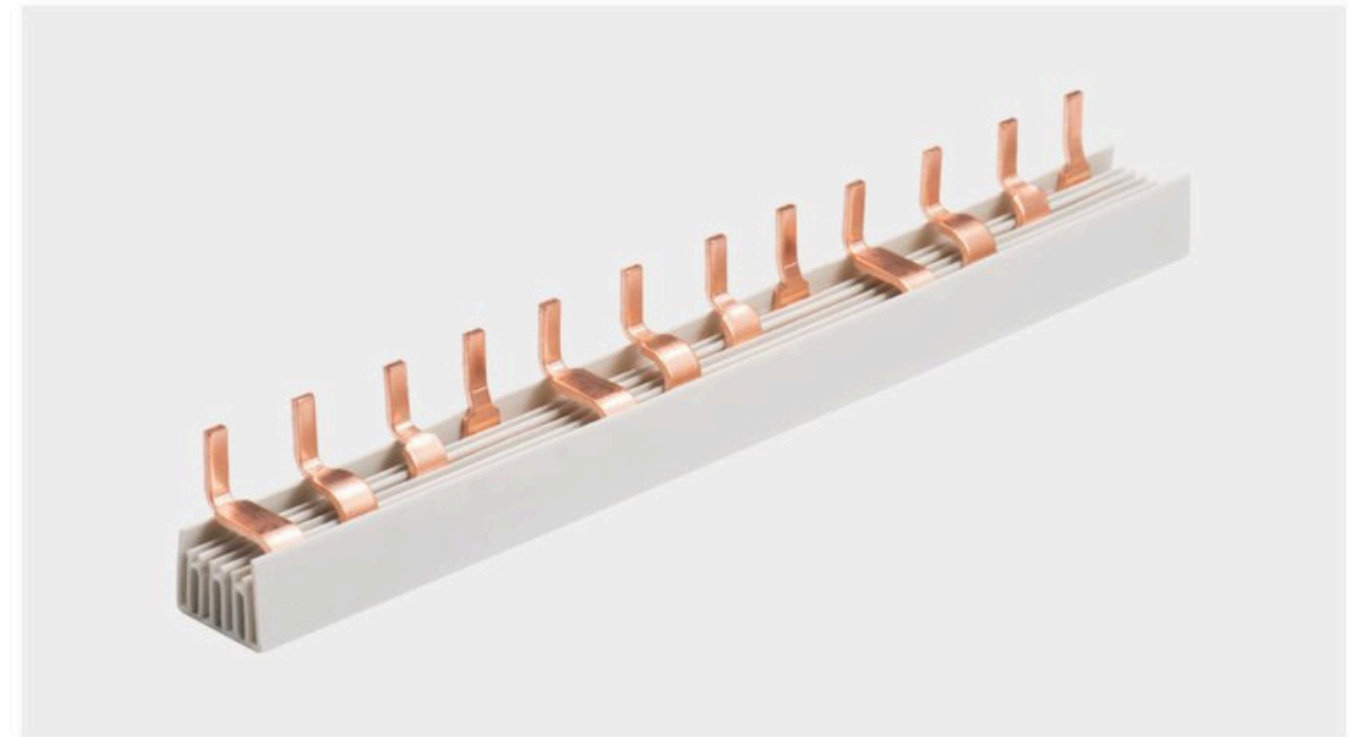

Description	Article No.	A Cross Section	B Distance (mm)	C Width of Pin(mm)	D Length of Pin(mm)	E Modules	F Length (mm)	G Reference Current
S-4L-210/8	KS041208	8mm ²	17.8	4	12.5	12	210	50A
S-4L-210/10	KS041210	10mm ²	17.8	4	12.5	12	210	63A
S-4L-210/13	KS041213	13mm ²	17.8	4	12.5	12	210	70A
S-4L-210/16	KS041216	16mm ²	17.8	4	12.5	12	210	80A
S-4L-1016/8	KS045608	8mm ²	17.8	4	12.5	56	1016	50A
S-4L-1016/10	KS045610	10mm ²	17.8	4	12.5	56	1016	63A
S-4L-1016/13	KS045613	13mm ²	17.8	4	12.5	56	1016	70A
S-4L-1016/16	KS045616	16mm ²	17.8	4	12.5	56	1016	80A

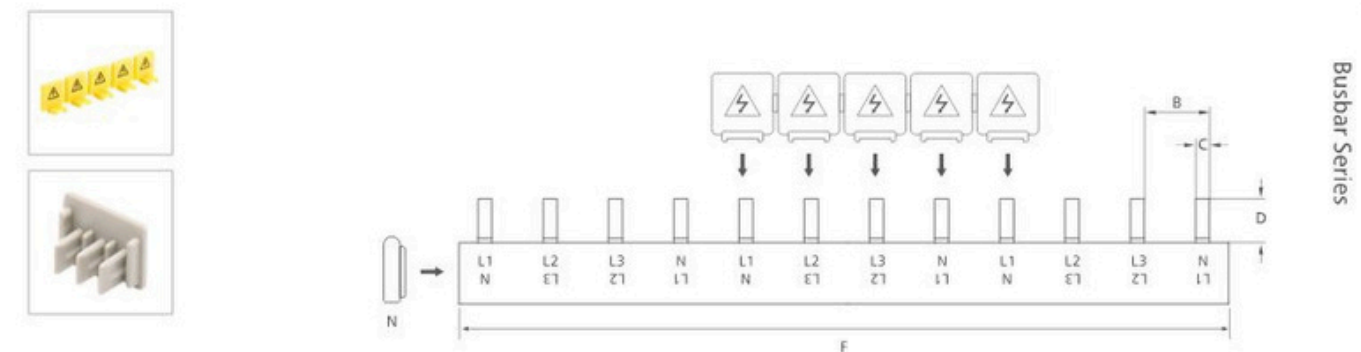

Pork type, 3L+3N busbars

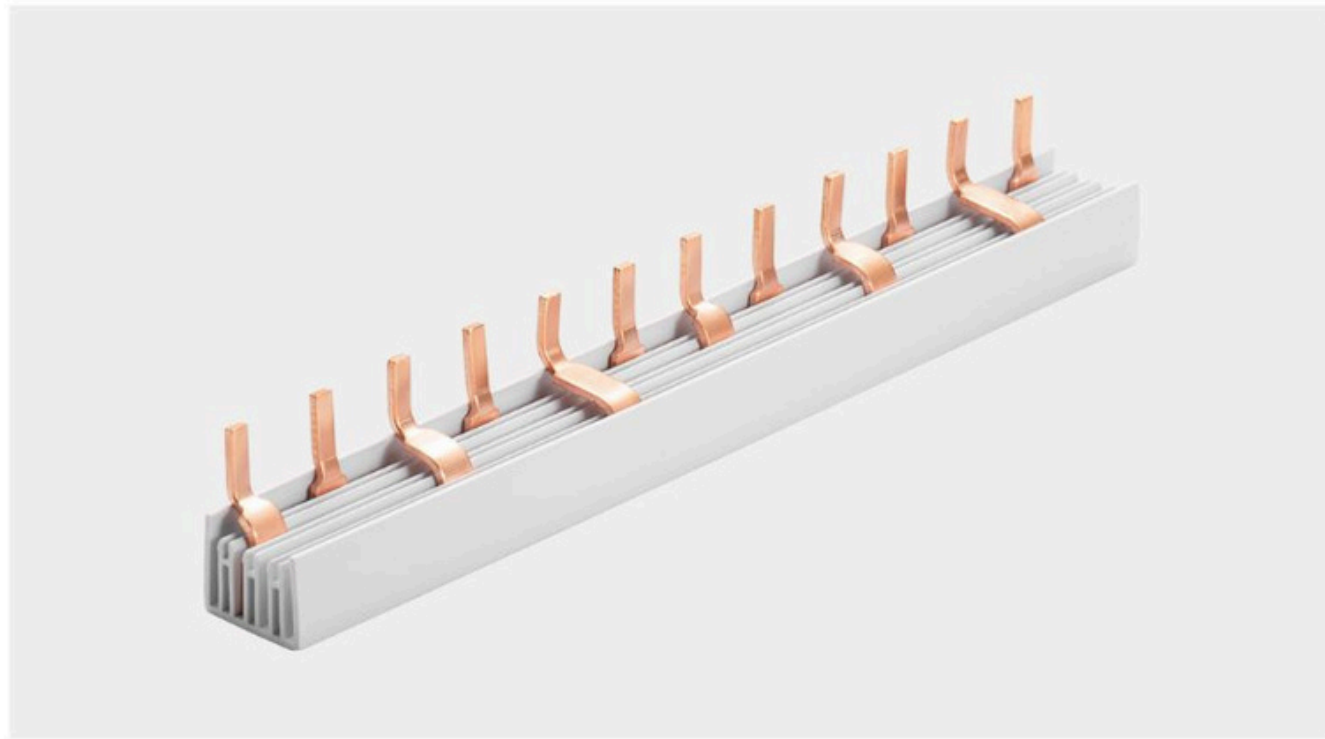

Description	Article No.	A Cross Section	B Distance (mm)	C Width of Pin(mm)	D Length of Pin(mm)	E Modules	F Length (mm)	G Reference Current
S-3L+3N-210/8C	KS051208	8mm ²	17.8	4	11.5	12	210	50A
S-3L+3N-210/10C	KS051210	10mm ²	17.8	4	11.5	12	210	63A
S-3L+3N-210/13C	KS051213	13mm ²	17.8	4	11.5	12	210	70A
S-3L+3N-210/16C	KS051216	16mm ²	17.8	4	11.5	12	210	80A
S-3L+3N-1000/8C	KS055408	8mm ²	17.8	4	11.5	54	1000	50A
S-3L+3N-1000/10C	KS055410	10mm ²	17.8	4	11.5	54	1000	63A
S-3L+3N-1000/13C	KS055413	13mm ²	17.8	4	11.5	54	1000	70A
S-3L+3N-1000/16C	KS055416	16mm ²	17.8	4	11.5	54	1000	80A

Pin type, 2-phase closed busbars

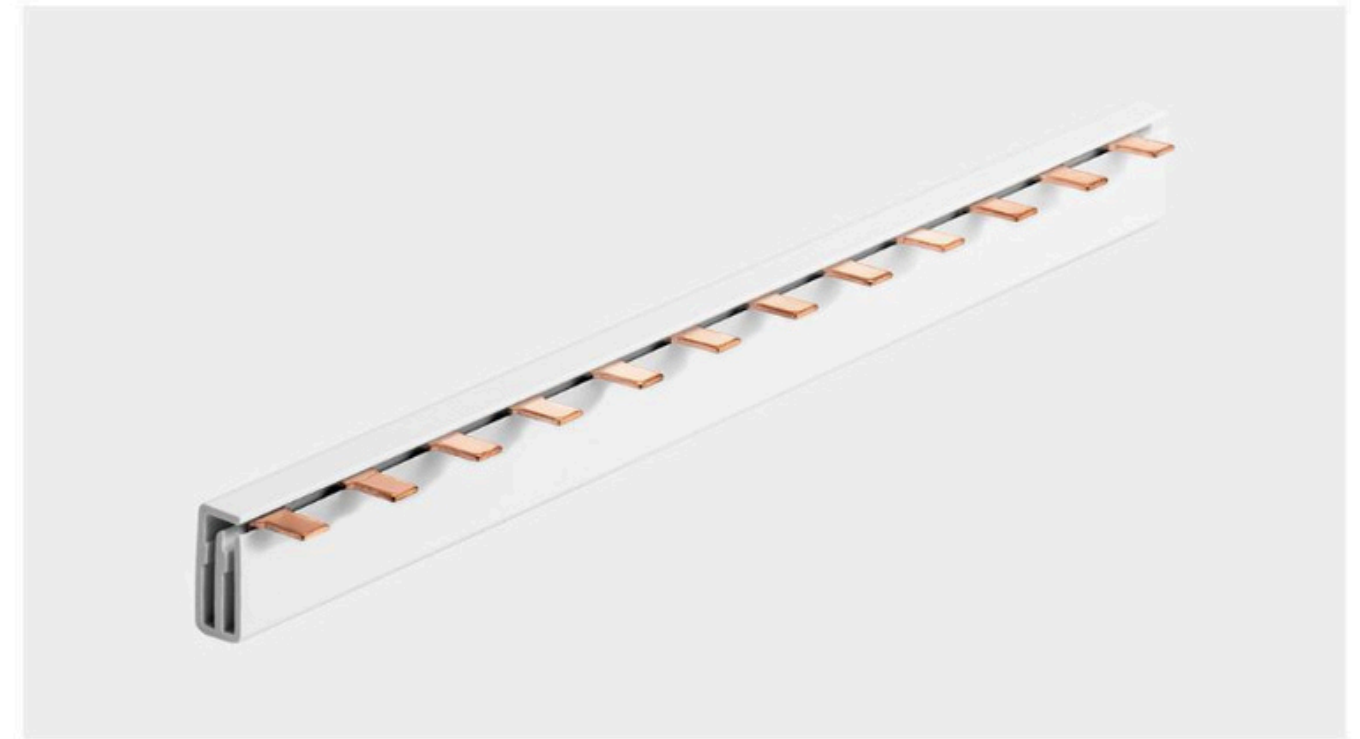

Description	Article No.	A Cross Section	B Distance (mm)	C Width of Pin(mm)	D Length of Pin(mm)	E Modules	F Length (mm)	G Reference Current
P-2L-210/8D	KP021208D	8mm ²	17.8	4	11.5	12	210	50A
P-2L-210/10D	KP021210D	10mm ²	17.8	4	11.5	12	210	63A
P-2L-210/13D	KP021213D	13mm ²	17.8	4	11.5	12	210	70A
P-2L-210/16D	KP021216D	16mm ²	17.8	4	11.5	12	210	80A
P-2L-1000/8D	KP025408D	8mm ²	17.8	4	11.5	54	1000	50A
P-2L-1000/10D	KP025410D	10mm ²	17.8	4	11.5	54	1000	63A
P-2L-1000/13D	KP025413D	13mm ²	17.8	4	11.5	54	1000	70A
P-2L-1000/16D	KP025416D	16mm ²	17.8	4	11.5	54	1000	80A
P-2L-1016/8D	KP025608D	8mm ²	17.8	4	11.5	56	1016	50A
P-2L-1016/10D	KP025610D	10mm ²	17.8	4	11.5	56	1016	63A
P-2L-1016/13D	KP025613D	13mm ²	17.8	4	11.5	56	1016	70A
P-2L-1016/16D	KP025616D	16mm ²	17.8	4	11.5	56	1016	80A

Busbar Series

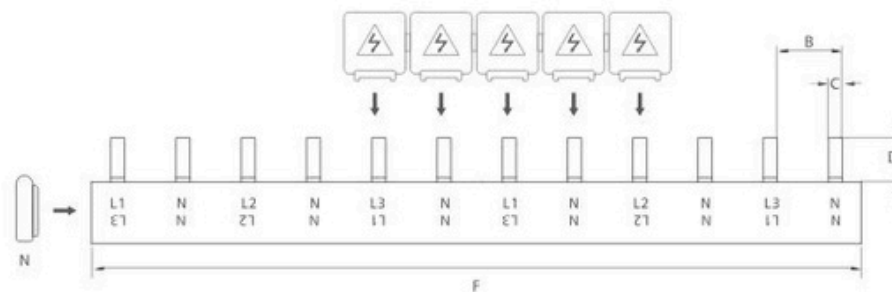

Busbar Series

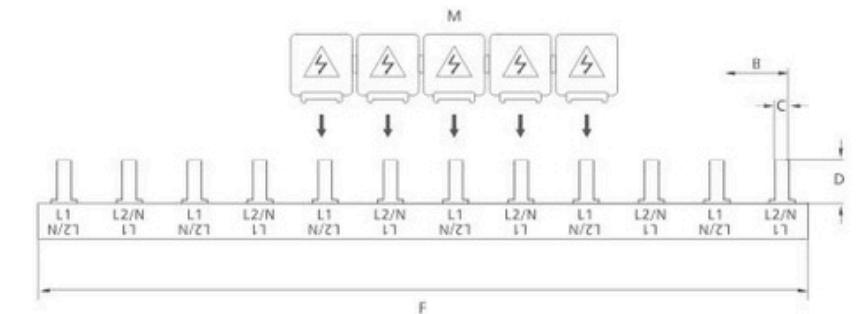

Pin type, 3-phase closed busbars

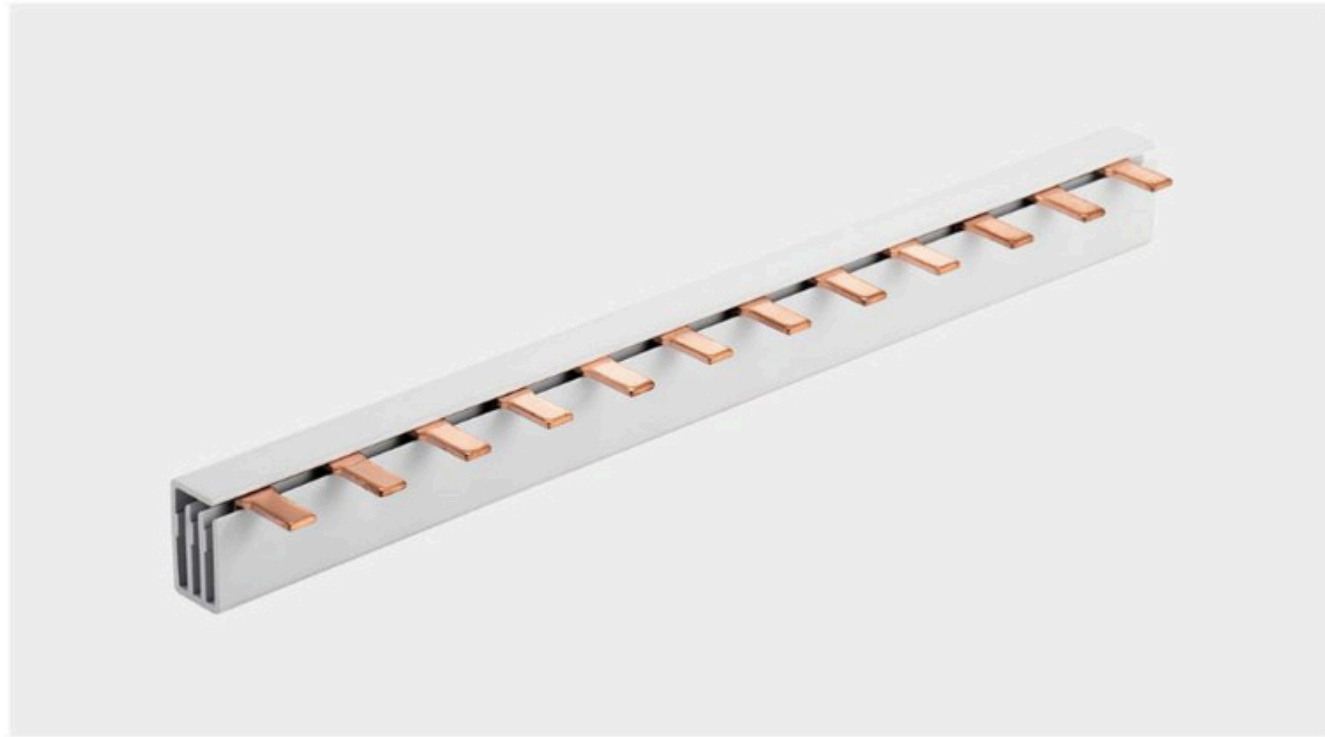

Description	Article No.	A Cross Section	B Distance (mm)	C Width of Pin(mm)	D Length of Pin(mm)	E Modules	F Length (mm)	G Reference Current
P-3L-210/8D	KP031208D	8mm ²	17.8	4	11.5	12	210	50A
P-3L-210/10D	KP031210D	10mm ²	17.8	4	11.5	12	210	63A
P-3L-210/13D	KP031213D	13mm ²	17.8	4	11.5	12	210	70A
P-3L-210/16D	KP031216D	16mm ²	17.8	4	11.5	12	210	80A
P-3L-1000/8D	KP035408D	8mm ²	17.8	4	11.5	54	1000	50A
P-3L-1000/10D	KP035410D	10mm ²	17.8	4	11.5	54	1000	63A
P-3L-1000/13D	KP035413D	13mm ²	17.8	4	11.5	54	1000	70A
P-3L-1000/16D	KP035416D	16mm ²	17.8	4	11.5	54	1000	80A
P-3L-1016/8D	KP035708D	8mm ²	17.8	4	11.5	57	1016	50A
P-3L-1016/10D	KP035710D	10mm ²	17.8	4	11.5	57	1016	63A
P-3L-1016/13D	KP035713D	13mm ²	17.8	4	11.5	57	1016	70A
P-3L-1016/16D	KP035716D	16mm ²	17.8	4	11.5	57	1016	80A

Fork type, 2 phase closed busbars(M6)

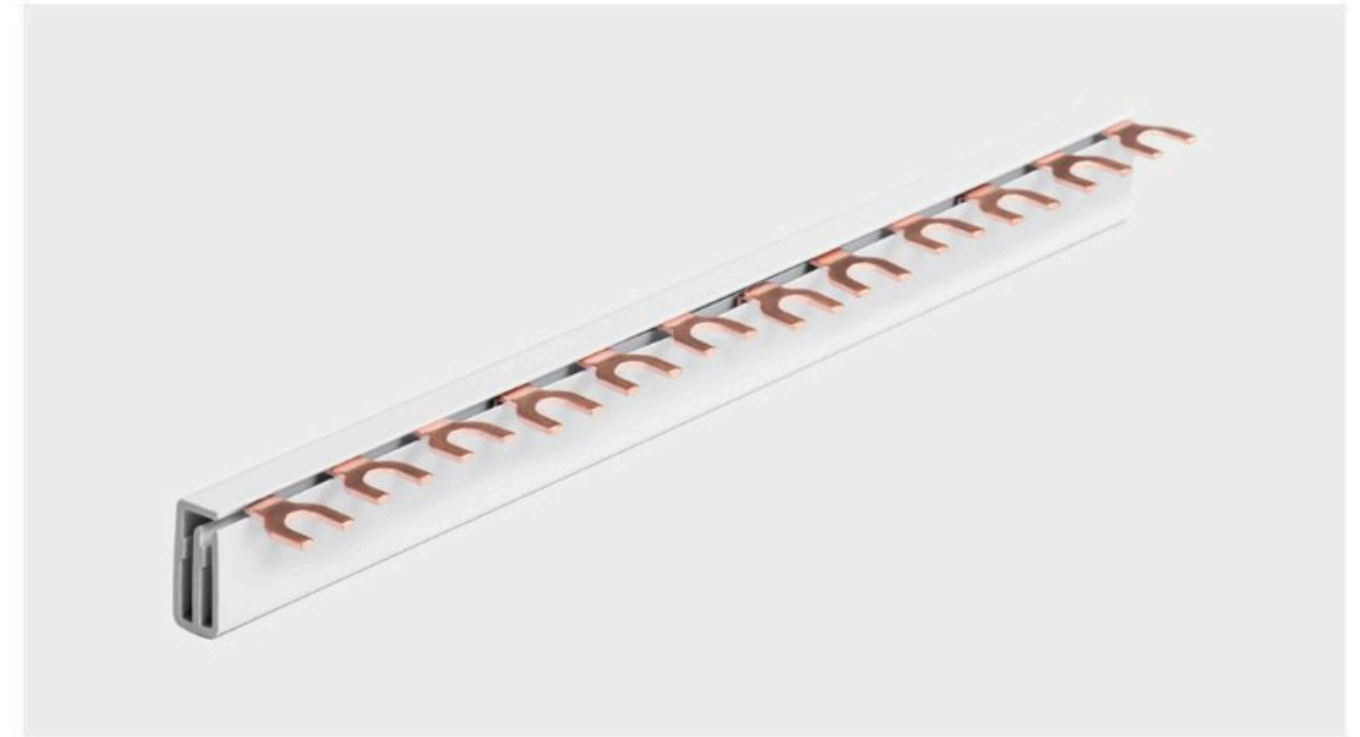

Description	Article No.	A Cross Section	B Distance (mm)	C Width of Fork(mm)	D Length of Fork(mm)	E Modules	F Length (mm)	G Reference Current
F-2L-210/8D	KF021208D	8mm ²	17.8	12	12	12	210	50A
F-2L-210/10D	KF021210D	10mm ²	17.8	12	12	12	210	63A
F-2L-210/13D	KF021213D	13mm ²	17.8	12	12	12	210	70A
F-2L-210/16D	KF021216D	16mm ²	17.8	12	12	12	210	80A
F-2L-1000/8D	KF025408D	8mm ²	17.8	12	12	54	1000	50A
F-2L-1000/10D	KF025410D	10mm ²	17.8	12	12	54	1000	63A
F-2L-1000/13D	KF025413D	13mm ²	17.8	12	12	54	1000	70A
F-2L-1000/16D	KF025416D	16mm ²	17.8	12	12	54	1000	80A
F-2L-1016/8D	KF025608D	8mm ²	17.8	12	12	56	1016	50A
F-2L-1016/10D	KF025610D	10mm ²	17.8	12	12	56	1016	63A
F-2L-1016/13D	KF025613D	13mm ²	17.8	12	12	56	1016	70A
F-2L-1016/16D	KF025616D	16mm ²	17.8	12	12	56	1016	80A

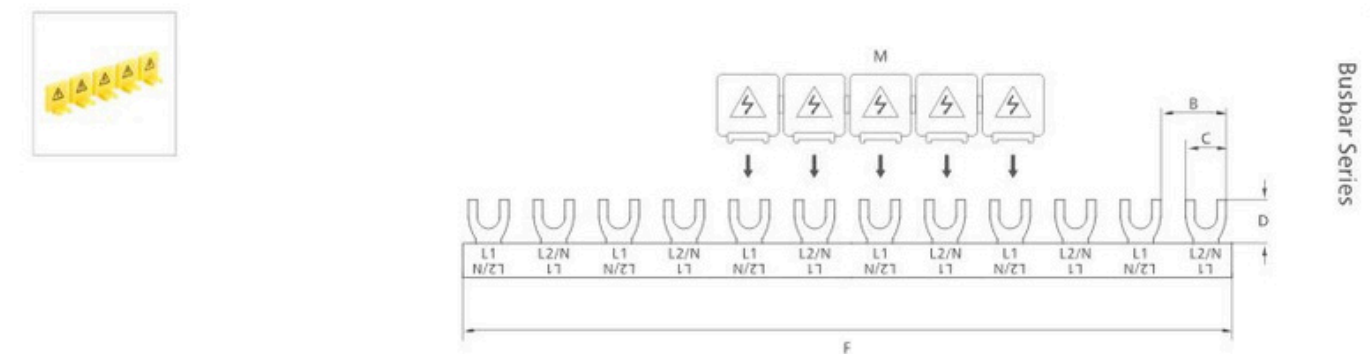
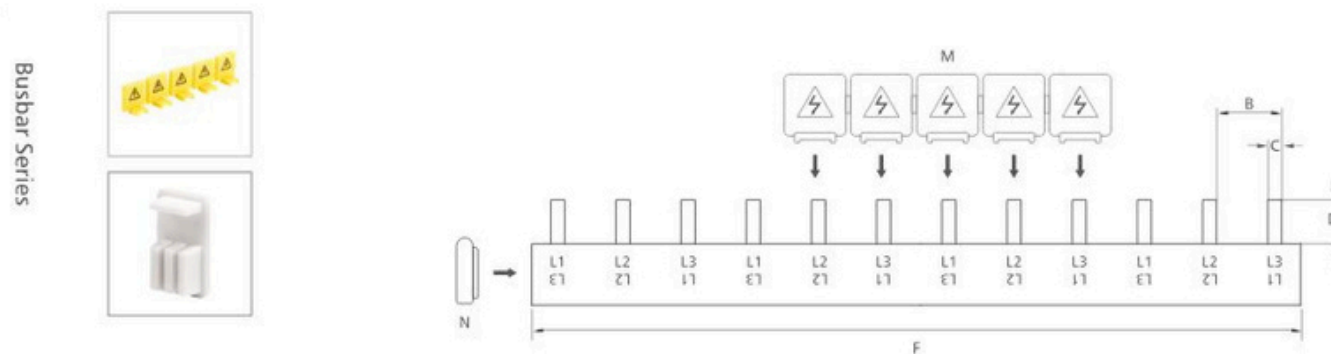

Fork type, 3 phased closed busbars (M6)

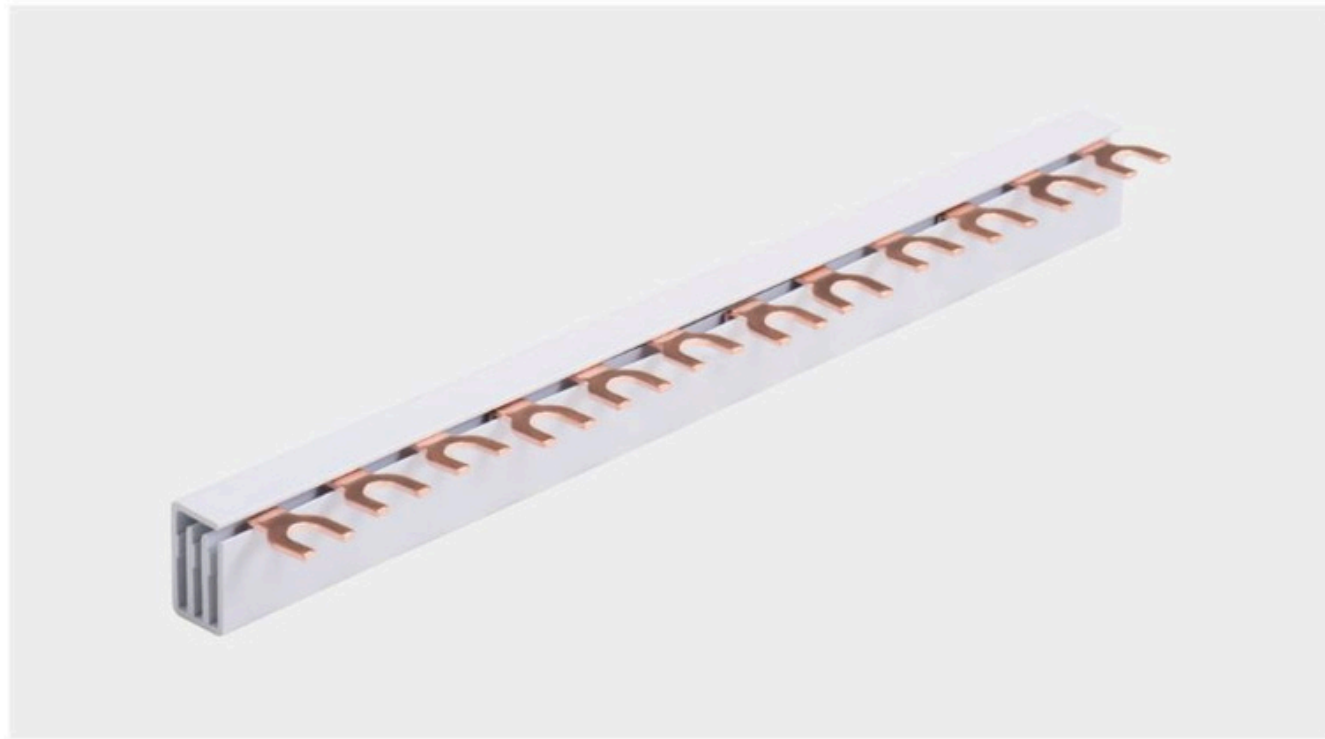

Description	Article No.	A Cross Section	B Distance (mm)	C Width of Fork (mm)	D Length of Fork (mm)	E Modules	F Length (mm)	G Reference Current
F-3L-210/8D	KF031208D	8mm ²	17.8	12	12	12	210	50A
F-3L-210/10D	KF031210D	10mm ²	17.8	12	12	12	210	63A
F-3L-210/13D	KF031213D	13mm ²	17.8	12	12	12	210	70A
F-3L-210/16D	KF031216D	16mm ²	17.8	12	12	12	210	80A
F-3L-1000/8D	KF035408D	8mm ²	17.8	12	12	54	1000	50A
F-3L-1000/10D	KF035410D	10mm ²	17.8	12	12	54	1000	63A
F-3L-1000/13D	KF035413D	13mm ²	17.8	12	12	54	1000	70A
F-3L-1000/16D	KF035416D	16mm ²	17.8	12	12	54	1000	80A
F-3L-1016/8D	KF035708D	8mm ²	17.8	12	12	57	1016	50A
F-3L-1016/10D	KF035710D	10mm ²	17.8	12	12	57	1016	63A
F-3L-1016/13D	KF035713D	13mm ²	17.8	12	12	57	1016	70A
F-3L-1016/16D	KF035716D	16mm ²	17.8	12	12	57	1016	80A

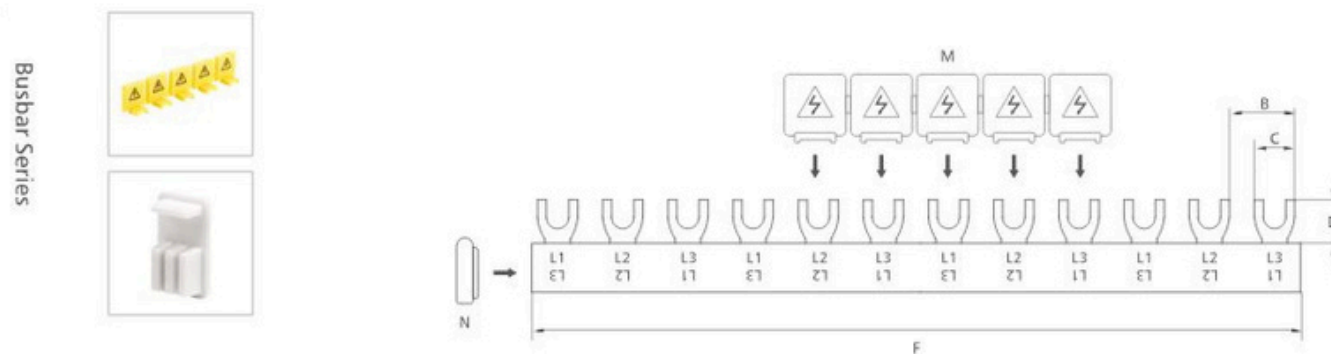

Pin type, 1-phase busbars

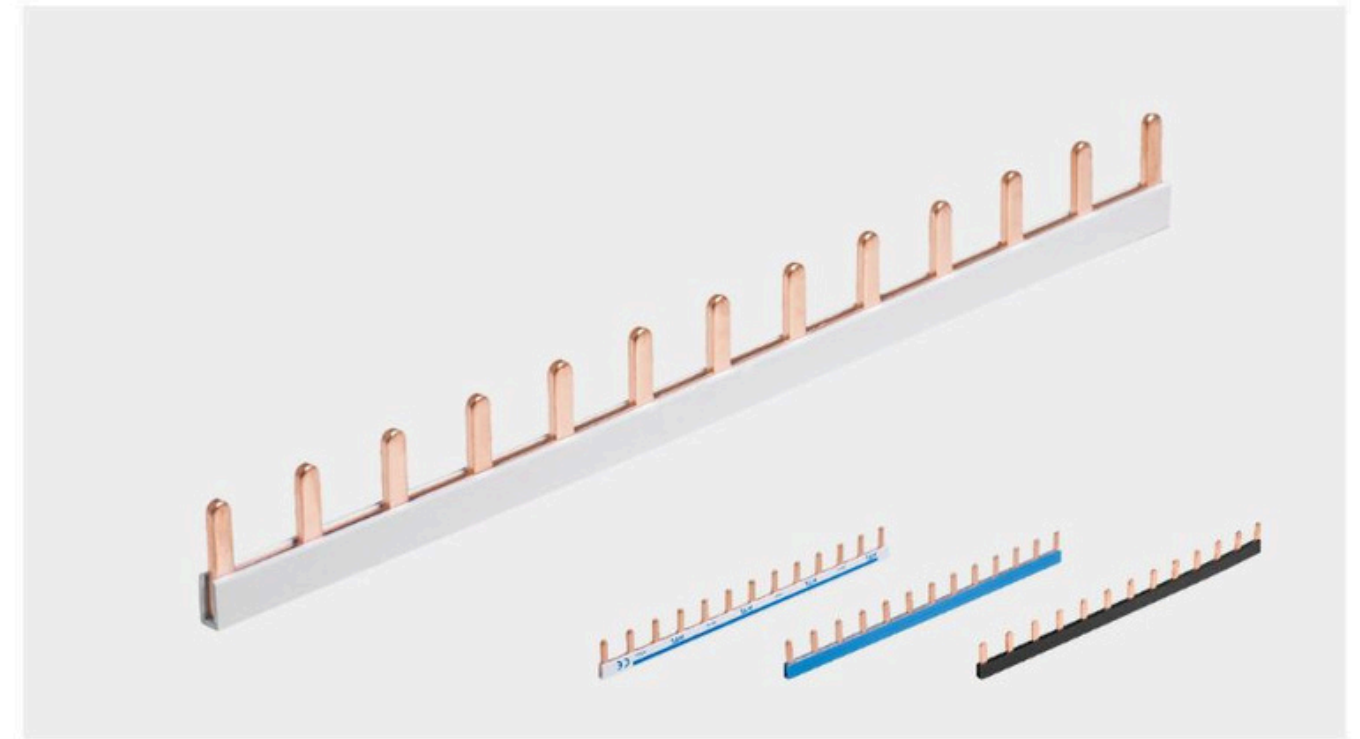

Description	Article No.	A Cross Section	B Distance (mm)	C Width of Pin (mm)	D Length of Pin (mm)	E Modules	F Length (mm)	G Reference Current
P-1L-225/10ISO	KP011310I	10mm ²	17.8	4	11.5	13	225	63A
P-1L-225/12ISO	KP011312I	12mm ²	17.8	4	11.5	13	225	70A
P-1L-225/13ISO	KP011314I	14mm ²	17.8	4	11.5	13	225	80A
P-1L-1000/10ISO	KP015410I	10mm ²	17.8	4	11.5	54	1000	63A
P-1L-1000/12ISO	KP015412I	12mm ²	17.8	4	11.5	54	1000	70A
P-1L-1000/14ISO	KP015414I	14mm ²	17.8	4	11.5	54	1000	80A

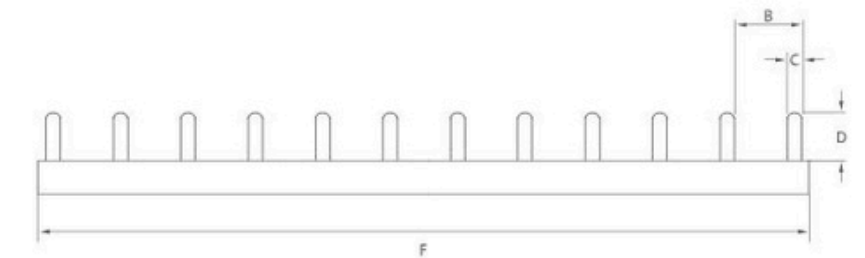

Pin type, 1P closed busbars

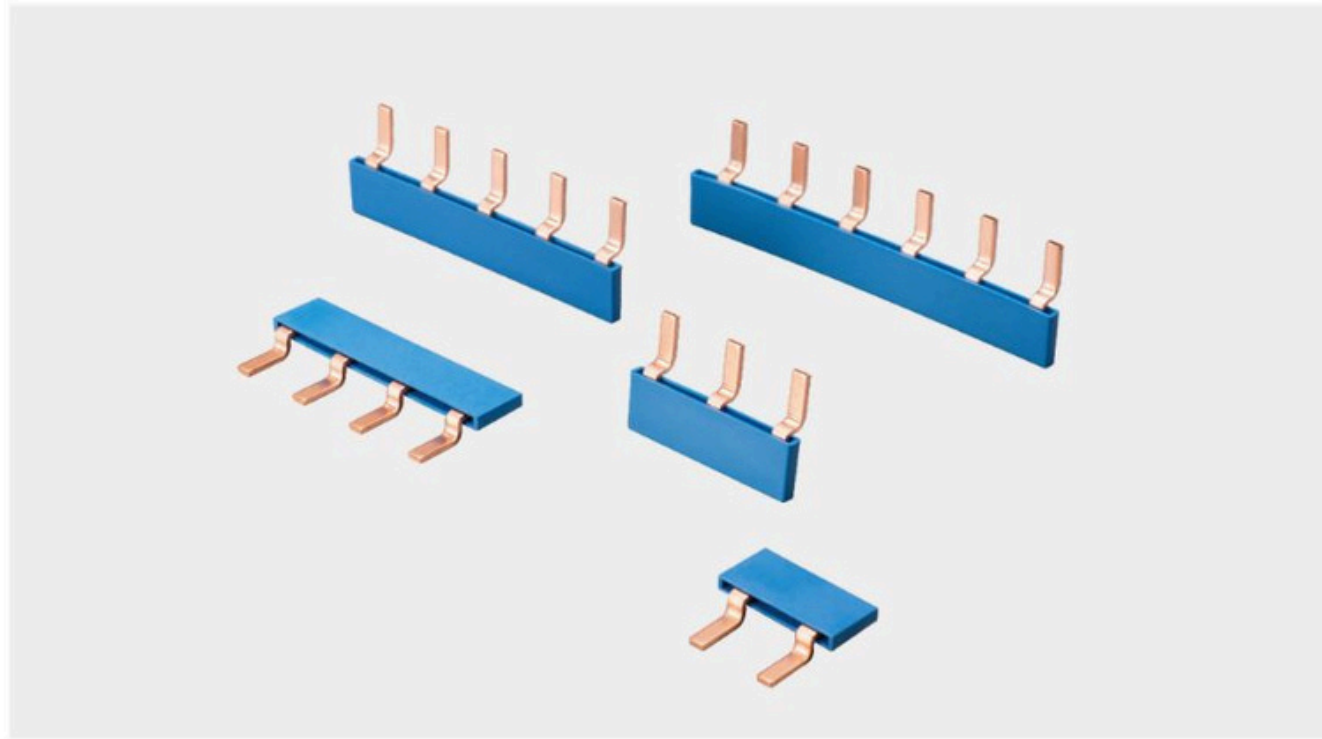

Description	Article No.	A Cross Section	B Distance(mm)	C Width of Pin(mm)	D Length of Pin(mm)	E Modules	F Length (mm)	G Reference Current
P-1L-30/10DB	KP010210DB	10mm ²	17.8	4	13.8	2	30	63A
P-1L-44/10DB	KP010310DB	10mm ²	17.8	4	13.8	3	44	63A
P-1L-64/10DB	KP010410DB	10mm ²	17.8	4	13.8	4	64	63A
P-1L-81/10DB	KP010510DB	10mm ²	17.8	4	13.8	5	81	63A
P-1L-103/10DB	KP010610DB	10mm ²	17.8	4	13.8	6	103	63A

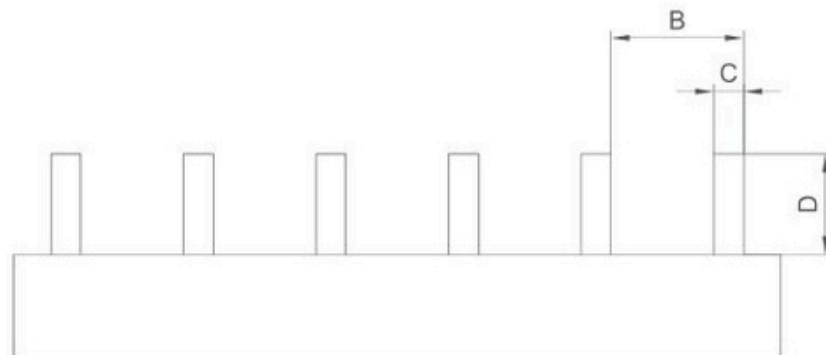

Busbar Series

Pin type, 1P closed busbars

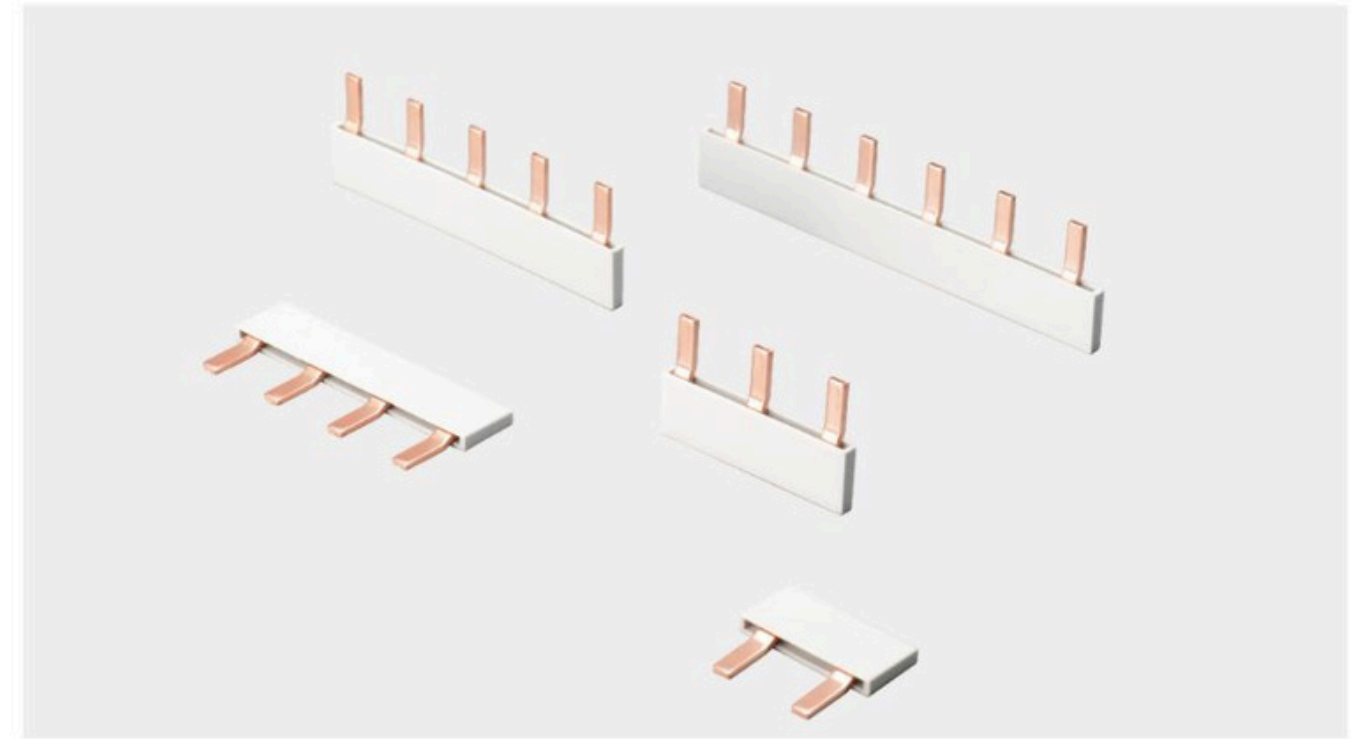

Description	Article No.	A Cross Section	B Distance (mm)	C Width of Pin(mm)	D Length of Pin(mm)	E Modules	F Length (mm)	G Reference Current
P-1L-30/10DA	KP010210DA	10mm ²	17.8	4	13.5	2	30	63A
P-1L-44/10DA	KP010310DA	10mm ²	17.8	4	13.5	3	44	63A
P-1L-64/10DA	KP010410DA	10mm ²	17.8	4	13.5	4	64	63A
P-1L-81/10DA	KP010510DA	10mm ²	17.8	4	13.5	5	81	63A
P-1L-103/10DA	KP010610DA	10mm ²	17.8	4	13.5	6	103	63A

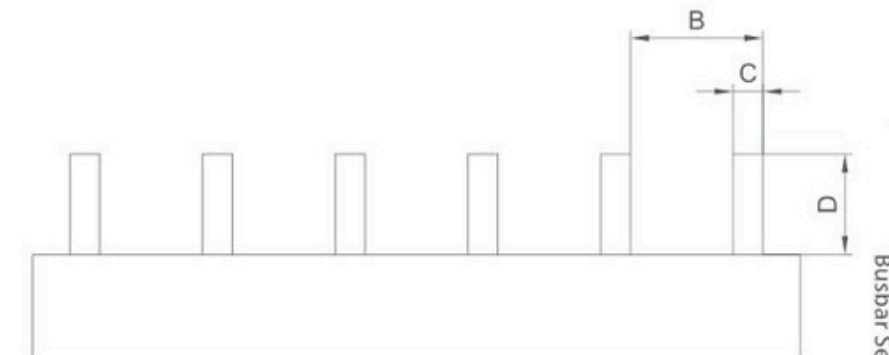

Busbar Series

Customized busbars

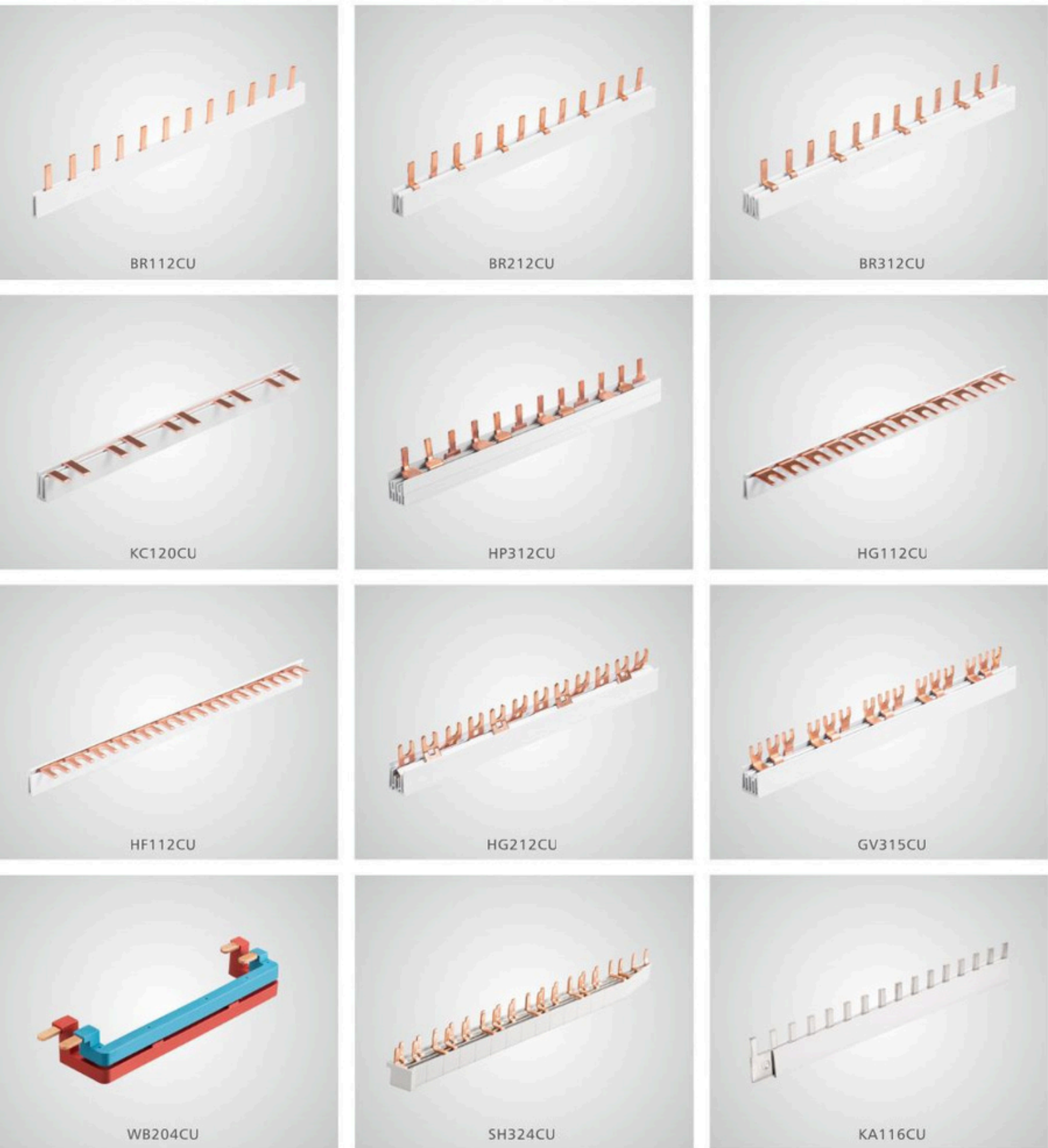

End caps

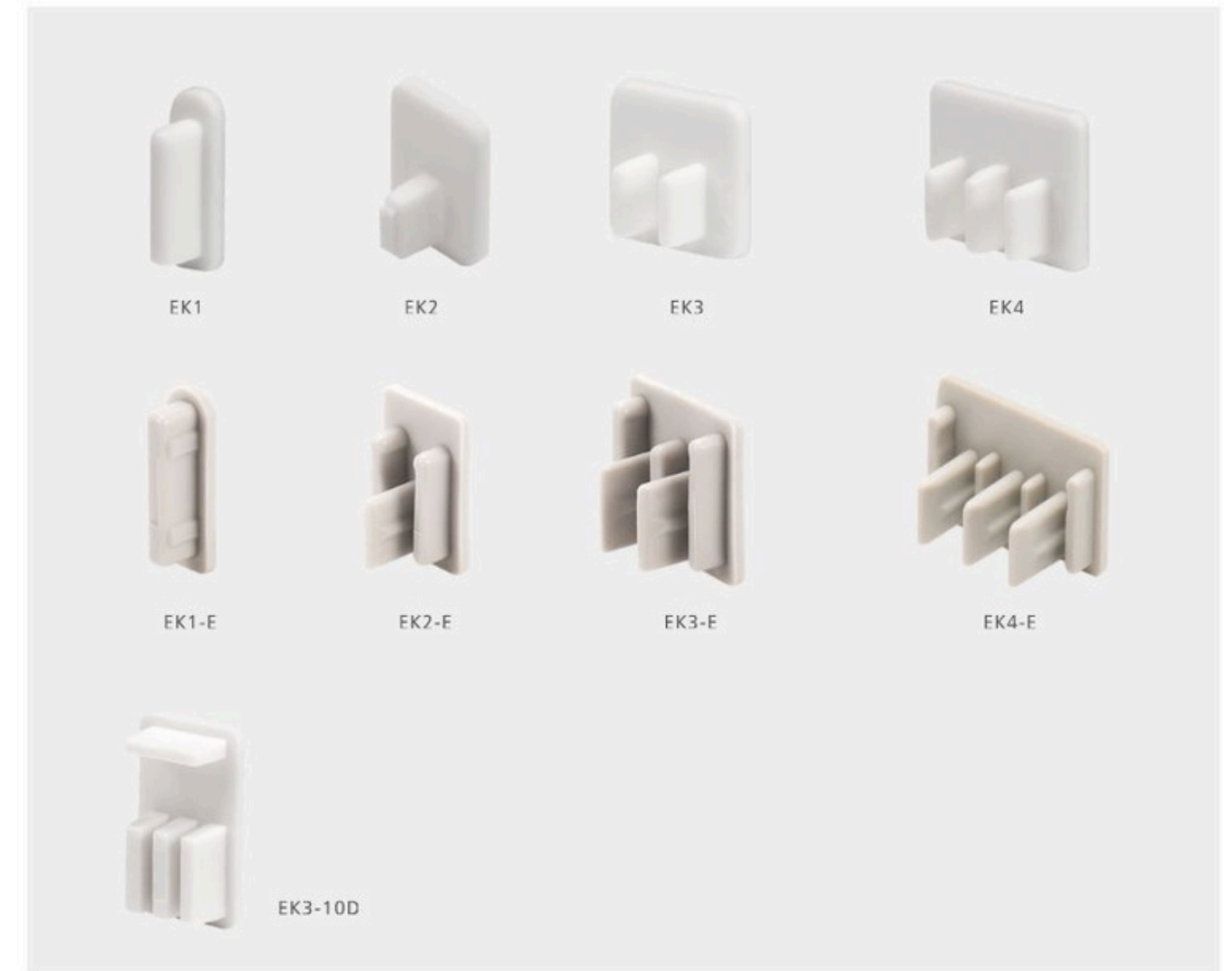

Description	Pole	Article No.
EK1-10	1P	EK110
EK1-16	1P	EK116
EK2-10/16	2P	EK21016
EK3-10/16	3P	EK31016
EK4-10/16	4P	EK41016

Description	Pole	Article No.
EK1-10/16E	1P	EK11016E
EK2-10E	2P	EK210E
EK2-16E	2P	EK216E
EK3-10E	3P	EK310E
EK3-16E	3P	EK316E
EK4-10E	4P	EK410E
EK4-16E	4P	EK416E

Description	Pole	Article No.
EK3-10D	3P	EK310D

02

Connectors Series

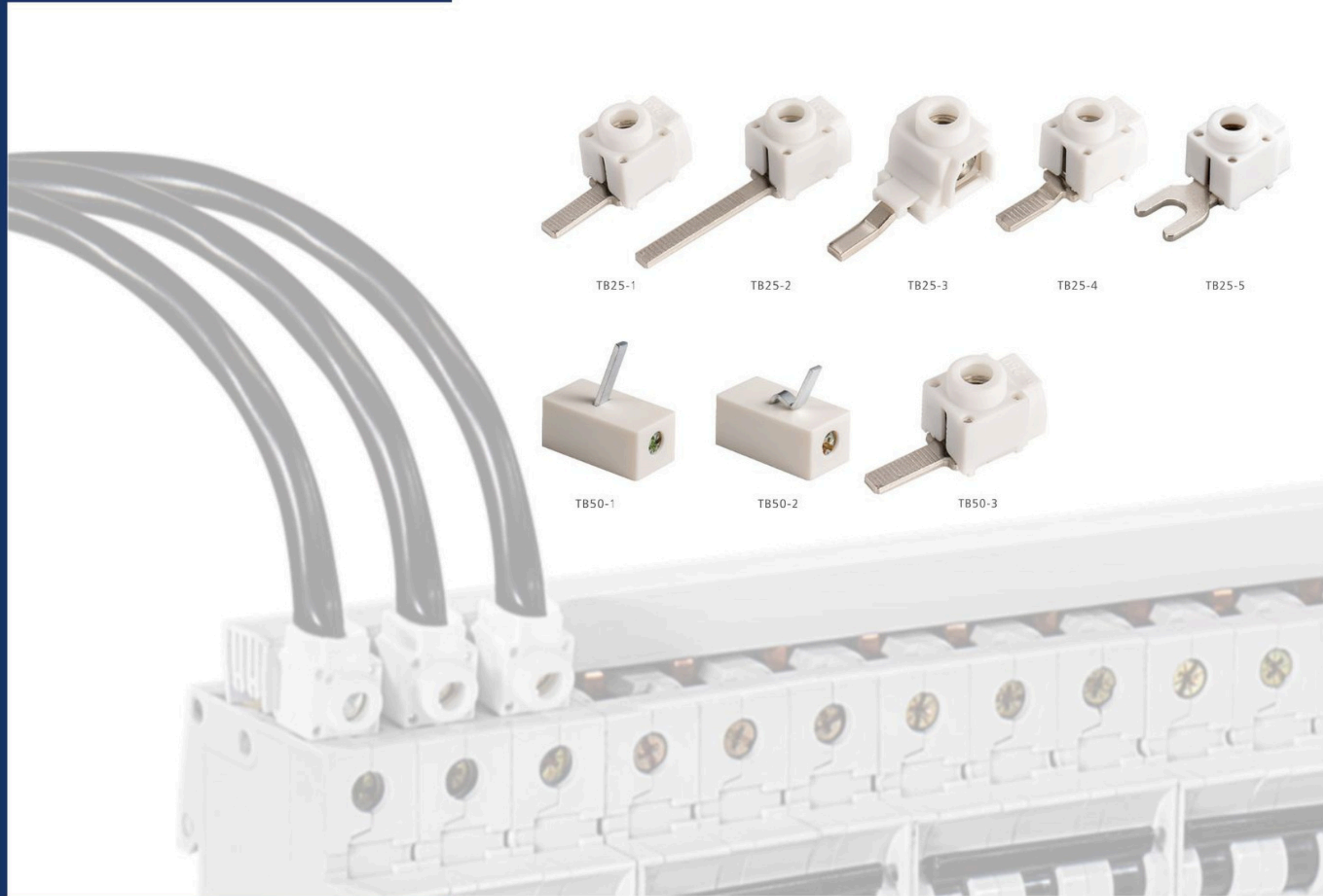

Article No.	Incoming	Dimension
TB25-1	25mm ²	32X13.2X17
TB25-2	25mm ²	49X13.2X17
TB25-3	25mm ²	34.5X17.5X18.2
TB25-4	25mm ²	32X13.2X17
TB25-5	25mm ²	32X13.2X17
TB50-1	50mm ²	35X17.5X34
TB50-2	50mm ²	35X17.5X34
TB50-3	50mm ²	32X16.2X36

03

5 Pole Protective cover

Protective Cover

Article No.	Description
COV-1	1-4 phase, 5 pole, 17.8mm
COV-2	1-4 phase, 5 pole, 17.8mm



Wiring Bridge

Description	Article No.	mm ²	Length (mm)	Color
2-pole	WB2-10	10mm ²	125	WB2-10 ■
	WB2-16	16mm ²	140	WB2-16B ■
3-pole	WB3-10	10mm ²	125	WB3-10 ■
	WB3-16	16mm ²	140	WB3-16B ■
4-pole	WB4-10	10mm ²	125	WB4-10 ■
	WB4-16	16mm ²	140	WB4-16B ■



Pan assembly busbar

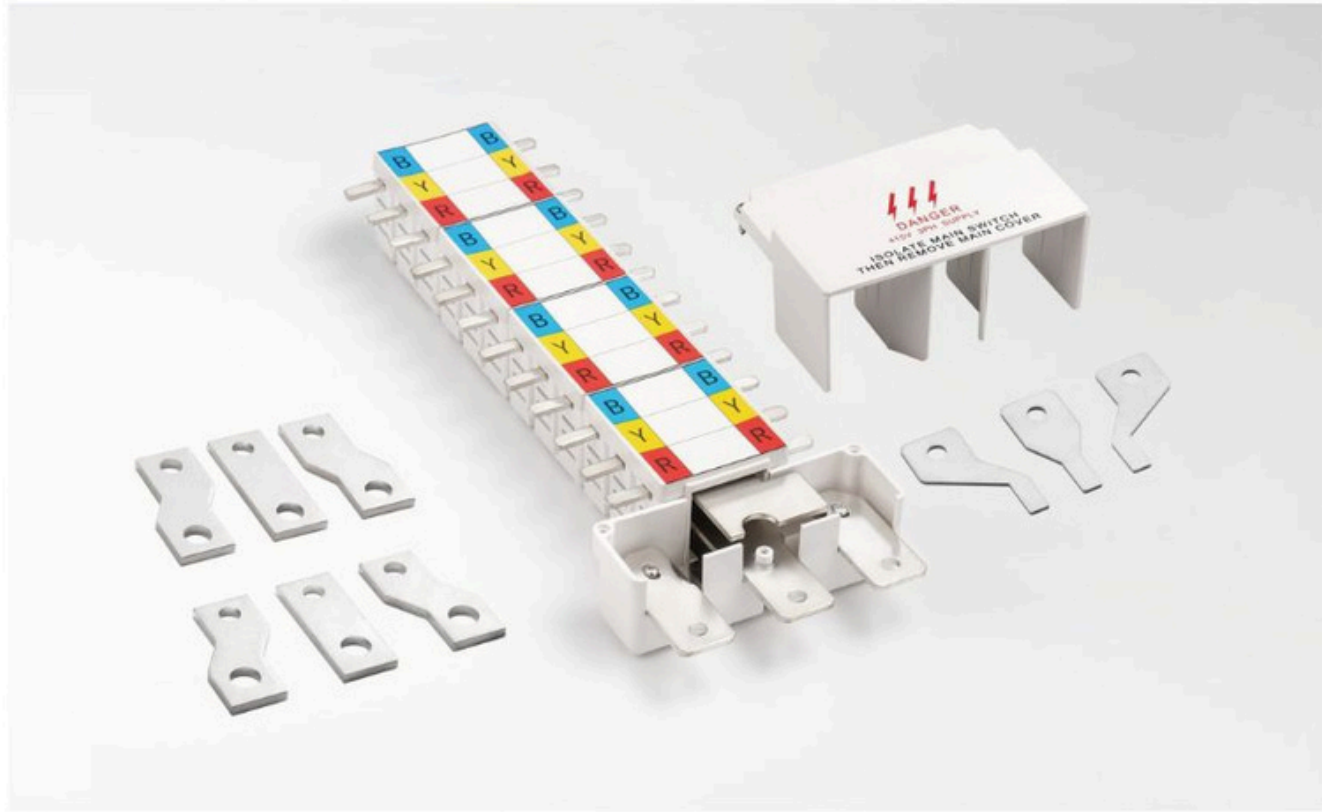

Model	Connect Size(mm) Thickness x Width	Outline Size(mm) Thickness x Width	Busbar Size(mm) Length x Width x Height
KP-125A/12W	2X5	2X20	180X49X46
KP-125A/18W	2X5	2X20	234X49X46
KP-125A/24W	2X5	2X20	288X49X46
KP-125A/30W	2X5	2X20	342X49X46
KP-125A/36W	2X5	2X20	396X49X46
KP-125A/42W	2X5	2X20	450X49X46
KP-125A/48W	2X5	2X20	504X49X46
KP-125A/54W	2X5	2X20	588X49X46
KP-125A/60W	2X5	2X20	612X49X46
KP-250A/12W	3X5	3X20	180X49X46
KP-250A/18W	3X5	3X20	234X49X46
KP-250A/24W	3X5	3X20	288X49X46
KP-250A/30W	3X5	3X20	342X49X46
KP-250A/36W	3X5	3X20	396X49X46
KP-250A/42W	3X5	3X20	450X49X46
KP-250A/48W	3X5	3X20	504X49X46
KP-250A/54W	3X5	3X20	588X49X46
KP-250A/60W	3X5	3X20	612X49X46

Copper Bar



Article No.	Dimension(mm)	Qty. / Ctns	Dimension(cm)
KB320125	3X20X125	120	34X22X18
KB320160	3X20X160	100	34X22X18
KB440180	4X40X180	50	42X21.5X14
KB435180	4X35X180	50	42X21.5X14
KB440200	4X40X200	50	42X21.5X14
KB440250	4X40X250	50	50X26.5X14
KB440300	4X40X300	40	42X31.5X14
KB440400	4X40X400	30	42X29.5X14
KB440500	4X40X500	20	52X21X14