



# PRESSURE CONTROL



LEFOO was founded in 2000, has been developed to be a integrated manufacturing enterprises of R&D, manufacturing, and sales. LEFOO group has 3 branch companies and divisions which include LEFOO Industrial Co.,Ltd, LEFOO Controls Co., Ltd, LEFOO Sensing Technology Co., Ltd,. LEFOO is committed to become the leading and world-class enterprise in R & D and manufacturing, to supply professional mechanical structure controls , electronic digital sensing controls, micro pumps, which can be widely used in environmental control , mechanical equipment, intelligent equipment, home appliances , medical , power, Internet of things , data center, water treatment, water purification, and other industrial fields.

LEFOO has passed ISO9001, ISO16949, ISO45001 , ISO 14001 management system certifications and CE, 3C, UL, CSA, RoHS , and safety certifications by authoritative TUV and SGS, with more than 130 patents in total. Over the past 20 years, LEFOO's market throughout more than 80 countries and regions in North America, Europe, Asia, South America, Africa , Australia. As a professional and trustworthy supplier , LEFOO has cooperated and established strategic partnership with many great companies and world famous brand.



# Pressure Switch

- 01 **LF08**  
Small multi-purpose pressure switch,0.2~45bar
- 02 **LF08A**  
High current pressure switch,0.2~45bar
- 03 **LF08D**  
Small multi-purpose pressure switch,60~250bar
- 04 **LF08E**  
Pressure switch for water purifier
- 05 **LF08H**  
Small multi-purpose pressure switch
- 06 **LF08M**  
Small multi-purpose pressure switch
- 07 **LF08V**  
Small vacuum pressure switch,-0.5~-0.8bar
- 08 **LF10**  
Air compressor pressure switch,25~200Psi
- 09 **LF10-L**  
Air compressor pressure switch,30~175Psi
- 10 **LF10-W**  
Pump pressure switch,15~150Psi
- 11 **LF12**  
Air Pressure Switches
- 12 **LF15**  
Pressure Switch
- 13 **LF16**  
Pump pressure switch,20~100Psi
- 14 **LF17**  
Air compressor pressure switch,15~500Psi
- 15 **LF17-W**  
Pump pressure switch,14~250Psi
- 16 **LF18**  
Air compressor and pump pressure switch ,1.0~16.0bar
- 17 **LF19**  
Air compressor and pump pressure switch,2.5~12.5bar
- 18 **LFPC-1**  
Automatic water pump controller
- 19 **LF20**  
Extended duty pressure switch,0.5~150Psi
- 20 **LF20-H**  
Ultra duty pressure switch,10~400Psi
- 21 **LF20-V**  
Vacuum pressure switch,1.1~22in/Hg
- 22 **LF25**  
Steam pressure switch,0.2~9.0bar
- 23 **LF30**  
Air differential pressure switch,0.4~8.0mbar
- 24 **LF31**  
Air differential pressure switch,0.15~34inW.C
- 25 **LF32**  
Air differential pressure switch,20~5000Pa
- 26 **LF35**  
Air differential pressure switch,0.3~30mbar
- 27 **LF37**  
Liquid level pressure switch,2~60 in W.C.
- 28 **LF40-01**  
Air actuated pressure switch,0.25~15psi
- 29 **LF40-B**  
Pressure switch
- 30 **LF40-C**  
Pressure switch
- 31 **LF55**  
Pressure switch for refrigeration system,-0.5~42bar
- 32 **LF55V**  
Vacuum pressure switch

# Pressure Switch and Refrigeration Parts

33	<b>LF55T</b> Thermostat
34	<b>LF58</b> Pressure switch for refrigeration system , -0.2~32bar
35	<b>LF5D</b> Oil differential pressure switch for refrigeration system,0.5~6.0bar
36	<b>LF56</b> Pressure switch
37	<b>LF52</b> Differential Pressure switch
38	<b>LF52A</b> Differential Pressure switch
39-40	<b>FS5 Series</b> Liquid flow switch
41-42	<b>FS20 Series</b> Liquid Flow Switch
43	<b>FS211</b> Electronic flow switch
44	<b>FS213</b> Electronic flow switch
45	<b>TS</b> Temperature controller
46	<b>TSD</b> Differential temperature controller
47	<b>TSH</b> Dual temperature controller
48	<b>LFS-01</b> Miniature pressure & vacuum switch, -800~-5mbar,10~600mbar
49	<b>LFS-02</b> Miniature pressure & vacuum switch , -800~-5mbar,5~800mbar
50	<b>LFS-03</b> Miniature pressure & vacuum switch , -800~-15mbar,15~2500mbar
51	<b>LF702</b> Pressure switch
52	<b>LF708</b> Pressure switch
53	<b>LF708A</b> Pressure switch
54	<b>LF727</b> Pressure switch
55	<b>LF727A</b> Pressure switch
56	<b>LF727B</b> Pressure switch
57	<b>LFB</b> Differential pressure gauge
59-60	<b>LFZ</b> Standard Rotary Actuator
61-62	<b>LFZ-Q</b> Fast Running Rotary Actuators
63	<b>LFZ-T</b> Spring Reset Damper Actuator
64	<b>LFZ-DQ</b> Electrical regulating ball valve
65-66	<b>LFSV-D</b> Solenoid Valve
67-67	<b>LFSV-K</b> Solenoid Valve
68-69	<b>LFFDF</b> Solenoid Valve
70	<b>LFBV</b> Ball Valve

## Refrigeration Parts

- 71 **LFSG**  
Sight Glass
- 72 **LFCV**  
Charging Valve
- 73 **LFTEV**  
Thermostatic Expansion Valves
- 74 **LFDBV**  
Discharge-Bypass Valves
- 75 **LFDCV**  
Magnetic check valve

## Differential Pressure Transmitter Series

- 76 **LFM108**  
Differential pressure transmitter, 0~10000Pa
- 77 **LFM11**  
Differential pressure transmitter, -10000~10000Pa
- 78 **LFM32**  
Differential pressure transmitter/controller, -10000~10000Pa
- 79 **LFM52**  
Differential pressure transmitter, -10000~10000Pa
- 80 **LFM53**  
Differential pressure transmitter, -100~100Pa
- 81 **LFM208**  
Residual pressure sensor, -100~100Pa

## Pressure Transmitter Series

- 82-83 **LFT700**  
Pressure transmitter
- 84-85 **LFT710**  
Differential pressure transmitter
- 86-87 **LFT710A**  
Single flange-mount remote pressure transmitter
- 88-89 **LFT710B**  
Double flange-mount remote pressure transmitter
- 90 **LFT2000**  
General type pressure transmitter, -1~0...600bar
- 91 **LFT2800**  
Pressure transmitter, -100kPa...0~1kPa...60MPa
- 92 **LFT2010**  
High accuracy pressure transmitter, 0~0.1...-4MPa
- 93 **LFT2020**  
Sanitary flat film pressure transmitter, -100kPa...0~10kPa...7MPa
- 94 **LFT2030**  
High temperature resistant pressure transmitter
- 95 **LFT2050**  
Differential pressure transmitter, 0~10kPa...3.5MPa
- 96 **LFT2060**  
Refrigeration pressure transmitter, 0~50Bar
- 97 **LFT2600**  
Refrigeration pressure transmitter, 0~50Bar
- 98 **LFT2700**  
Flat film pressure transmitter, -100kPa...0~20kPa...35MPa
- 99 **LFT3000**  
Throw-in type liquid level pressure transmitter, 0~0.5...200mH<sub>2</sub>O
- 100 **LFT3100**  
Temperature pressure integrated transmitter, 0~10kPa...70MPa
- 101 **LFT3200**  
Temperature and liquid level integrated transmitter, 0~1...200mH<sub>2</sub>O
- 102 **LFT6100**  
Digital pressure gauge, -100kPa...0~100kPa...60MPa
- 103 **LFT6200**  
Digital pressure gauge, -100kPa...0~10kPa...60MPa

## Pressure Transmitter Series

- 104 **LFT6700**  
Pressure transmitter,0 ~ 10...60MPa
- 105 **LFT6800**  
Digital display pressure transmitter,-100kPa...0~10kPa...60MPa
- 106 **LFT221**  
Water pressure transmitter,0 ~ 1MPa

## Digital Pressure Switch Series

- 107 **LFDS10**  
Digital pressure switch ,-100~1000kPa
- 108 **LFDS62**  
Digital pressure switch,0 ~ 16Bar
- 109 **LFDS63**  
Digital pressure switch
- 110 **LFDS65**  
Digital pressure switch

## Environmental Testing Series

- 111 **LFW10**  
Temperature transmitter
- 112 **LFH10**  
Temperature and humidity transmitter
- 113 **LFH10A**  
Temperature and humidity transmitter
- 114 **LFH30**  
Temperature and humidity transmitter
- 115 **LFH51**  
Probe type temperature and humidity transmitter
- 116 **LFH52**  
Outdoor temperature and humidity transmitter
- 117 **LFH20**  
Indoor temperature and humidity transmitter
- 118 **LFH60**  
Magnetic temperature and humidity transmitter

## Gas Detection Series

- 119 **LFG101**  
Wall mounted carbon monoxide transmitter
- 120 **LFG201**  
Wall mounted carbon dioxide transmitter
- 121 **LFG202**  
Ducted carbon dioxide transmitter
- 122 **LFG203**  
Indoor carbon dioxide transmitter

## Wind Speed Transmitter Series

- 123 **LFS10**  
Air velocity transmitter

## Solenoid Valve

- 124 **SVD20**  
Inlet Solenoid Valve
- 125 **LFV18**  
Cold Water Inlet Solenoid Valve
- 126 **LFV19**  
Cold Water Inlet Solenoid Valve
- 127 **LF42**  
Water dispensers high and low pressure switch
- 128 **LFSV20-B**  
Drainage Solenoid Valve

# LF08

## Small multi-purpose Pressure switch

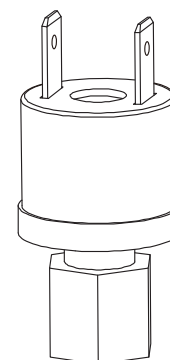
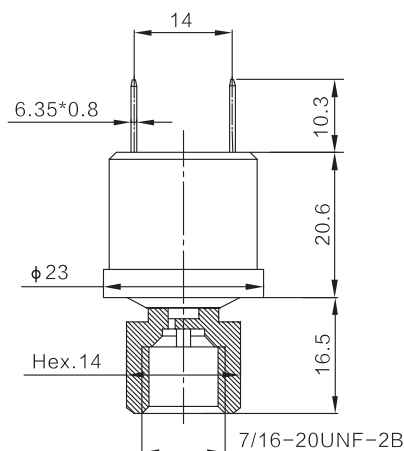

Dimension in : mm

The LF08 switches are fixed set point, factory calibrated pressure switches. It is automatic reset, and can be Normally open or normally close contacts. All metallic wetted components make the LF08 switch compatible with a multitude of chemicals in liquid or gas form. It is offered numerous types of electrical terminations from different size and style push on terminals to wire leads with an array of standard industry connectors. In house machining capabilities allows Lefoo to offer a wide variety of pressure fitting from different thread types and sizes to units with internal deflator and copper tubing for sawing operations.

### LF08 Order Ref NO

LF08 -1 1 1 1 -145-175psi

A B C D

Pressure setting: Reset pressure 145psi

Action pressure 175psi

Number	Circuitry	Base Material	Connection	Electrical connections
1	A SPST-NC	B brass	C 1/8NPT	D 6.35×0.8
2	SPST-NO	plated steel	1/4NPT	4.8×0.8
3	SPDT	/	R1/8	18AWG Wire harness
4	/	/	R1/4	/
5	/	/	G1/8	/
6	/	/	G1/4	/
7	/	/	1/4 Copper tube	/
8	/	/	7/16UNF External thread	/
9	/	/	7/16UNF Internal thread	/
10	/	/	7/16UNF Internal thread+valve element	/

### Specification

MODEL	LF08		
Media	Air,Water,motor oils,transmission oils,Hydrocarbon Media,Refrigeration fluid		
Pressure Range/ Tolerance/ Proof Pressure	Action pressure	Tolerance	Proof Pressure
	0.2~6bar(low pressure)	±0.5bar	15bar
	6~10bar	±0.7bar	35bar
	11~20bar	±1bar	45bar
	21~30bar	±1.5bar	
	31~45bar	±1.5bar	
Burst Pressure	5000psi		
Operating Temperature Range	Environment temperature:low pressure:-30~65°C,High pressure:-35~120°C; Medium temperature:-50~120°C		
Switch Type	SPST(NC OR NO);SPDT		
Electric Rating	120Vac 6FLA,40.2LRA; 240Vac 4FLA,26LRA		120/240Vac 375VA;36Vdc 3A
Endurance	100000		
Connection	Please see the selection table (customizable)		
Electrical connections	6.35*0.8;4.8*0.8 ; Wire connection (can be customized length and electrical plug)		

Conversion:1bar=14.5psi 1MPa=10bar

# LF08A

High current  
Pressure switch

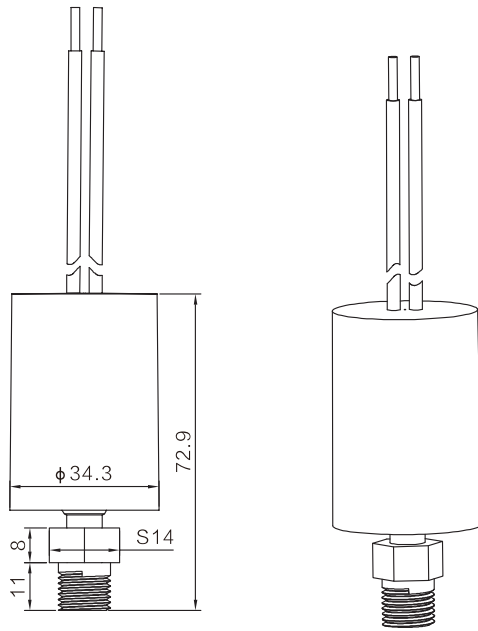

Dimension in : mm



The LF08A switches are fixed set point, factory calibrated pressure switches. It is automatic reset, and can be normally open or normally close contacts. All metallic wetted components make the LF08A switch compatible with a multitude of chemicals in liquid or gas form. It is offered numerous types of electrical terminations from different size and style push on terminals to wire leads with an array of standard industry connectors. In house machining capabilities allows Lefoo to offer a wide variety of pressure fitting from different thread types and sizes to units with internal deflator and copper tubing for sawing operations.

## LF08A Order Ref NO

LF08A-1 1 1 1 -145-175psi

**A B C D** Pressure setting:Reset pressure 145psi Action pressure 175psi

Number	Circuitry	Base Material	Connection	Electrical connections
1	<b>A</b> SPST-NC	<b>B</b> brass	<b>C</b> 1/8NPT	<b>D</b> 6.35×0.8
2	SPST-NO	plated steel	1/4NPT	16AWG Wire harness
3	SPDT	/	R1/8	14AWG Wire harness
4	/	/	R1/4	/
5	/	/	G1/8	/
6	/	/	G1/4	/
7	/	/	1/4 Copper tube	/
8	/	/	7/16UNF External thread	/
9	/	/	7/16UNF Internal thread	/
10	/	/	7/16UNF Internal thread+valve element	/

## Specification

MODEL	LF08A		
Media	Air,Water,motor oils,transmission oils,Hydrocarbon Media,Refrigeration fluid		
Pressure Range/ Tolerance/ Pressure value	Action pressure	Tolerance	Proof Pressure
	0.2~6bar(low pressure)	±0.5bar	15bar
	6~10bar	±0.7bar	35bar
	11~20bar	±1bar	45bar
	21~30bar	±1.5bar	
	31~45bar	±1.5bar	
Burst Pressure	5000psi		
Operating Temperature Range	Environment temperature:low pressure:-30~65°C ,High pressure:-35~120°C Medium temperature:-50~120°C		
Switch Type	SPST(NC OR NO);SPDT		
Electric Rating	120VAC,13FLA,65LRA;240VAC,10FLA,45LRA;480VAC,4FLA,24LRA 120/240VAC,480/720VA;28VDC,15AMP;24VAC,125VA		
Endurance	100000		
Connection	Please see the selection table (customizable)		
Electrical connections	6.35*0.8;Wire connection (can be customized length and electrical plug)		

# LF08D

Small multi-purpose pressure switch

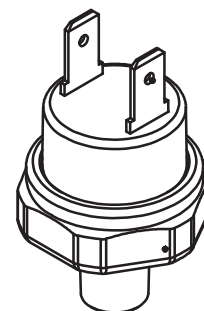
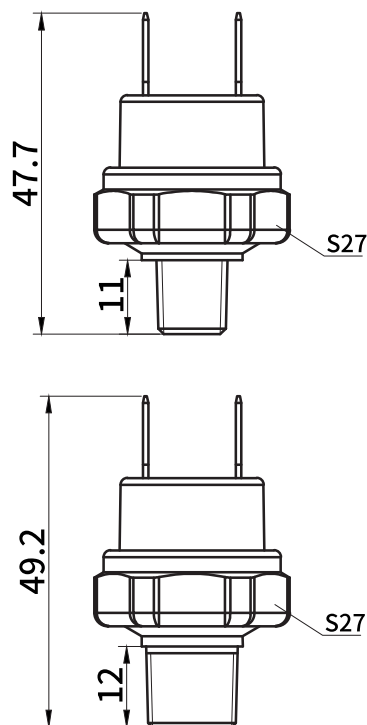
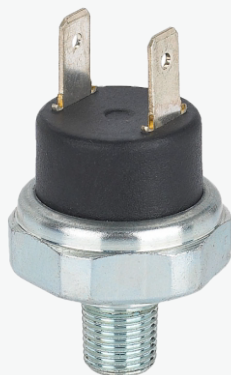

Dimension in:mm

LF08D series pressure switch is a switch with automatic reset design. With a wide pressure setting range, it can be applied to different requirements. It is used for air, water pressure control, electrical refrigeration equipment, indoor air conditioners or internal circuits of indoor cooling devices, domestic cooling systems, and internal circuits of long-distance outdoor condensing devices. Typical applications: High-pressure shutdownswitch/air-conditioning/freezingequipment.

## LF08D Order Ref NO

LF08D -1111 - 145-175psi

**A B C D** Pressure setting:Reset pressure(Note)  
Action pressure 175psi

Note: Products without deadband can be customized, that is, the action value is approximately the same as the reset value

Number	Circuitry	Base Material	Connection	Electrical connections
1	<b>A</b> SPST-NC	<b>B</b> Environmental protection zinc plating	<b>C</b> 1/8NPT	<b>D</b> 6.35×0.8
2	/	aluminium	1/4NPT	4.8×0.8
3	/	/	R1/8	/
4	/	/	R1/4	/
5	/	/	G1/8	/
6	/	/	G1/4	/

## Specification

Model	LF08D
Media	Air, Water, motor oils
Pressure Range	60~250PSI
Proof Pressure	20~50PSI
Tolerance	±5PSI
Proof Pressure	400PSI
Burst Pressure	800psi
Operating Temperature Range	-20~65°C
Switch Type	SPST(NC)
Electric Rating	220VAC,15FLA
Base material	Q235 Environmental protection zinc plating
Endurance	100000
Connection	Please see hte selection table (customizable)

Conversion:1bar=14.5psi 1MPa=10bar

# LF08E

Pressure switch for water purifier

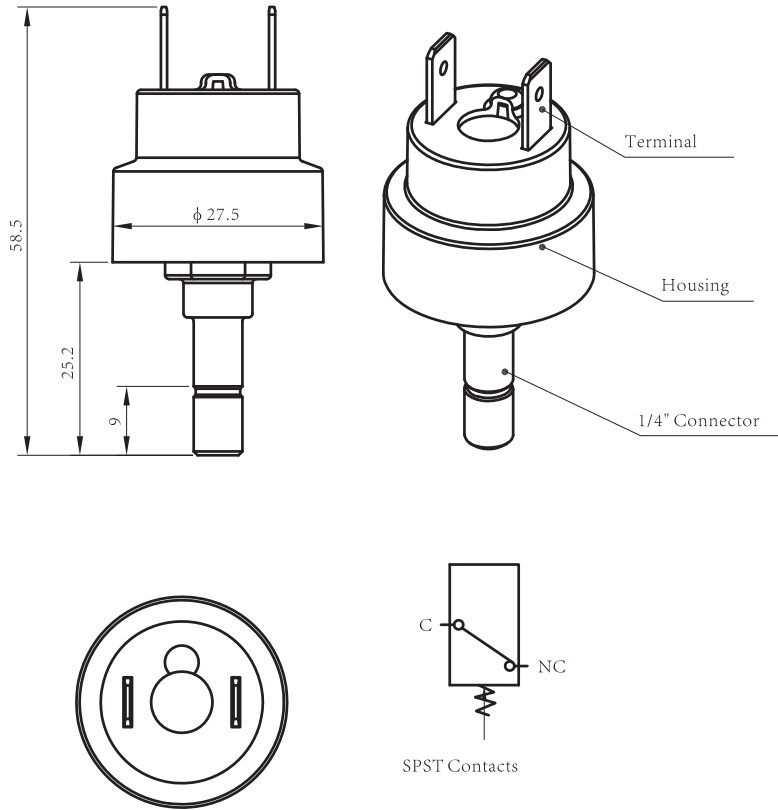

Dimension in: mm

This product is specially designed for water purifier, which can replace traditional high-low pressure switch. It is more sensitive action and used for wider range of applications.

## Specification

Item	LF08E
Pressure range	0.05~0.35MPa
Performance	One pressure setting/ Two pressure setting
Proof pressure	1.2MPa
Burst pressure	3.2MPa
Terminal	6.3mm or 4.8
Temperature range	-20°C~120°C
Circuitry	SPST(NC or NO)
Electric rating	250VAC 3A
Media	Air , Water

# LF08H

Small multi-purpose pressure switch

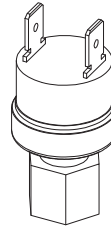
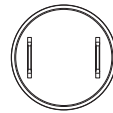
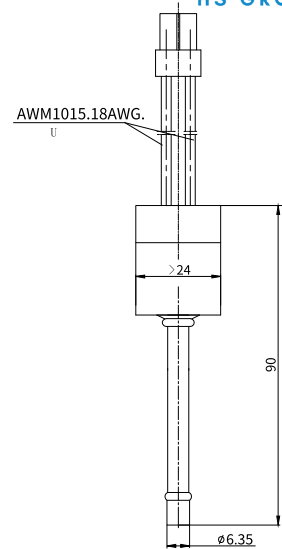
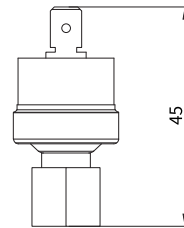
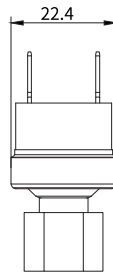

Dimension in:mm

This product is generally used for cooling fans, long life can be applied to the frequent start of fan fans. This product can also meet the demand for pressure control equipment with relatively long service life requirements.

## LF08H Order Ref NO

LF08H - 1111 - 145-175psi

**A B C D** Pressure setting: Reset pressure 145psi  
Action pressure 175psi

Number	Circuitry	Base Material	Connection	Electrical connections
1	<b>A</b> SPST-NC	<b>B</b> brass	<b>C</b> 1/8NPT	<b>D</b> 6.35×0.8
2	SPST-NO	plated steel	1/4NPT	4.8×0.8
3	SPDT	/	R1/8	18AWG Wire leads
4	/	/	R1/4	/
5	/	/	G1/8	/
6	/	/	G1/4	/
7	/	/	1/4 Copper tube	/
8	/	/	7/16UNF Male	/
9	/	/	7/16UNF Female	/
10	/	/	7/16UNF Female with deflector	/

## Specification

Model	LF08H		
Media	Air, Water, motor oils, transmission oils, Hydrocarbon Media, Refrigeration fluid		
Pressure Range/ Tolerance/ Proof Pressure	Pressure Range	Tolerance	Proof Pressure
	0.2~6bar (low pressure)	±0.5bar	15bar
	6~10bar	±0.7bar	35bar
	11~20bar	±1bar	45bar
	21~30bar	±1.5bar	
	31~45bar	±1.5bar	
Burst Pressure	5000psi		
Operating Temperature Range	Environment temperature: low pressure: -30~65 , High pressure: -35~120 ;		
Switch Type	SPST (NC OR NO); SPDT		
Electric Rating	250VAC, 0.02~10A		
Endurance	300000		

Conversion: 1bar=14.5psi 1MPa=10bar

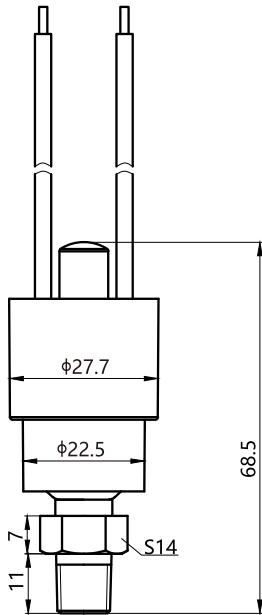

Dimension in:mm

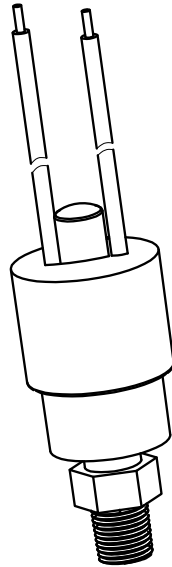

# LF08M

Small multi-purpose pressure switch



LF08M is an overload pressure switch, the maximum pressure set point can reach 750 PSI, the maximum rated current is 25A, and the switch can be normally open or normally closed. It is widely used in refrigeration units, various air conditioners, air compressors, oil pumps and other industrial equipment that need to adjust the pressure of the medium by themselves to protect the pressure system.

LF08M Order Ref NO

LF08M-1 1 1 1 - 145-175psi

**A B C D** Pressure setting: Manual reset pressure 145psi Action pressure 175psi

Number	Circuitry	Base Material	Connection	Electrical connections
1	<b>A</b> SPST-NC	<b>B</b> brass	<b>C</b> 1/8NPT	<b>D</b> 18AWG wire harness
2	SPST-NO	plated steel	1/4NPT	/
3	SPDT	/	R1/8	/
4	/	/	R1/4	/
5	/	/	G1/8	/
6	/	/	G1/4	/
7	/	/	Copper tube	/
8	/	/	7/16UNF Male	/
9	/	/	7/16UNF Female	/
10	/	/	7/16UNF Female with deflector	/

## Specification

Model		LF08M	
Media	Air, Water, motor oils, transmission oils, Hydrocarbon Media, Refrigeration fluid		
Pressure Range/ Tolerance/ Pressure value	Pressure Range	Tolerance	Proof Pressure
	0.2~6bar (low pressure)	±0.5bar	15bar
	6~10bar	±0.7bar	35bar
	11~20bar	±1bar	45bar
	21~30bar	±1.5bar	
	31~45bar	±1.5bar	
Burst Pressure	5000psi		
Operating Temperature Range	Environment temperature: low pressure -30~65°C, High pressure: -35~120°C; Medium temperature: -50~120°C		
Switch Type	SPST(NC OR NO); SPDT		
Electric Rating	120VAC, 6FLA, 34.8LRA; 240VAC, 3FLA, 15LRA	Single point action (pressure difference ≤0.05Mpa): 250VAC/0.5A 36VDC/0.5A	
	120/240VAC, 375VA; 36VDC, 15AMP; 3A		
Endurance	10000		
Connection	Please see the selection table (customizable)		
Electrical connections	Wire connection (can be customized length and electrical plug)		

Conversion: 1bar=14.5psi 1MPa=10bar

# LF08V

Small vacuum Pressure switch

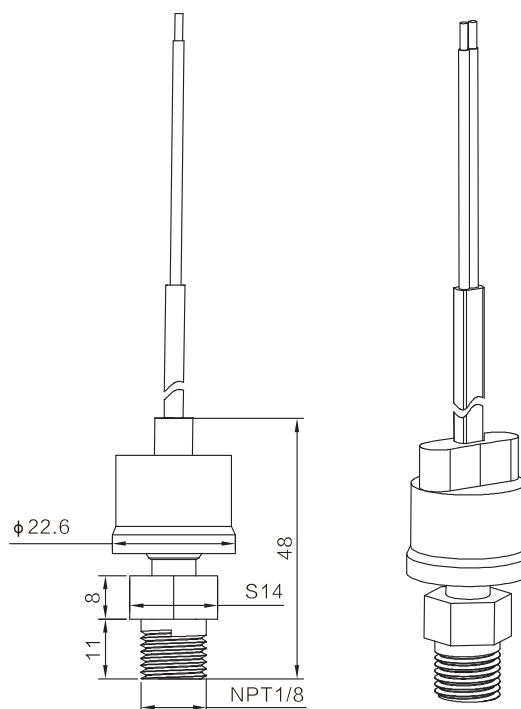

Dimension in : mm

LF08V series pressure switch is designed automatic reset switch, used in vacuum environment, vacuum system applicable to electric car.

## LF08V Order Ref NO

LF08V-1 1 1 1 -0.4-0.75bar

**A B C D** Pressure setting: Reset pressure 0.4bar Action pressure 0.75bar

Number	Circuitry	Base Material	Connection	Electrical connections
1	<b>A</b> SPST-NC	<b>B</b> brass	<b>C</b> 1/8NPT	<b>D</b> 6.35×0.8
2	SPST-NO	plated steel	1/4NPT	18AWG Wire harness
3	/	/	G1/8	Protective sleeve
4	/	/	G1/4	/
5	/	/	custom-made	/

## Specification

MODEL		LF08V		
Media	Air,Water,motor oils,transmission oils,Hydrocarbon Media,Refrigeration fluid			
Pressure Range/ Tolerance	Action pressure	Reset pressure	Tolerance	
	-0.5~-0.8bar	-0.25~-0.6bar	±0.05bar	
	Differential pressure≥0.25 bar			
Burst Pressure	10bar			
Operating Temperature Range	Environment temperature:-20~65°C			
Switch Type	SPST(NC OR NO)			
Electric Rating	120Vac 6FLA,40.2LRA; 240Vac 4FLA,26LRA			
	120/240Vac 375VA;36Vdc 3A			
Endurance	300000			
Connection	Please see the selection table (customizable)			
Electrical connections	6.35*0.8 ; Wire connection (can be customized length and electrical plug)			

Conversion:1bar=14.5psi 1MPa=10bar

# LF10

## Air compressor pressure switch

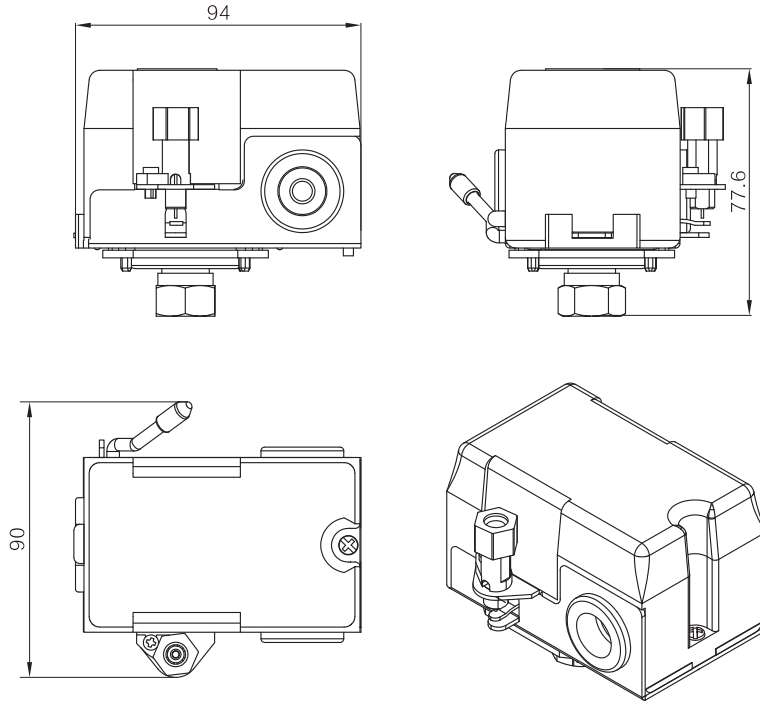

Dimension in:mm

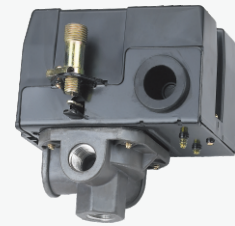

The LF10 pressure switches are used to regulate the tank pressure between two preset values on small (up to 200psi) electrically driven air compressors. They are available with an unloader valve, which prevents compressors from starting under load, and an auto-off disconnect lever for manual cut off the compressor. A four port manifold style is available which provides a means for easy mounting of valves and gauges.

### LF10 Order Ref NO

LF10 (A) -4 H 1 1 1 2 3 -85psi-115psi  
**A B C D E F** Pressure setting:Cut in 85psi Cut off 115psi

Number	Connection Type	Connection Size	Unloader Valve Type	Unloader Valve Connection	Handle Type
0	/	/	Without	Without	Without
1	single port <b>B</b> female	<b>C</b> 1/4NPT	<b>D</b> vertical	Φ6.0mm	long and bend
2	/	male	3/8NPT	horizontal	<b>E</b> Φ6.4mm long and straight
3	/	/	R1/4	/	Φ6.5mm <b>F</b> short and bend
4	<b>A</b> four ports	/	R3/8	/	short and straight
5	/	/	G1/4	/	/
6	/	/	G3/8	/	/

### Specification

Model	Media	Operating Pressure Range	Factory Setting	Differential	Electrical Rating	Contact Arrangement	Connection
LF10	Air	25-100psi	55-80psi	20-35psi	20A/120VAC 12A/240VAC	NC	1/4,3/8Male or Female NPT (1Port) 1/4 Female NPT (4Ports)
	Air	35-150psi	85-115psi	30-40psi			
	Air	50-175psi	110-150psi	35-55psi			
	Air	70-190psi	130-175psi	40-55psi			
LF10A	Air	25-100psi	55-80psi	20-35psi	26A/120VAC 26A/240VAC	NC	1/4,3/8Male or Female NPT (1Port) 1/4 Female NPT (4Ports)
	Air	35-150psi	85-115psi	30-40psi			
	Air	50-175psi	110-150psi	35-55psi			
	Air	70-190psi	130-175psi	40-55psi			

Conversion:1kgf/cm<sup>2</sup>=14.2psi 1bar=14.5psi Other connections are available on request.

# LF10-L

Air compressor  
pressure switch

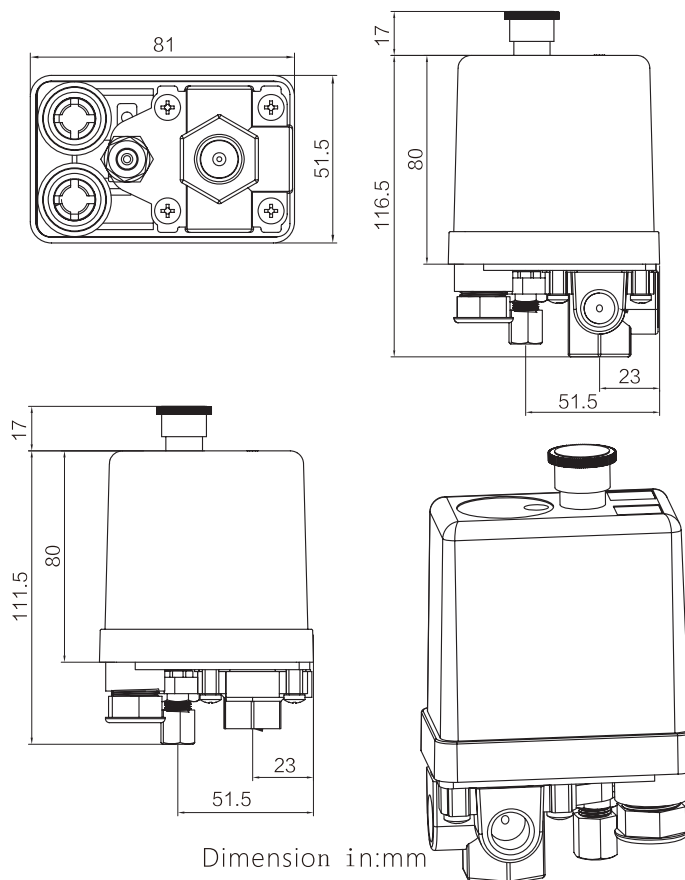

Dimension in:mm

The LF10-L pressure switch is a pressure-operated electric switch for use in regulating the tank pressure between two preset values on electrically driven air compressors. It is available with an unloader valve, which prevents compressors from starting under load, and an On-Off button for manual cut off the compressor. A four port manifold style is available.

## LF10-L Order Ref NO

LF10-L -4 H 1 1 1 2 -85psi-115psi

**A B C D E** Pressure setting:Cut in 85psi Cut off 115psi

Number	Connection Type	Connection Size	Unloader Valve Type	Unloader Valve Connection
0	/	/	/	Without
1	single port	<b>B</b> female	<b>C</b> 1/4NPT	<b>D</b> Copper Φ6.0mm
2	/	/	3/8NPT	Plastic <b>E</b> Φ6.4mm
3	/	/	R1/4	Φ6.5mm
4	<b>A</b> four ports	/	R3/8	/
5	/	/	G1/4	/
6	/	/	G3/8	/

## Specification

Model	Media	Operating Pressure Range	Factory Setting	Differential	Electrical Rating	Contact Arrangement	Connection
LF10-L1H	Air	45-175psi	85-115psi	30-45psi	120VAC, 20A	NC	G1/4,G3/8 or 1/4,3/8NPT Female
LF10-L4H	Air	45-175psi	85-115psi	30-45psi	120VAC, 20A	NC	G1/4,G3/8 or 1/4, 3/8NPTFemale (Four ports)

Other pressure settings and differential are available on request.

Other connections are available on request.

Conversion:1kgf/cm<sup>2</sup>=14.2psi 1bar=14.5psi

# LF10-W

## Pump pressure switch

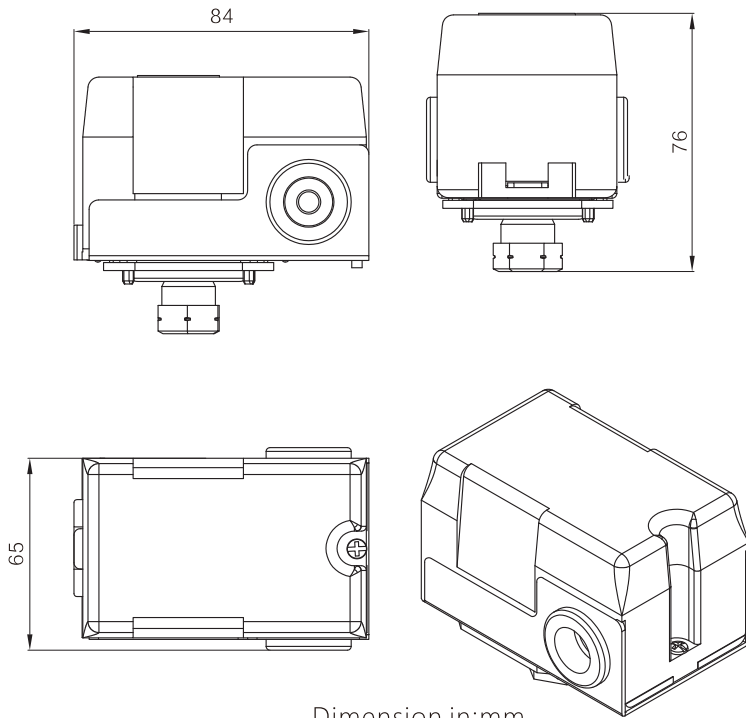

Dimension in:mm



### LF10-WS and LF10-WR Order Ref NO

LF10 (A) -W (S or R) -1 1 1 -30-50psi

Contact Type: **NC** **NO** **A B C** Pressure setting: Cut in 35psi Cut off 50psi

LF10-W series pressure switches provide time tested, reliable control for automatic water systems. The switch is universally acceptable for use as original equipment on water well pumps or pumping systems.

Number	Connection Type		Connection Size
1	<b>A</b> single port	<b>B</b> female	<b>C</b> 1/4NPT
2	/	male	3/8NPT
3	/	/	R1/4
4	/	/	R3/8
5	/	/	G1/4
6	/	/	G3/8
7	/	/	NPT1/4 Long Male
8	/	/	G1/4 Bolt Connectin

### Specification

Model	Media	Operating Pressure Range	Factory Setting	Differential	Electrical Rating	Contact Arrangement	Connection
LF10-WS (LF10A-WS)	Water	15-82psi	20-35psi	15-30psi	120VAC, 20A (120VAC, 26A) 240VAC, 12A (240VAC, 26A)	NC	1/4NPT Male or Female
	Water	30-100psi	30-50psi	20-35psi			
	Water	35-150psi	85-115psi	30-40psi			
LF10-WR (LF10A-WR)	Water	80-15psi	50-30psi	17-30psi	240VAC, 20A (120VAC, 26A) 240VAC, 12A (240VAC, 26A)	NO	1/4NPT Male or Female
	Water	100-30psi	100-75psi	25-30psi			
	Water	150-35psi	125-95psi	30-45psi			

Conversion: 1kgf/cm<sup>2</sup>=14.2psi 1bar=14.5psi Other connections are available on request.

# LF12

## Air Pressure Switches

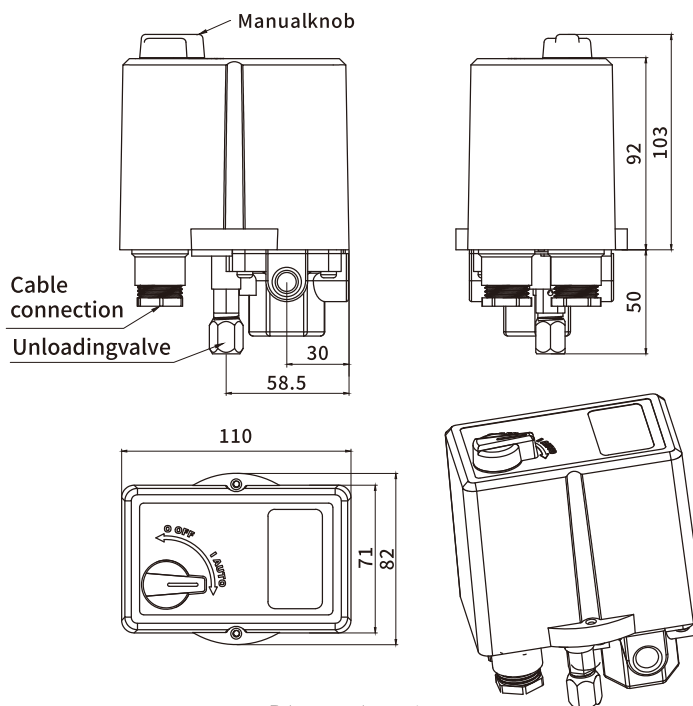

Dimension in:mm

LF 12 is three phase pressure switch ,used for air compressor and water pump to regulate pressure between two preset values. It is available with an unloader valve,which prevents compressor from starting under load and an On-Off knob for manual cut off the compressor or pump. A four port manifold style is available ,which makes easy mounting of other parts for air compressor ,like valve and gauge. LF12 is available with thermal relay for overload protection.The relay will cut off the motor power timely to prevent the motor from burning when motor is overloaded.

### LF12 Pressure Range

Model	Operating Pressure Range	Differential Range	Factory Setting
LF12	1-6bar	0.7-2bar	2/3bar
	3-11bar	1.5-3.5bar	6/8bar
	6-16bar	2-7bar	9/12bar
	5-25bar	3-8bar	16/20bar
	12-35bar	3-8bar	25/30bar

### LF12Order Ref NO

LF12-1-1-1-1-1

NO.	Connection Type	Female Connection Size	Unloader Valve Type	Unloader dimensions	Current ranges
	Single port	G1/4+3*G1/4	No unloader valve	without	2.5-4A
	Four port	R1/4+3*R1/4	Vertical M12 (Brass)	φ6.0-φ6.1	4-6.3A
		1/4NPT+3*1/4NPT	Vertical φ6 tube quick connection (brass)	φ6.4-φ6.5	6.3-10A
		G3/8+3*G1/4	vertical oil resistant M12 (brass)		10-16A
		R3/8+3*R1/4	Vertical Oil Resistant φ6 Tube Quick connection (Brass)		16-20A
		3/8NPT+3*1/4NPT	vertical oil resistant M12 (zinc alloy)		
		G1/2+3*G1/4	Level Oil resistant M12 (zinc alloy)		
		R1/2+3*R1/4			
		1/2NPT+3*1/4NPT			

PS: Contact us if you have special request

### Specification

Medium	water, air	Operating temperature	-40~82°C (fluid)
Contact	Multi-pole single-throw (normally closed)	Protection class	IP54
Electrical rating	Single-phase 120VAC/10A ;	Cable Specifications	10AWG-14AWG
	230VAC/10A	Contact material	Static contact: silver alloy;moving contact: silver alloy
	Three-phase 120VAC/10A ;	Appendix	Chinese/English manual
	230VAC/10A;	air tightness	no leakage when the switch is held at 1.2 times the maximum working pressure for one minute
	400VAC/7.5A; 400VAC/11A;	usage frequency	It takes 30 minutes to cool down for the thermal relay to start
500VAC/6A; 500VAC/9A;		Motor cycle frequency more than 5 minutes	
690VAC/4.5A; 690VAC/6.5A			

# LF15

## Pressure Switch

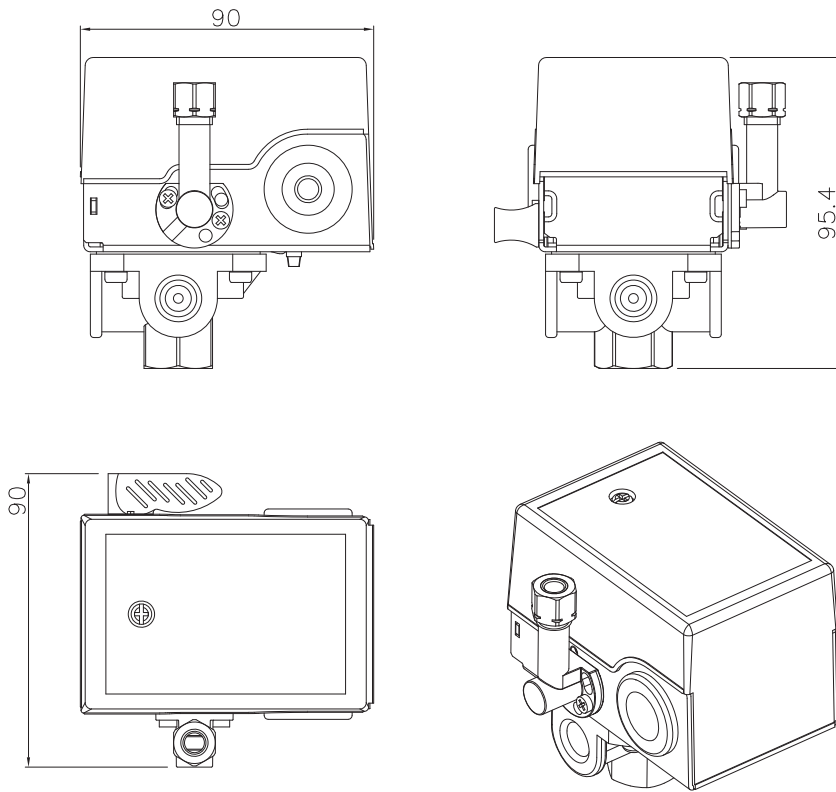

Dimension in: mm

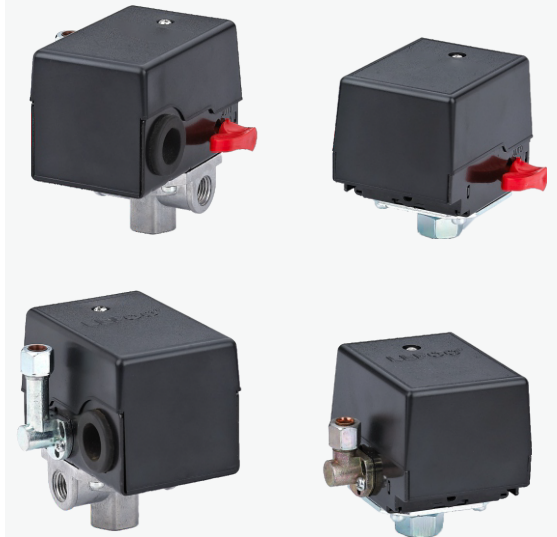

Lf15 series pressure switches, this product is used for adjusting the pressure which in the compressor tank to operate between two preset pressure values. The pressure switch with an unloading valve prevents the air compressor from overloading and the handle is supposed to manually power off the compressor. The four-way base connection makes the installation of additional parts more convenient.

### Specification

Model	LF15
Media	Air, non-flammable or non-hazardous non corrosive gases
Pressure adjusting range	0.3-1.2Mpa
Differential pressure range	0.15-0.45Mpa
Factory settings	according to user's requirements
Pressure setting point tolerance	≤5% (Operating pressure value)
Max. working pressure	1.2Mpa
Rated voltage, current, frequency	120VAC/240VAC,26A/20A,50HZ/60HZ
Contact mode	NC
Connector Type	Female-1-Port, Male-1-Port, F/M-2-Port, Female-4-Port
Interface thread	NPT1/4、R1/4、G1/4 (could be customized)
Unloading valve	Without/with
Direction of unloading valve	As required
Liner diameter of unloading valve	Φ6.0mm、Φ6.4mm、Φ6.5mm(could be customized)
Manual Mode	Without/with
Working Temperature	-20°C~80°C
Voltage resistance	No breakdown in one minute under 2500V
Way to installation	vertically/horizontally
Protection grade	Ip20

# LF16

Pump pressure switch

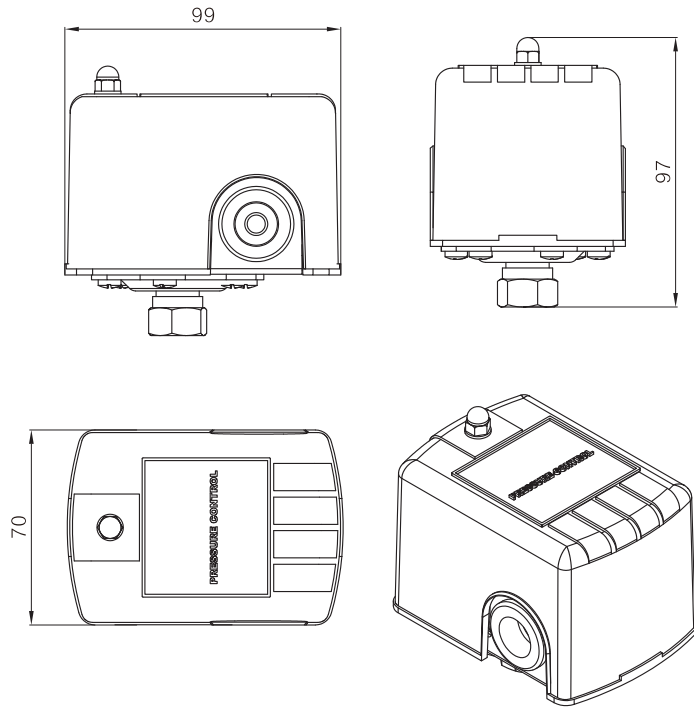

Dimension in:mm

LF16 pressure switches provide time tested, reliable control for automatic water systems. The switch is universally acceptable for use as original equipment on water well pumps or pumping systems.

## LF16 Order Ref NO

LF16(-1) -1 1 1 -30-50psi

A B C Pressure setting:Cut in 30psi Cut off 50psi

Number	Connection Type		Connection Size
1	A single port	B female	C 1/4NPT
2	/	male	3/8NPT
3	/	/	R1/4
4	/	/	R3/8
5	/	/	G1/4
6	/	/	G3/8

## Specification

Model	Min On (Cut-In) psi	Min Off (Cut-Out) psi	Differential psi	Factory Setting psi	Electrical Rating			Contact Arrange- ment	Connection
					1Phase 120VAC	3Phase 240VAC	240VAC		
LF16	20	80	15-30	20-40	2HP	3HP	5HP	NC	1/4 Male or Female NPT
			15-30	30-50					
			15-35	40-60					
LF16-1	20	80	20-35	70-100	1.5HP	2HP	3HP		
			15-30	20-40					
			15-30	30-50					
LF16-1	40	100	15-35	40-60	2HP	3HP	5HP		
			20-35	70-100					

Conversion:1kgf/cm<sup>2</sup>=14.2psi 1bar=14.5psi Other connections are available on request.

# LF17

## Air compressor pressure switch

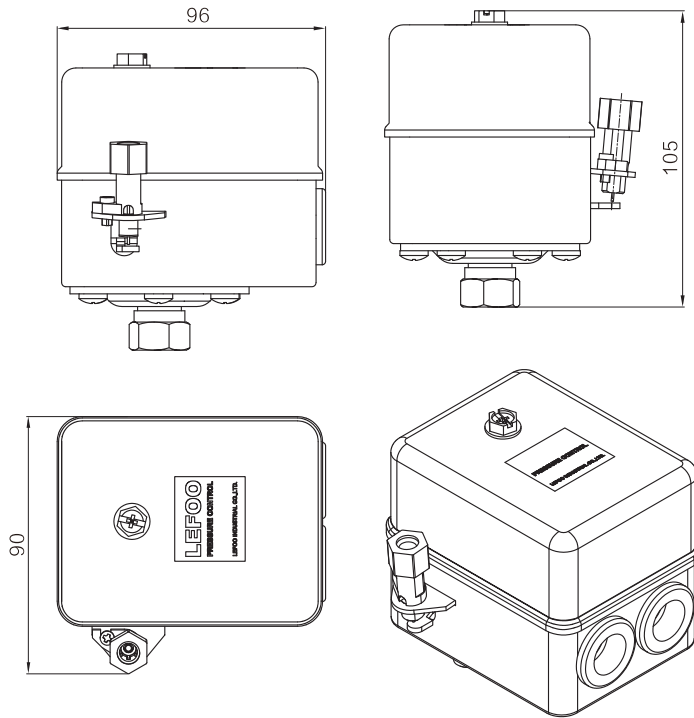

Dimension in:mm



### LF17 Order Ref NO

LF17(A) -1 H 1 1 1 2 -145-175psi  
**A B C D E** Pressure setting:Cut in 145psi Cut off 175psi

The rugged LF17 pressure switch is designed for the demanding requirements of larger, heavy duty commercial air compressors (up to 250 psi). The sturdy painted steel case and cover resists the harsh conditions encountered in industrial applications. This style is also available with an unloader valve to prevent the compressor from starting under load .

Number	Connection Type		Connection Size	Unloader Valve Type	Unloader Valve Connection
1	<b>A</b> single port	<b>B</b> female	<b>C</b> 1/4NPT	<b>D</b> vertical	Φ6.0mm
2	/	male	3/8NPT	horizontal	<b>E</b> Φ6.4mm
3	/	/	R1/4	/	Φ6.5mm
4	/	/	R3/8	/	/
5	/	/	G1/4	/	/
6	/	/	G3/8	/	/

### Specification

Model	Media	Operating Pressure Range	Factory Setting	Differential	Electrical Rating	Contact Arrangement	Connection
LF17	Air	40-250psi	140-175psi	35-60psi	120VAC, 24A 240VAC, 20A	NC	1/4,3/8NPT Male or Female
	Air	15-60psi	30-45psi	15-20psi			
LF17A	Air	240-500psi	325-400psi	55-70psi	120VAC, 30A 240VAC, 25A		

Conversion:1kgf/cm<sup>2</sup>=14.2psi 1bar=14.5psi

# LF17-W

Pump pressure switch

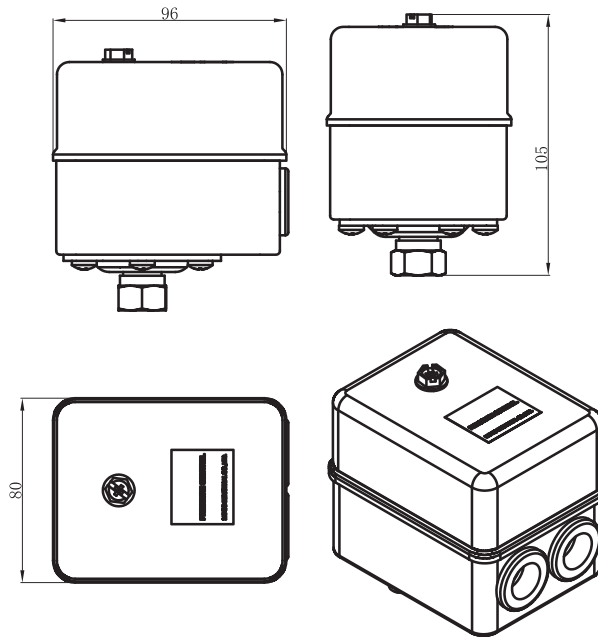

Dimension in:mm

The rugged LF17 pressure switch is designed for the demanding requirements of larger, heavy duty commercial water pump system.

## LF17-W Order Ref NO

LF17-W -1 1 1 -80-100psi

A B C Pressure setting:Cut in 80psi

Cut off 100psi

Number	Connection Type		Connection Size
1	A single port	B female	C 1/4NPT
2	/	male	3/8NPT
3	/	/	R1/4
4	/	/	R3/8
5	/	/	G1/4
6	/	/	G3/8

## Specification

Model	Media	Operating Pressure Range	Factory Setting	Differential	Electrical Rating	Contact Arrangement	Connection
LF17-W	Water	40-250psi	80-100psi	20-60psi	120VAC, 24A 240VAC, 20A	NC	G,NPT1/4, 3/8 Male or Female
	Water	14-100psi	40-70psi	14-50psi			
LF17-W5	Water	15-60psi	30-45psi	7-20psi			

Conversion:1kgf/cm<sup>2</sup>=14.2psi 1bar=14.5psi

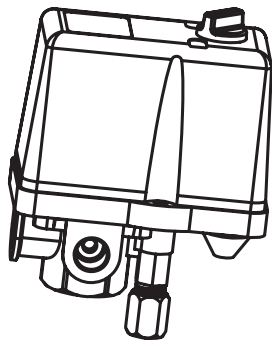
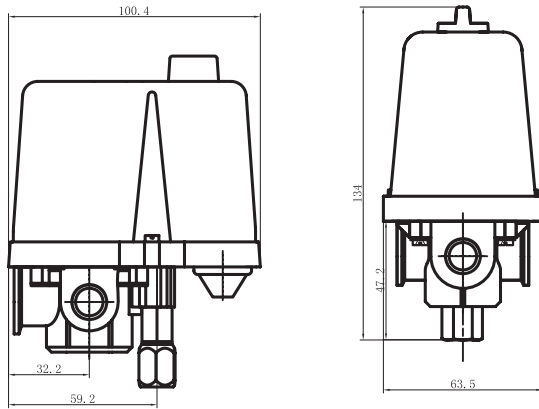

Dimension in:mm

# LF18

Air compressor and pump pressure switch



The LF18 pressure switch is used to regulate the tank pressure between two preset values on 3 phase electrically driven air compressors. It is available with an unloader valve, which prevents compressors from starting under load, and it is available with an On-Off knob for manual cut off the compressor.

## LF18 Order Ref NO

LF18 -4 H 1 1 1 1 2 -85psi-115psi

**A B C D E F** Pressure setting:Cut in 8bar Cut off 115psi

Number	Connection Type	Connection Size	Unloader Valve Type	Unloader Valve Connection	Handle Type
0	/	/	without	without	without
1	single port <b>B</b> female	<b>C</b> G1/4	<b>D</b> vertical(brass)	Φ6.0mm	<b>F</b> ON/OFF Knob
2	/	G1/2	vertical(zinc alloy)	<b>E</b> Φ6.4mm	/
3	two ports	1/4NPT	horizontal(zinc alloy)	Φ6.5mm	/
4	<b>A</b> four ports	1/2NPT	horizontal(plastic)	/	/
5	/	R1/4	/	/	/
6	/	R1/2	/	/	/

## Specification

Model	Media	Operating Pressure Range	Factory Setting	Differential	Electrical Rating	Contact Arrangement	Connection
LF18	Air	1.0-5.0bar	2.0-4.0bar	1.0-3.0bar	400VAC-3 16A/25A	NC	1/4 or 1/2NPT, G1/4 or 1/2 Female
		2.0-8.0bar	3.8-5.0bar	1.0-3.0bar			
		3.0-11.0bar	5.6-7.0bar	1.4-4.0bar			
		4.0-16.0bar	8.0-10.0bar	1.8-4.5bar			

Conversion:1kgf/cm<sup>2</sup>=14.2psi 1bar=14.5psi Other connections are available on request.

# LF19

Air compressor and pump pressure switch

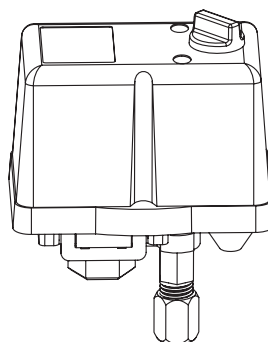
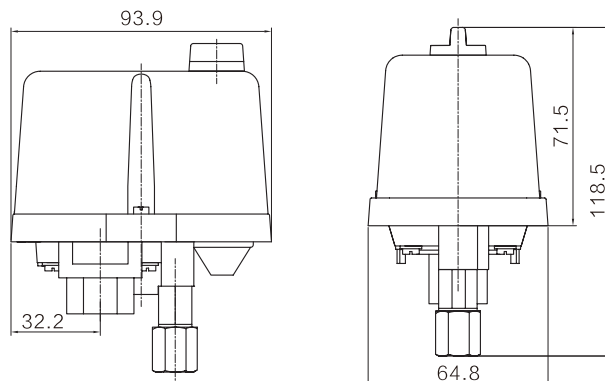

Dimension in:mm

LF19 pressure switches provide time tested, reliable control for automatic water systems. The switch is universally acceptable for use as original equipment on water well pumps or pumping systems. It is available with an On-Off knob for manual cut off of the pump.

## LF19 Order Ref NO

LF19 -4 1 1 1 2 1 -7.5-10.5bar

**A B C D E F**

Pressure setting:Cut in 7.5bar

Cut off 10.5bar

Number	Connection Type	Connection Size	Unloader Valve Type	Unloader Valve Connection	Handle Type
0	/ /	/	without	without	without
1	single port <b>B</b> female	<b>C</b> G1/4	<b>D</b> vertical(brass)	Φ6.0mm	<b>F</b> ON/OFF Knob
2	/ /	G1/2	vertical(zinc alloy)	<b>E</b> Φ6.4mm	/
3	three ports /	1/4NPT	horizontal(zinc alloy)	Φ6.5mm	/
4	<b>A</b> four ports /	1/2NPT	horizontal(plastic)	/	/
5	/ /	R1/4	/	/	/
6	/ /	R1/2	/	/	/

## Specification

Model	Media	Unloader Valve	Operating Pressure Range	Factory Setting	Differential	Electrical Rating	Contact Arrangement
LF19	Air	With	1-6bar	2-4bar	1-3bar	250VAC 16A/25A	NC
			2-11bar	6-8bar	1.4-3.5bar		
			5-14bar	8-10bar	1.8-4.0bar		

Conversion:1kgf/cm<sup>2</sup>=14.2psi 1bar=14.5psi

# LFPC-1

Automatic water pump controller

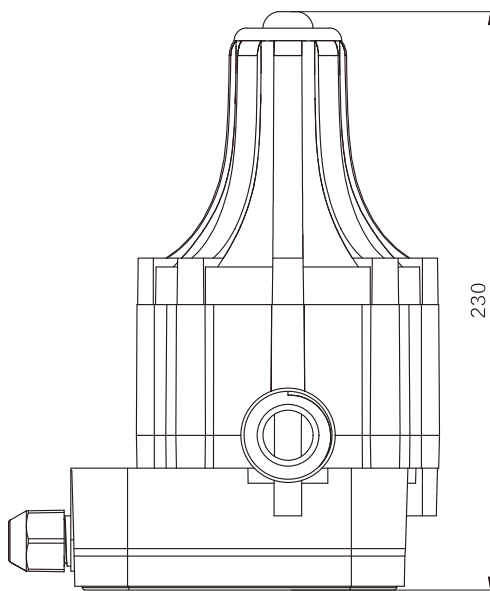
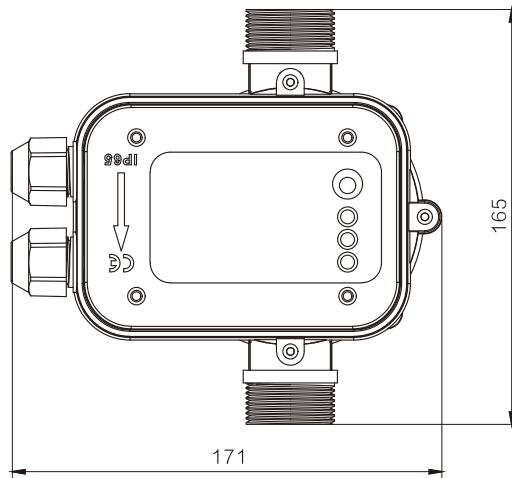

Dimension in: mm



Automatic water pump controller is the electronic intelligent water pump control equipment, which can completely replace traditional strong power control system composed of pressure tank, pressure switch, water shortage protection device, check valve and four ports, also saving time and material when installation. Control cabinet with complete isolation of electric part and pipe and high sealing make controller own characteristics of safety, environmental protection, long life, stable performance, less maintenance and no noise, which is better than traditional pressure and preferred by family.

### Matters need attention:

1. Setting pressure is not adjustable.
2. Need to install on water pump with power greater than 200W.
3. Don't install any faucet between controller and pumps.
4. The distance between controller and the highest faucet shouldn't exceed 15M.

### Specification

Model	LFPC-1
Rated voltage	220-240VAC
Maximum working pressure	10bar
Frequency	50-60Hz
Connection	R1"
Maximum current	8A
Protection level	IP65
Maximum power	1.5kW(2HP)
Maximum operating temperature	65°C
Factory setting	1.5bar, stop when water pressure reach 3.5bar

# LF20

Extended duty  
Pressure switch

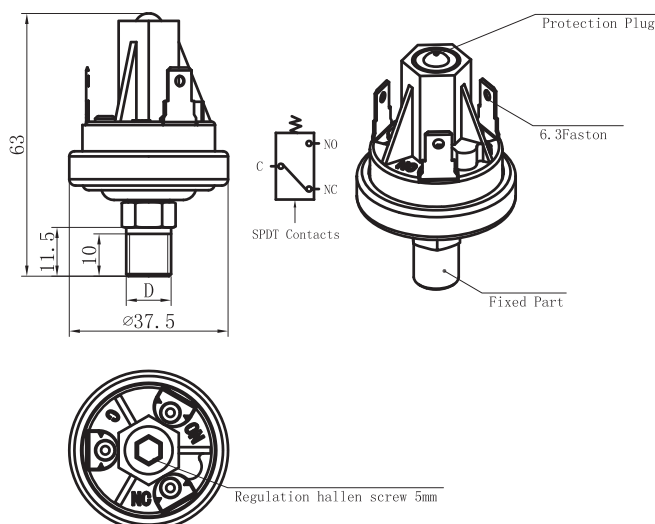

The LF20 pressure switch is specifically designed to stand up to extended duty applications. This switch is factory set but capable of field adjustment. It features different diaphragms for compatibility with a wide variety of fluids, and various terminations including a Metri-Pack connector that forms a tight seal when connected. It can be widely used for pool and spa, anti-skid braking systems, water pump systems, and dental air compressors, heavy construction, off road equipments and other pressure control systems.

## LF20 Order Ref NO

LF20-4 11111 -10Psi

**A B C D E F** Pressure setting: 10psi

Number	Pressure Set Point Range	Circuitry	Base Material	Connection	Terminals	Cover
0	/	/	/	/	/	none
1	0.5-1psi±0.3psi	<b>B</b> SPST-NC	<b>C</b> brass	<b>D</b> 1/8NPT	<b>E</b> 1/4 blade	<b>F</b> cover A
2	1.1-3psi±0.5psi	SPST-NO	plated steel	1/4NPT	#8-32 screws	cover B
3	3.1-7psi±1psi	SPDT-NO-C-NC	stainless steel	R1/8	wire leads	/
4	<b>A</b> 8-13psi±2psi	SPST-NO(adjustable)	/	R1/4	/	/
5	14-24psi±3psi	SPDT-NO-C-NC(adjustable)	/	G1/8	/	/
6	25-50psi±5psi	/	/	G1/4	/	/
7	51-90psi±7psi	/	/	/	/	/
8	91-150psi±10psi	/	/	/	/	/

## Specification

MODEL	LF20
Media	Air,water,motor oils,transmission oils,jet fuels and other similar Hydrocarbon Media
Pressure Set Point	Factory set from 0.5 to 150psi
Max Operating Pressure	150psi for 0.5 - 24psi-set point range , 250psi for 25-150psi set point range
Proof Pressure	500psi
Burst Pressure	750psi for 0.5-24psi set point range, 1250psi for 25-150psi set point range
Operating Temperature Range	-40°C to +120°C
Switch Type	Direct action,blade contact
Electric Rating	Resistive : 15AMP-6VDC, 8AMP-12VDC, 4AMP-24VDC Inductive : 1AMP-120VAC, 0.5AMP-240VAC
Contact Arrangement	SPST-N.O,N.C 1circuit adjustable dual circuit,or 2circuits adjustable dual circuit.Also available are N.O/N.O.dual circuit and N.C/N.C.dual circuit
Terminal	#8-32 screws,1/4" blade
Connection	1/8-27NPT Male
Material	Contact:silver alloy,gold plated;Base:brass;Cover:glass reinforced polyester;Diaphragm:polyimide film
Options	Plated Steel,plastic or stainless steel base;various base connector threadsize; wire leads(potted & sealed);Teflon or EPDM diaphragm

Conversion:1kgf/cm<sup>2</sup>=14.2psi 1bar=14.5psi

# LF20-H

## Ultra duty Pressure switch

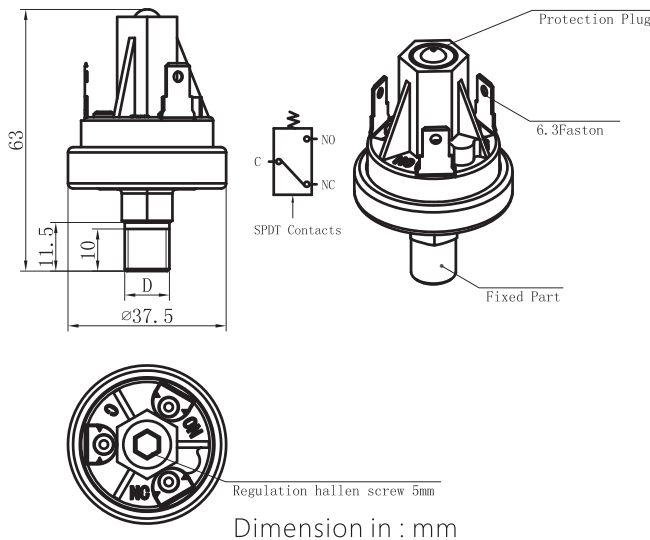

The LF20-H pressure switches are robust, compact and designed to operate in harsh environments at various pressures. The switch is factory calibrated but in the case that adjustment is needed in the field the switch offers an adjustment screw to facilitate any fine tuning required. The standard diaphragm employed is polyimide making it compatible with many gases and liquids. Several other diaphragm materials are available that make the switch compatible with many mediums. Various electrical terminations are available including tabs and a metric-pack connector that forms a tight seal when connected.

### LF20-H Order Ref NO

LF20-H -4 1 2 1 1 1 -175psi

**A B C D E F** Pressure setting: 175psi

Number	Pressure Set Point Range	Circuitry	Base Material	Connection	Terminals	Cover
0	/	/	/	/	/	none
1	10-35psi±3psi	<b>B</b> SPST-NC	/	<b>D</b> 1/8NPT	<b>E</b> 1/4 blade	<b>F</b> cover A
2	35-75psi±7psi	SPST-NO	<b>C</b> plated steel	1/4NPT	#8-32 screws	cover B
3	75-150psi±10psi	SPDT-NO-C-NC	stainless steel	R1/8	wire leads	/
4	<b>A</b> 150-250psi±20psi	SPST-NO(adjustable)	/	R1/4	/	/
5	250-400psi±50psi	SPDT-NO-C-NC(NO.adjustable)	/	G1/8	/	/
6	/	/	/	G1/4	/	/

The polyimide diaphragm is not suit for water, if customer is to use the pressure switch in water, please contact the factory.

### Specification

MODEL	LF20H
Media	Air,water,motor oils,transmission oils,jet fuels and other similar Hydrocarbon Media
Pressure Set Point	Factory set from 10 to 400psi
Max Operating Pressure	500 psi
Proof Pressure	2000 psi
Burst Pressure	4000 psi
Operating Temperature Range	-40°C to +120°C
Switch Type	Direct action,blade contact
Electric Rating	Resistive: 15AMP-6VDC, 8AMP-12VDC, 4AMP-24VDC Inductive: 1AMP-120VAC, 0.5AMP-240VAC
Contact Arrangement	SPST-NO,NC,SPDT
Terminal	#8-32 screws,1/4" blade,Metri-Pack
Connection	1/8"NPT Male,1/4"NPT Male,G1/8"Male,G1/4"Male
Material	Contact:Silver alloy,gold plated ;Base:Plated Steel ;Cover:Glaee reinforced polyester Diaphragm:Polyimide film(other materials is optional according to media)
Options	Base connector sizes,wire leads,NO/NO.dual circuit and NC/NC.dual circuit

Conversion:1kgf/cm<sup>2</sup>=14.2psi 1bar=14.5psi

# LF20-V

Vacuum Pressure switch

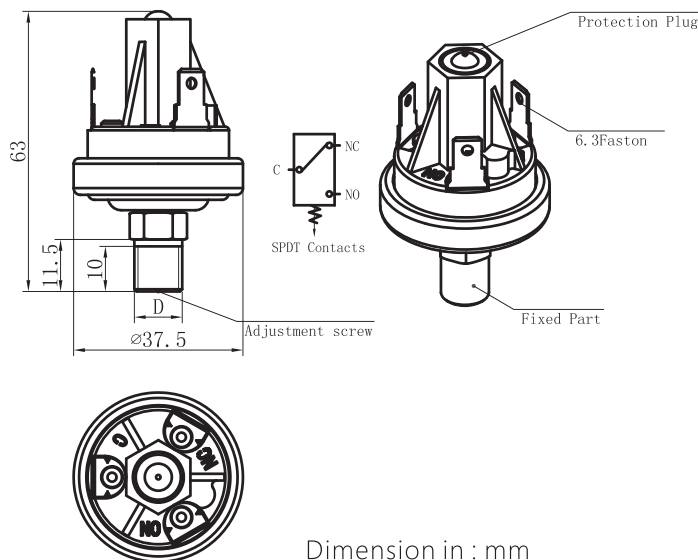

Dimension in : mm

LF20-V vacuum switch is specifically designed to stand up to extended duty applications. This switch is factory set. It features a fluorosilicone rubber diaphragm for compatibility with a wide variety of fluids, and various terminations including a Metri-Pack connector that forms a tight seal when connected. Among the outstanding design benefits are its durable construction, compact size, and enhanced set point integrity.

## LF20-V Order Ref NO

LF20-V -4 1 1 1 1 1 -20"Hg

**A B C D E F** Pressure setting: 20"Hg

Number	Pressure Set Point Range	Circuitry	Base Material	Connection	Terminals	Cover
0	/	/	/	/	/	none
1	1.1-3"Hg(15-41"H2O)±0.5"Hg	<b>B</b> SPST-NC	<b>C</b> barss	<b>D</b> 1/8NPT	<b>E</b> 1/4 blade	<b>F</b> cover A
2	4-8"Hg±1"Hg	SPST-NO	plated steel	1/4NPT	#8-32screws	cover B
3	9-17"Hg±2"Hg	SPDT-NO-C-NC	stainless steel	R1/8	wire leads	/
4	<b>A</b> 18-22"Hg±3"Hg	SPST-NO(adjustable)	/	R1/4	/	/
5	/	SPDT-NO-C-NC(adjustable)	/	G1/8	/	/
6	/	/	/	G1/4	/	/

## Specification

MODEL	LF20-V
Media	Air
Pressure Set Point	Factory set from 1.1 to 22 in/Hg vacuum
Max Operating Pressure	30 in/Hg vacuum
Burst Pressure	150 psi
Operating Temperature Range	-40°C to +120°C
Switch Type	Direct action, blade contact
Electric Rating	Resistive : 15AMP-6VDC, 8AMP-12VDC, 4AMP-24VDC
	Inductive : 1AMP-120VAC, 0.5AMP-240VAC
Contact Arrangement	SPST-NO,NC
Terminal	#8-32 screws,1/4" blade, Metri-Pack
Connection	1/8"NPT Male,1/4"NPT Male,G1/8"Male,G1/4"Male
Material	Contact:Silver alloy,gold plated ; Base:Plated Steel ; Cover:Glaee reinforced polyester ;Diaphragm:Fluorosilicone elastomer
Options	Various base connector sizes,wire leads(potted & sealed)

Conversion:1kgf/cm<sup>2</sup>=14.2psi 1bar=14.5psi 1 in/Hg=0.49psi

# LF25

## Steam pressure switch

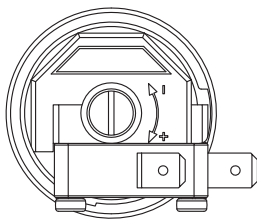
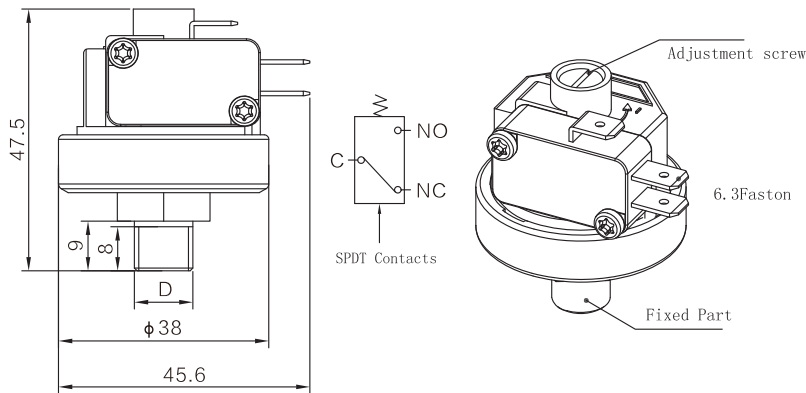

Dimension in:mm

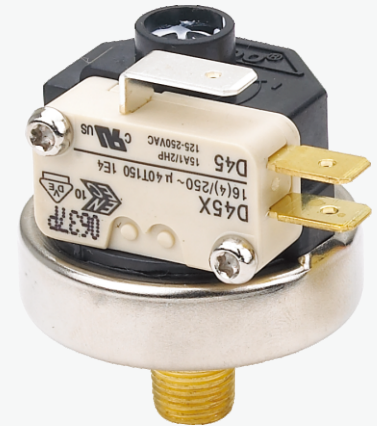

LF25 pressure switch is designed for control pressure with higher current capacity. It is widely used in steam cleaner, steam sadoron and other pressure control system. It provides SPST or SPDT contact form and switch deadband (also referred to as mechanical differential or hysteresis). LF25 switch utilize high-quality miniature snap-action switches. The switch is diaphragm operated. During the development of a specification, actuation point can be adjusted by the designer. In production, factory setting is required.

### LF25 Order Ref NO

LF25 -4 1 1 1 -3.5bar

**A B C D** Pressure setting: Factory set at 3.5bar

Number	Pressure Range	Connection Type (Male)	Electrical Rating	Max operating temperature
1	0.2-0.6bar	<b>B</b> 1/8NPT	<b>C</b> 16A,125-250VAC	<b>D</b> 85℃
2	0.5-1.0bar	G1/8	22A,125-250VAC	125℃
3	1.0-2.5bar	R1/8	/	/
4	<b>A</b> 2.0-4.0bar	1/4NPT	/	/
5	3.0-7.0bar	G1/4	/	/
6	5.0-9.0bar	R1/4	/	/

### Specification

Model	LF25					
Media	Non hazardous gas, liquid or steam					
Operating Pressure	0.2-0.6bar	0.5-1.0bar	1.0-2.5bar	2.0-4.0bar	3.0-7.0bar	5.0-9.0bar
Proof Pressure	3bar	3bar	10bar	10bar	10bar	10bar
Operating Temperature Range	+125℃ Max imum					
Contact Arrangement	SPST or SPDT					
Electric Rating	SPST or SPDT /Normal Close:16(4)-250VAC (other ratings are available if necessary)					
Terminal	6.3 or 4.8mm male Q.C. Insulation cover is available if necessary					
Connection	1/8NPT-27 or 1/4NPT-18 Male (other connection is optional)					

Conversion:1kgf/cm<sup>2</sup>=14.2psi 1bar=14.5psi

# LF30

Air differential pressure switch

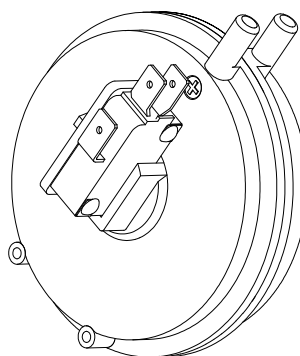
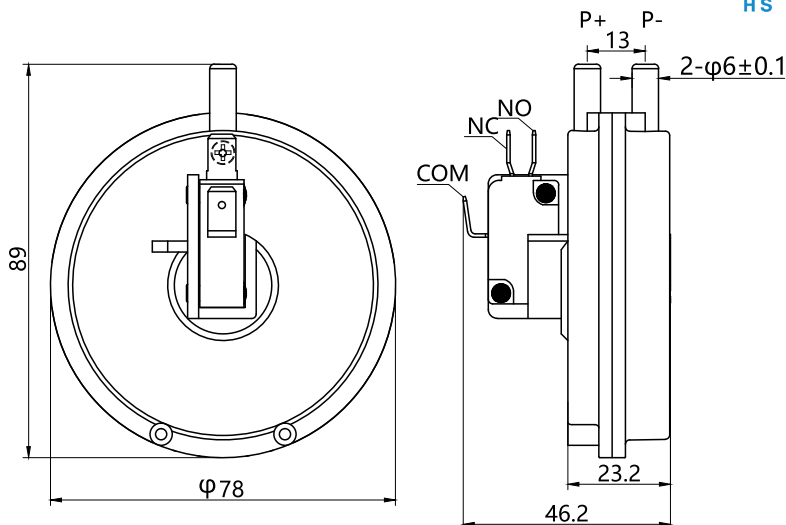

Dimension in:mm

The LF30 employs a differential pressure to actuate a precision snap switch at chosen pressure setting. This may be the difference between atmospheric and a negative or positive pressure or between any two given pressures. When a change of pressure occurs between the negative pressure chamber and the positive pressure chamber the main diaphragm activates the snap switch at a pre-determined value.

## LF30 Order Ref NO

LF30 -4 1 1 1 -P70Pa-100Pa

**A B C D** Pressure setting in pa:P=Positive V=Vacuum  
ON:100Pa OFF:70Pa

Number	Electrical Rating	Terminals	Mounting/Fixing	Orifice
0	/	/	none	none
1	0.1A,125/250VAC	<b>B</b> 6.3×0.8mm	<b>C</b> with bracket	<b>D</b> with orifice
2	3A,125/250VAC	4.8×0.5mm	/	/
3	5A,125/250VAC	/	/	/
4	<b>A</b> 15A,125/250VAC	/	/	/

## Specification

Model	LF30
Medium	Air, smoke (smoke after combustion of gas), non-corrosive gas
Fixing method	L-shaped bracket
Installation	LF 30 should be installed with diaphragm in vertical place, Please contact us before you install it horizontally.
Pressure range	35~1000Pa positive and negative pressure range, the min upper limit pressure is 35Pa, the min lower limit pressure is 6Pa, and pressure difference is not adjustable
Pressure resistance	5000Pa
Operating temperature	≤105°C
Rated voltage, current	0.1A,5A,16A,125/250VAC
Contact method	SPDT or SPST
Terminal	6.35×0.8 or 4.8×0.5 standard flat blade
Tolerance	At room temperature, the tolerance is ±10Pa or ±10%Pa, whichever is greater

Conversion:1mbar=100Pa 1"W.C=249Pa

# LF31

Air differential Pressure switch

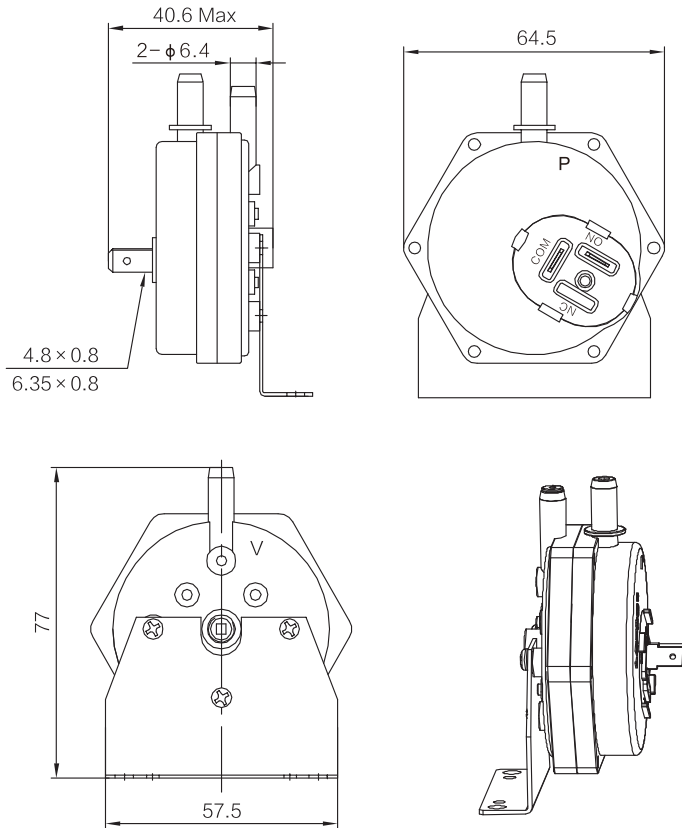

Dimension in : mm



LF31 switches offer pressure, vacuum and differential models capable of sensing very low setpoints, and switching current up to 5A resistive, 2.5A inductive. Designed for use in the HVAC industry, where reliable air proving is critical to both performance and customer safety. The LF31 is a favorite with leading manufacturers of gas-fired warm air furnaces and water heaters.

## LF31 Order Ref NO

LF31 -S P D 0.05 L/ 125 Pa

A B C D E F G

- A Contact Material:**S=Silver,G=GOLD
- B Actuation Mean:**V=Vacuum,P=Positive pressure
- C Contact Arrangement:**S=SPST,D=SPDT
- D Orifice diameter in thing of an inch**
- E Direction of actuation pressure:**L=Increasing,D=Decreasing
- F Set point:**125,norminal set from 0-3000Pa
- G Unit actuation pressure abbreviated:**in W.C.,psi,Pa,mbar,etc

## Specification

MODEL	LF31
Media	Air,products of combustion or natural gas
Operating Pressure Range	0.15in W.C. to 34in W.C.
Mounting Position	Diaphragm in any vertical Plane
Proof Pressure	100in W.C.(3.6psi)
Burst Pressure	5psi Minimum
Operating Temperature	-40°C to +85 °C
Contact Arrangement	SPSP or SPDT
Electrical Rating	Resistance:initial < 50 milliohms Current:100mA minimum,5A(resistive)maximum(fine silver alloy contacts) 15mA minimum,0.5A maximum(gold-platinum-silver alloy contacts)
Termimnal	6.3mm or 4.8mm copper alloy
Connection	Φ6.4mm for tube connection

Conversion:1in W.C.=249Pa 1mbar=100Pa

# LF32

## Air differential Pressure switch

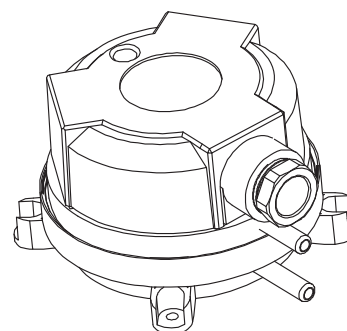
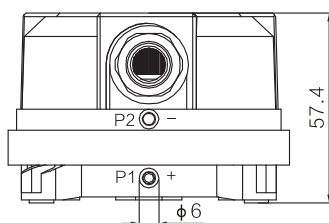
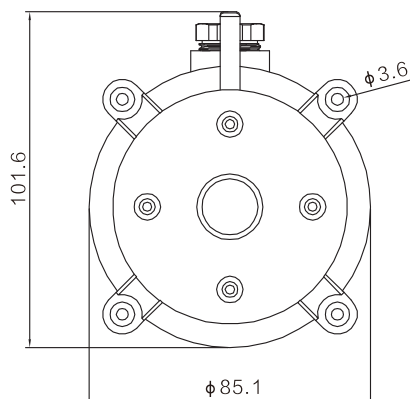
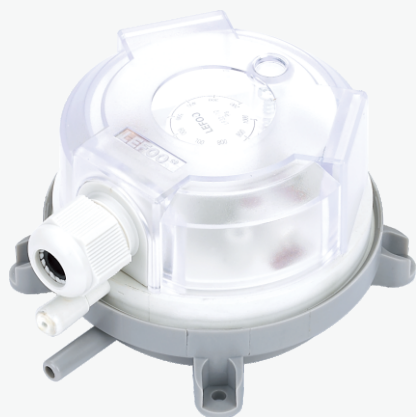

The LF32 is an adjustable differential pressure switch capable of detecting miniscule changes in pressure due to the size and proven design. The switch set point or switching point can be field adjustable without the need of a manometer by simply using the adjustment knob and the built in calibrated visual scale. This switch is equipped a clear cover that not only protects the adjustment knob to be move involuntary but also provides class IP54 protection

Dimension in : mm

### LF32 Pressure Range

Model	Pressure Range	Differential	Tolerances
LF32-02	20-200(Pa)	10(Pa)	≤±15%
LF32-03	30-300(Pa)	10(Pa)	≤±15%
LF32-04	40-400(Pa)	20(Pa)	≤±15%
LF32-05	50-500(Pa)	20(Pa)	≤±15%
LF32-10	200-1000(Pa)	100(Pa)	≤±15%
LF32-25	500-2500(Pa)	150(Pa)	≤±15%
LF32-11	100-1000(Pa)	50(Pa)	≤±15%
LF32-50	1000-5000(Pa)	250(Pa)	≤±15%

### Specification

MODEL	LF32
Media	Air, non-combustible and ono-aggressive gass
Max Operating Pressure	10kPa
Mounting Position	Diaphragm in any vertical Plane
Degree of protection	IP54(with cover),IP00(without cover)
Operating Temperature	-40°C to +85°C
Contact Arrangement	SPDT
Electrical Rating	Resistance:initial < 100 milliohms Current:1.5A(0.4A)/250V
Termimnal	6.3mm ×0.8 blade or screw terminal
Connection	Φ6.4mm for tube connection

Conversion: 1in W.C.=249Pa 1mbar=100Pa

# LF35

Air differential Pressure switch

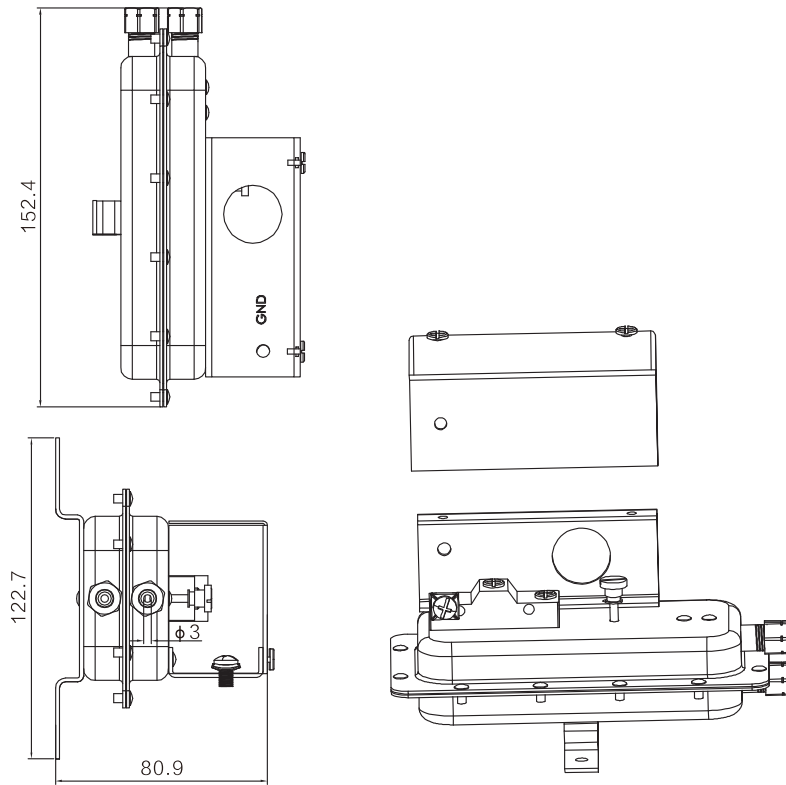

Dimension in : mm

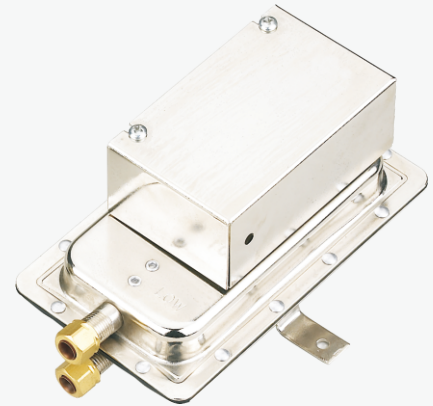

## LF35 Order Ref NO

LF35 - 1 1 A 1 - P0.5mbar

**A B C D** Pressure setting:P0.5mbar P=Positive;V=Vacuum

The LF35 are general purpose airflow proving switches designed for HVAC, detection of blocked filters and fan suction, air flow monitoring in ducts, pipes, tunnels, and other energy management applications. It may be used to sense positive, negative or differential air pressure.

**A Operating Pressure:**1=0.5mbar-30mbar;2=0.2mbar-5.0mbar

**B Connection:**1=accept 0.25"OD rigid or semi-rigid tubing;2=Male 0.25"slip-on connectors,suitable for flexible tubing

**C Mounting/Fixing:**A=Bracket A;B=Bracket B

**D Wire Protecting:**0=None;1=with protecting on closure

## Specification

MODEL	LF35-1	LF35-2
Media	Air	
Mounting Position	Diaphragm in any vertical Plane	
Field Adjustable Range	0.5±0.05mbar to 30.0mbar	0.2±0.05mbar to 5.0mbar
Switch Differential	Progressive,increasing from approximately 0.05mabr at minimum set point,to approximately 2.0mbar at maximum set point	Progressive,increasing from approximately 0.05mabr at minimum set point,to approximately 0.25mbar at maximum set point
Maximum Pressure	30mbar	
Operating Temperature	-40°C~+82°C	
Electrical Rating	300VA pilot duty at 115-277VAC,10A,non-inductive,277AVC	
Connection	Ferrule and nut compression type connectors that accept 0.25"OD rigid or semi-rigid tubing;male 0.25"slip-on connector	
Contact Arrangement	SPDT	

# LF37

Liquid level pressure switch

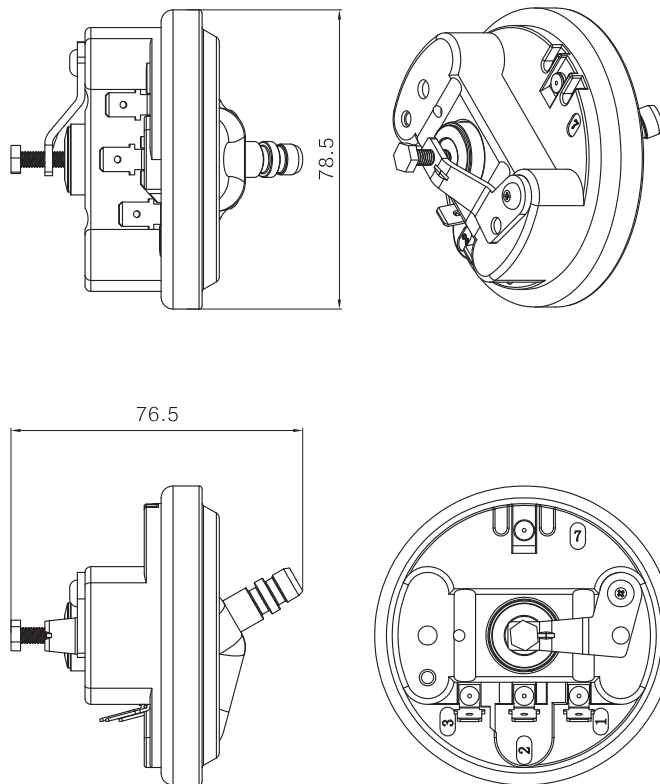
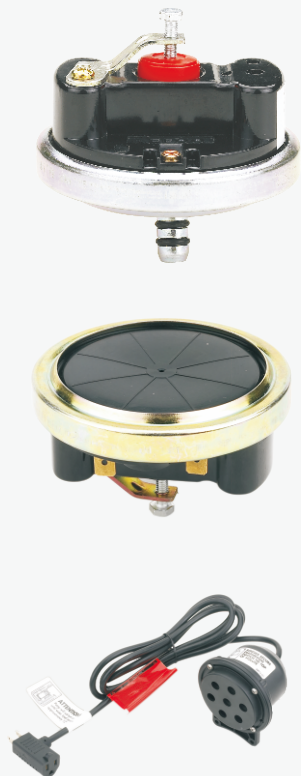

Dimension in:mm

LF37 diaphragm pressure switch is available for various sumps, effluent, and sewage application to control the liquid level. Various switch settings are available for to turn-on or turn-off the pump. The diaphragm pressure sensing design make it more reliable than traditional float ball mechanism. Port connection design make it can sense the pressure without immersing the liquid directly.

## LF37 Order Ref NO

LF37 - 1 1 1 -4.5"-6"H<sub>2</sub>O

**A B C** Pressure setting:cut in :6"H<sub>2</sub>O ; cut off :4.5"H<sub>2</sub>O

Number	Connection Type	Contact Arrangement	Enclosure
0	/	/	none enclosure
1	<b>A</b> Diaphragm	<b>B</b> SPDT	<b>C</b> with enclosure
2	Φ6mm for tube	SPST-NO	/
3	1/4NPT	SPST-NC	/

## Specification

Model	LF37
Media	Air,water or other non-hazardous liquid
Basic function	Diaphragm Pressure switch operation:provide water level signals to appliance control,level value can be set on customer request
Pressure Range liquid level Range	2~60 in W.C.
Proof Pressure	5psi
Contact Type	SPDT,SPST-NC/NO
Electrical Rating	12/13.8A,125VAC 10A,250VAC 1/2HP;125/250VAC 3/4HP;125/250VAC
Ambition Temperature	40℃
Terminal	6.3×0.8 blade

Conversion:1mbar=100Pa 1"W.C.=249Pa

# LF40-01

Air actuated pressure switch

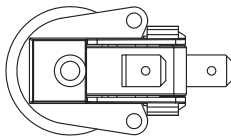
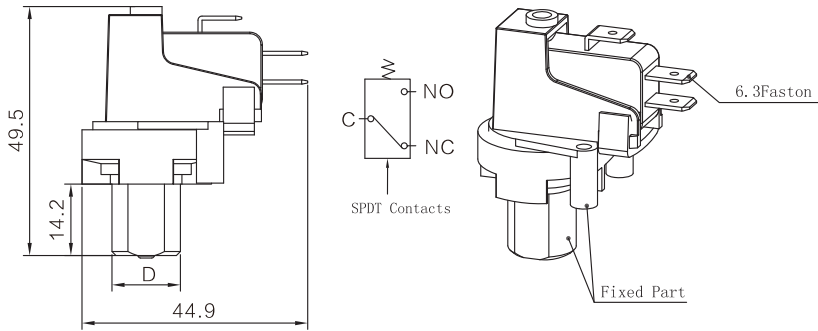

Dimension in:mm



Button

LF40 combination switch box

## LF40-01 Order Ref NO

LF40-01-1 M 13 1 -3psi

**A** | **B C D** Set Point(psi):3psi

Action Type:M=Momentary action; A=Alternate action

LF40-01 is provided with a snap action switching for higher current capacity, SPDT contact form and switch deadbands. It can be used together with air button for remote control purpose, which is widely used in food waste disposer, pumps for swimming pools and spas, hot tubs, sanitary equipment, medical equipment etc. Used as a remote control, LF40-01 has two actions, momentary action and Alternate action.

Number	Connection Type	Body Color	Electrical Rating	Terminal
1	<b>A</b> 4mm OD tube side entry	<b>B</b> white	0.1A,125/250VAC	<b>D</b> 0.25inch blade
2	4mm OD tube+NPT1/4 connection bottom entry	black	3A,125/250VAC	0.187inch blade
3	1/8NPT bottom entry	/	<b>C</b> 5A,125/250VAC	PCB
4	1/8NPT+4mm OD metal tube	/	15A,125/250VAC	/
5	/	/	16A,125/250VAC	/
6	/	/	21A,125/250VAC	/

## Specification

Model	LF40-01
Media	non hazardous gas or liquid
Operating Pressure Range	0.25~15psi for momentary action;1.0~1.8psi for Alternate action
Proof Pressure	50psi
Operating Temperature Range	-10°C to +85°C
Contact Arrangement	SPST or SPDT
Electrical Rating	0.1A,125/250VAC; 15A,125/250VAC 3A,125/250VAC; 16A,125/250VAC 5A,125/250VAC; 21A,125/250VAC
Terminal	6.3 or 4.8mm male Q.C
Connection	Inlet4.0mm for tube connection(Optional1/8"NPT or other fittings are available)

Conversion:1kgf/cm<sup>2</sup>=14.2psi 1psi=68.95mbar

# LF40-B

## Pressure switch

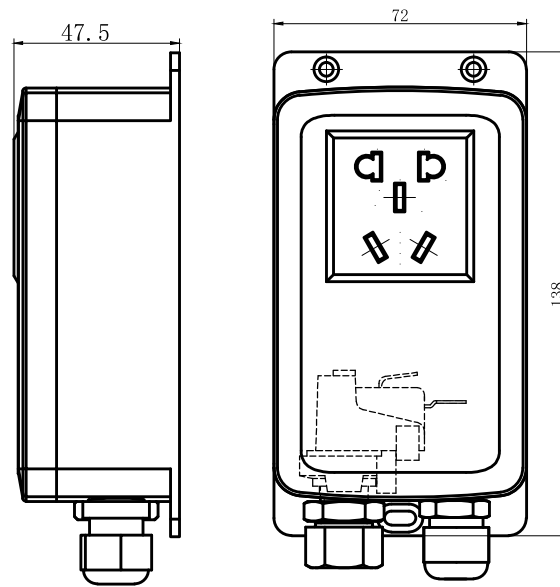

Dimension in:mm

LF40-B is provided with a snap action switching for higher current capacity, SPDT contact form and switch deadbands. It can be used together with air button for remote control purpose, which is widely used in food waste disposer, pumps for swimming pools and spas, hot tubs, sanitary equipment, medical equipment etc.

### Specification

Model	LF40-B
Good air tightness	There should be no leakage under 50 psi pressure
Pressure range	<130mbar
Service life	>40000 times
Electrical performance	10A,125/250V
Wiring form	6.3×0.8 mm blade terminal
Electrical circuit	NO-C
Operating temperature	-10°C~85°C
Socket and cable	GB, power cord length 1200mm
Air tube	Ø6 mm tube, length 1000mm

# LF40-C

Pressure switch

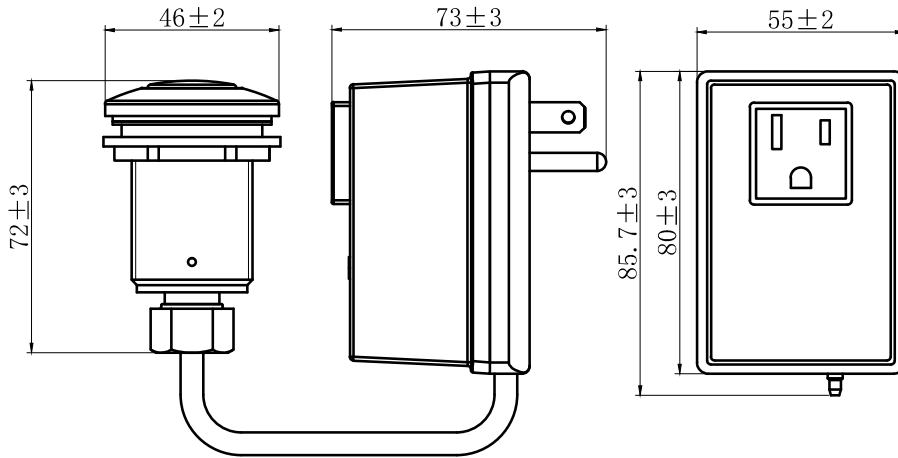

Dimension in:mm



LF40-C is provided with a snap action switching for higher current capacity, SPDT contact form and switch deadbands. It can be used together with air button for remote control purpose, which is widely used in food waste disposer, pumps for swimming pools and spas, hot tubs, sanitary equipment, medical equipment etc.

## Specification

Model	LF40-C
Action type	Alternate action
Pressure range	<130mbar
Electrical circuit	NO-C
Air tube length	Black PVC air tube length 1m
Electrical performance	8A 125VAC
Operating temperature	-10°C~60°C

# LF55

Pressure switch for Refrigeration system

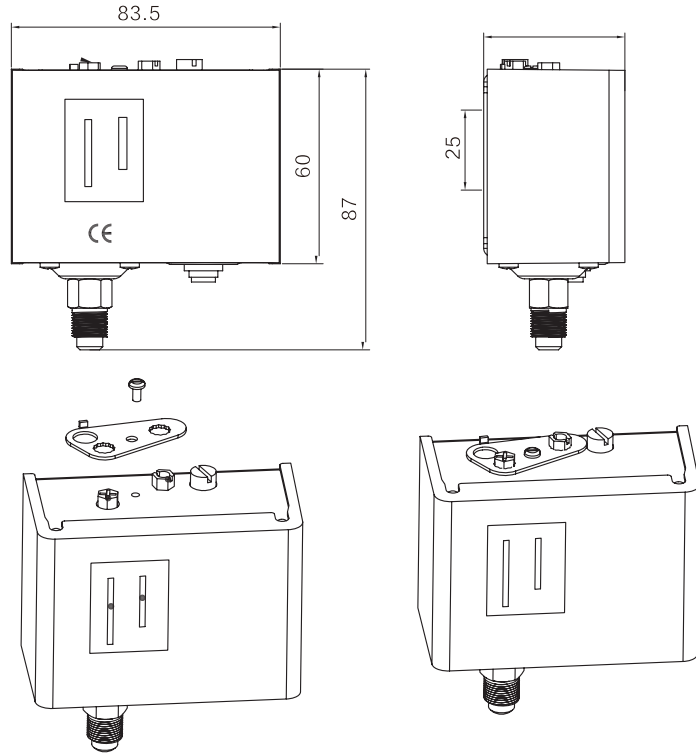
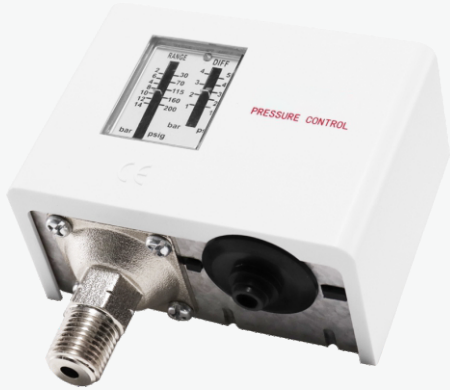

## Contact Function

Dimension in : mm

Arrow means the direction of pressure increasing, M means hand reset

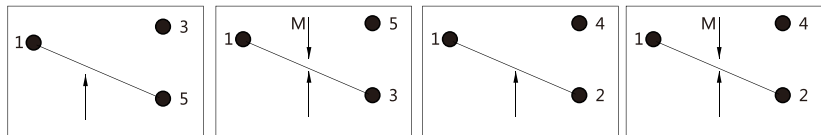

LF55 Series pressure switches are used to control the pressure of compressor in refrigerant system, also available in air or water fluid. This series have quite stable performance with internal micro-switch structure. Standard mounting bracket are provided

## Electrical Function

Rated Amps.(A)\Rated Voltage(V)	125VAC	250VAC	24VDC
Full Load	20A	10A	8A
Locked Rotor	72A	72A	64A
Temperature	-20~110°C		

## Specification

Model	Range(bar)		Differential (bar)		Factory Setting(bar)		Max Operating Pressure(bar)
	Min	Max	Min	Max	OFF	ON	
LF5502	-0.5	2	0.2	0.7	1	0.5	16.5
LF5503	-0.5	3	0.35	1.5	2	1	16.5
LF5506	-0.5	6	0.6	4	3	2	16.5
LF5506M	-0.5	6	Reset Differential ≤1bar		3	Manual Reset	16.5
LF5508	-0.2	7.5	0.7	4	3	2	20
LF5510	1	10	1	3	6	5	16.5
LF5514	2	14	1	4	10	8	20
LF5516	3	16	1	4	10	8	35
LF5520	5	20	2	5	16	13	35
LF5530	8	30	Fixed 3 to 5bar		20	15~17	35
LF5530M	8	30	Reset Differential ≤4bar		20	Manual Reset	35
LF5530D	5	30	3	10	20	15	35
LF5532	8	32	2	6	20	17	35
LF5542	8	42	4	10	30	25	46.5

Conversion: 1kgf/cm<sup>2</sup>=14.2psi 1psi=68.95mbar

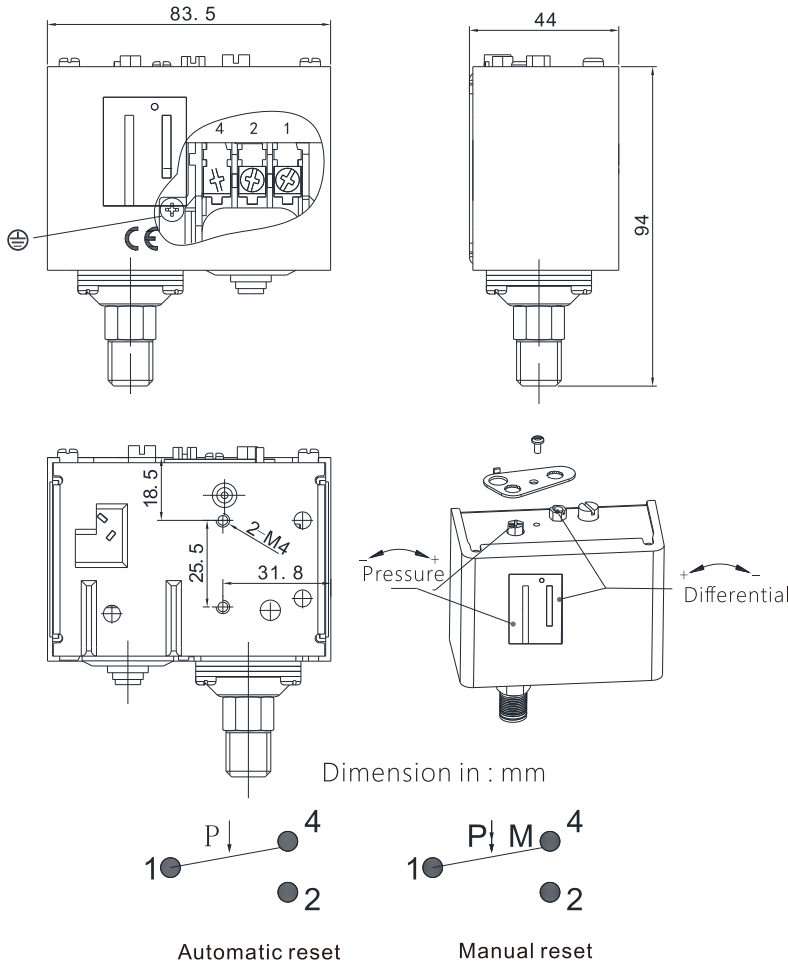

# LF55V

Vacuum pressure switch

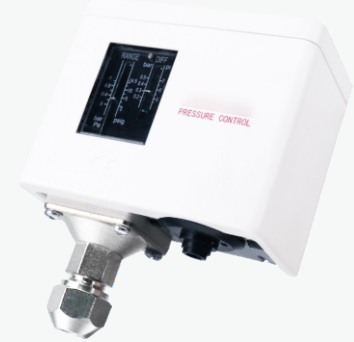

LF55V pressure controller is a kind of pressure protection device specially designed for vacuum pressure control of refrigeration or other mechanical systems to prevent the fault caused by air leakage into the system when the degree of vacuum is too low in the system. It is a kind of dynamic controller which acts by receiving the pressure signal. In the refrigeration device, when the low pressure end of the compressor is lower than the set pressure value the pressure controller will send an electrical signal to cut off the circuit and stop the compressor for safety protection. This pressure controller is not only suitable for refrigerant but also for controlling pressure of gas, water, and oil. The internal elastic structure ensures the good performance of the switch. The switch is equipped with a standard mounting bracket.

## LF55V Order Ref No.

LF55V -1 1 1 1 1-0.7/0.4

Action pressure:-0.7bar, Reset pressure:-0.4

Number	Reset Type	Connection Type	Connection specifications	Cover color	Bracket type
	Automatic reset	Male	7/16UNF(1/4SAE)	White	L bracket
	manual reset	Female	G1/4	Blue	Flat bracket
			R1/4		U bracket
			NPT1/4		None
			M12*1.25		

## Specification

General	Value
Pressure and differential range	Pressure range :-1-0bar, Differential:-0.15-0.5bar
Medium	R22/R134a/R404A/air/liquid etc
Connection material	Nickel plated copper, Other materials such as stainless steel which need to be customized.
Contact arrangement	SPDT
Electrical rating	240VAC/FL8A LR48A 120VAC/FL16A LR96A
Contact material	Moving contact: silver plated; Static contact: all silver
Environment temperature	-20~65°C
Medium temperature	-40~120°C
Protection grades	Ip20 & IP44(with bracket and cover) IP55( with protection cover)
Maximum working pressure	3bar
Voltage withstand	No Breakdown at 2000V for 1 minute
Cable interface	6-14mm diameter cable sealing interface

# LF55T

## Thermostat



CAUS  
E228961

HS  
HS GROUP

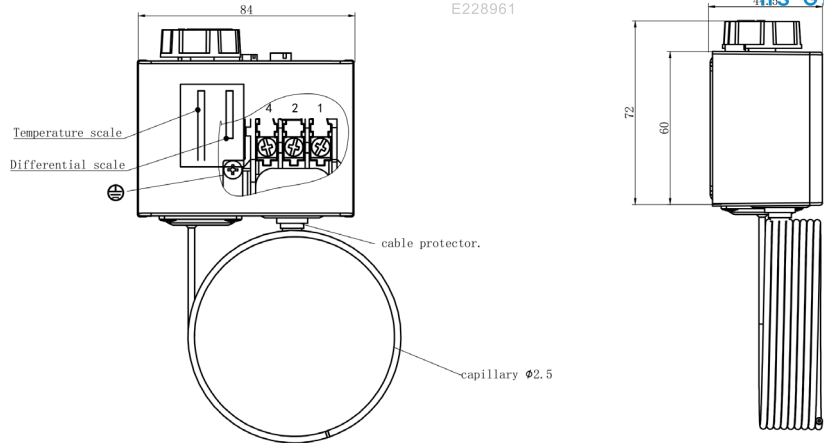

Attention 1. Pls remove the temperature adjustment knob and fixing plate before adjust the temperature.  
2. Pls fix the temperature adjustment knob and fixing plate after finishing the temperature adjustment.

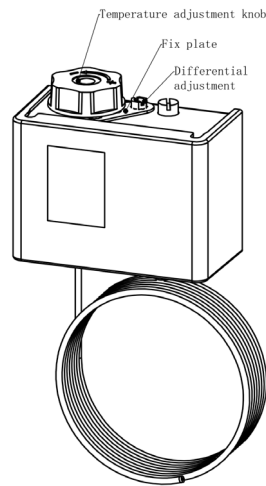

Attention 1. Low temperature protection, pls connect wire 1-4  
2. High temperature protection, connect wire 1-2

Dimension in:mm

LF55T are used for regulation, but can also be seen in safety monitoring systems. They are available with vapor charge or with adsorption charge. With vapor charge the differential is very small. The LF55T Thermostats with adsorption charge are widely used to give frost protection.

## Specification

Modle	LF55T
Contact agreement	SPDT
Electrical rating	AC15:10A,240V; DC12W,220V; Contact resistance ≤ 500mΩ
Contact material	static contact: fine silver, movable contact: Silver plated
Breakdown voltage	one min at 2000v no breakdown
Protection grade	IP 30 (IP44 when with bracket and cover)
Environment Temp	-25°C/+65°C
Media Temp	-40°C/+120°C
Mechanical lifespan	100k times
Electrical lifespan	30K times
Max installation torque	2 N/M
Capillary	Φ2.5, The minimum contacting length of the capillary and environment: 0.43m, Capillary length can be customized
Cable connection	Φ 6-14 cable

# LF58

Pressure switch for refrigeration system

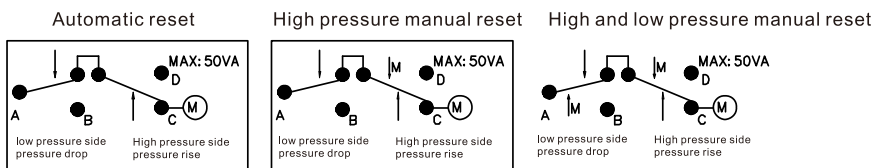
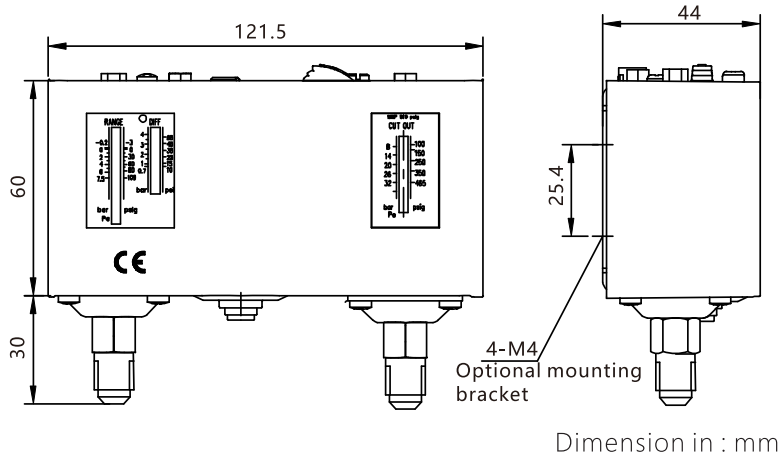

model	low pressure side			High pressure side		
	pressure range	Differential pressure range	maximum working pressure	pressure range	Differential pressure range	maximum working pressure
32	-0.2~7.5	0.7~4	17	8~32	4	35
45	2~12	1~4	17	8~45	7	48

unit: bar

LF58 pressure switch is an automatic control device that receives pressure signals and actuates. It is usually used to control the start and stop of compressors and fans in refrigeration systems. It can also be used in water pumps, fire protection, boilers, hydraulics, ironing and other devices as a safety protection.

## LF58 Order Ref NO

LF 58 -32 N A W L -3bar/2bar-20bar

Low set point High set point

model	Reset method	Protection class	Connection Type	cover color	bracket
32	None=auto reset	N=IP30	A=7/16-20male	W=white	no = no bracket
45	HM=High pressure manual reset	H=IP44	B=G 1/4male	B=Blue	P=flat type bracket
	HLM=High and low pressure manual reset	P=IP55	H=M12*1.25 male		L=L type bracket
			I=copper pipe for welding		U=U-shaped bracket

## Specification

General	Value
Medium	R22, R134a, R404A, gas, etc.
Contact method	SPDT
Electrical parameters	240VAC/FL8A LR48A 120VAC/FL16A LR72A
Contact material	Moving contact: covered with silver; Static contact: full silver
Temperature range	Ambient temperature -20~65 Medium temperature -40~120
Withstand voltage	2000V for 1 minute without breakdown
Maximum Mounting Torque	2 N·m
Cable connection	6-14mm diameter cable gland

# LF5D

## Oil differential Pressure switch

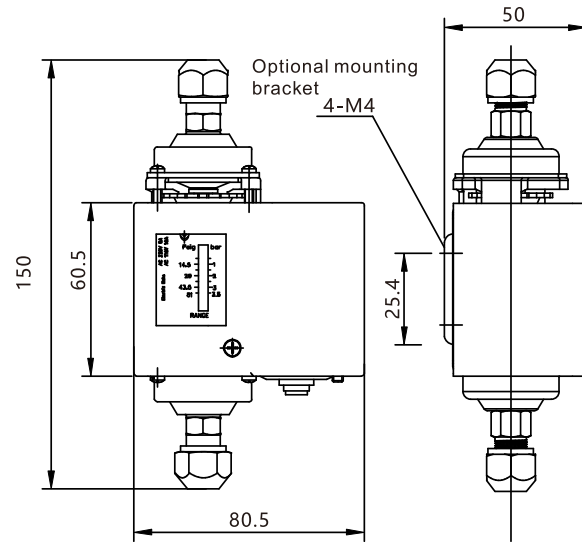

Dimension in : mm

### Auto reset

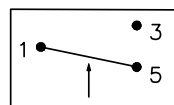

### Manual reset

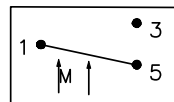

Model	Differential pressure range	Factory settings	maximum working pressure
2	0.5 ~ 2	0.5	17
4	0.5 ~ 3.5	1	17
4H	0.5 ~ 3.5	1	35
6	1 ~ 6	1	17
6H	1 ~ 6	1	35

unit: bar

The LF5D differential pressure switch is a protective device for refrigeration compressors or pressure lubrication of other mechanical. In the refrigeration system, the switch receives the two pressure signals of the discharge pressure of the lubricating oil pump and the suction pressure of the compressor, and maintains a certain range of difference between these two pressures, and when the difference is smaller than the set value, the switch will actuate immediately to automatically cut off the compressor circuit and stop the compressor, thus protecting the compressor.

### LF5D Order Ref NO

LF 5D -2 \_ \_ A W L - 1bar

set point

model	Reset method	Connection Type	cover color	bracket
2	None = auto reset	A=7/16-20male	W=white	no = no bracket
4	M=Manual reset	B=G 1/4male	B=Blue	P=flat type bracket
6		I=M12*1.25 male		L=L type bracket
4H				U=U-shaped bracket
6H				

## Specification

General	Value
Medium	R22, R134a, R404A, gas, etc.
Contact method	SPDT
Electrical parameters	240VAC/FL8A LR48A 120VAC/FL16A LR72A
Contact material	Silver contact
Temperature range	Ambient temperature -20~65°C Medium temperature -40~120
Withstand voltage	1500V for 1 minute without breakdown
Maximum Mounting Torque	2 N·m
Cable connection	6-14mm diameter cable gland

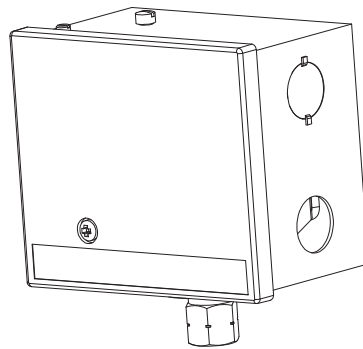
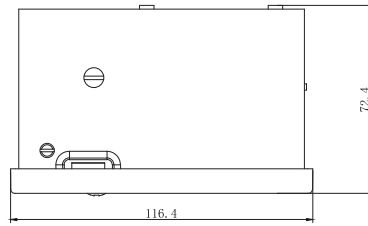
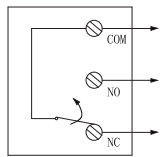
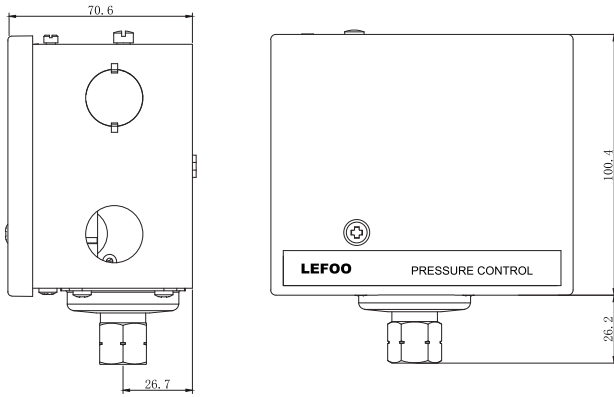

Dimension in : mm

# LF56

## Pressure switch



Model Number	Operating Ranges		Subtractive Differential		Maximum Diaphragm pressure	
	kPa	psi	kPa	psi	kPa	psi
LF5615	15-100	2-15	15-40	2-6	170	25
LF5650	35-350	5-50	40-100	6-14	590	85
LF56150	70-1035	10-150	70-150	10-22	1550	225
LF56300	140-2070	20-300	140-345	20-50	2410	350

LF56 series pressure switches are mainly used to control pressure of boiler or water tower regulating system. When the system pressure exceed the setting point, the switch will cut off the circuit for protection. With SPDT contact arrangement, LF56 switch can detect the pressure change and shift the internal status accordingly to control the on/off of external circuits, which is available for the pressure control, limit and alarm of non-hazardous liquid, gas and steam.

### Specification

MODEL	LF56
Contact arrangement	SPDT
Working media	Standard model for oil, water, air, steam, liquid and other non-corrosive media, chlorine-containing liquids are not available.
Ambient temperature	-29°C~66°C
Media Temp	-40°C~180°C non-frozen condition
Pressure Diaphragm	stainless steel
Thermal Material	brass
Connection	NPT1/4、G1/4、R1/4
Electrical Rating	FLA 5.1A/240VAC, 8.0A/120VAC; LRA:30.6A/240VAC, 48.0A/120VAC

# LF52

## Differential Pressure switch



Installation dimension (mm)

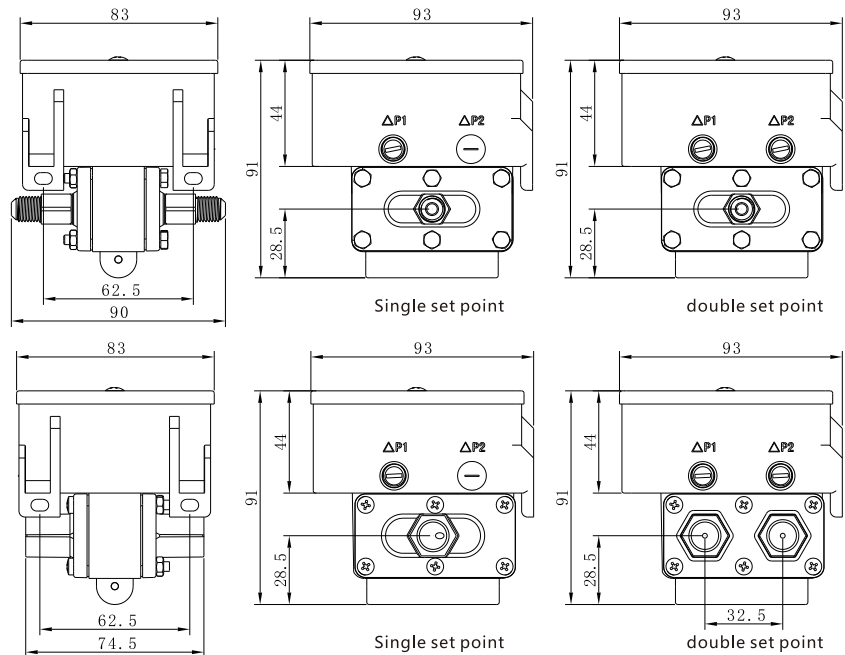

Wiring diagram

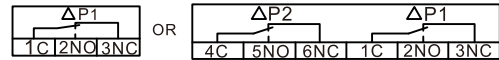

Product introduction:

This adjustable differential pressure switch LF52 is developed for sparingly using in different differential value requirements. It is widely applied for detecting the differential of water filter, pump, heat exchanger, chillers and its coil units. When the water flowing (differential) decrease or increase to the setting point, there will be an alarm or cut off output signal for the self-controlling system. It's also available for indicating the status of pump or water filter. Double differential settings pressure switch can take the replacement of the vane flow switch and avoid changing the vane flow switch from chillers each year.

A single set point is a high/low limit that controls the differential pressure between the front and rear ends of a section of pipeline. The double set point is to control the high and low limit of the pressure difference between the front and rear ends of a pipeline, and can also control the high/low limit of the pressure difference between the front and rear ends of the two pipelines.

Reference standard:

- 1.U1508
- 2.GB14048-2000 ( Low voltage switchgear and control equipment general provision )
- 3.GB14048.5-2000(Low voltageswitchgear and control equipment, part 5-1 Control equipment and switching elements )
- 4.ROHS certificate.

Adjustable	Model	Differential pressure adjustable range kPa	Differential	Lap increment
Single Set Point Working Pressure range	52-15	5—15	3±1	1
	52-30	5—30	3±1	2.2
	52-70	6—70	3±1	5.5
	52-100	6—100	5±1	6.5
	52-200	10—200	6±1.5	16
	52-300	20—300	7±1.5	25
Dual Set Point Working Pressure range	52-400	30—400	8±1.5	38
	52-30/100	5—30/6—100	3±1/5±1	2.2/6.5
	52-70/100	6—70/6—100	3±1/5±1	5.5/6.5
	52-100/100	6—100/6—100	5±1/5±1	6.5/6.5
	52-100/200	6—100/10—200	5±1.5/6±1.5	6.5/16
	52-200/200	10—200/10—200	6±1.5/6±1.5	16/16
	52-300/300	20—300/20—300	7±1.5/7±1.5	25/25
	52-400/400	30—400/30—400	8±1.5/8±1.5	38/38

LF52Series Order Ref NO LE52- - -

Product set point	Joint thread	Instructions	Wiring protection
Single set point	7/16"UNF single connector(Male thread)	Chinese/English	rubber Gland Pg16
Double set point	G1/4 single connector(female thread)	Chinese	plastic Gland Pg16
	G1/4 double connector (female thread)	English	nickel plated at brass Gland Pg16

### Specification

Media	Non hazardous media such as water, air, oil etc...
Contact arrangement	One/two sets of SPDT (microswitch)
Electrical rating	3A 250VAC 5A 125VAC
Storage temperature	-29~82°C
Ambient temperature	-20~71°C(fluid)
Media temperature	-20~93°C(fluid)
High and low pressure connections	7/16"UNF single connector(Male thread) ;G1/4 single connector(female thread); G1/4 double connector (female thread)
Maximum static pressure	16bar
Maximum differential	10bar
Setting repeatability tolerance	±1%
Degree of protection	Ip54
Accessories are optional (if there is no requirement, the default is selected)	Converted capillary, plastic/metal/rubber/line card, manual in Chinese/English

# LF52A

## Differential Pressure switch

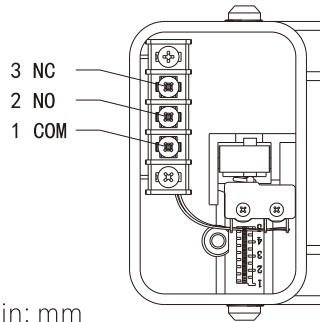
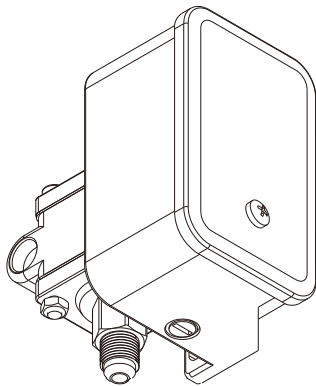
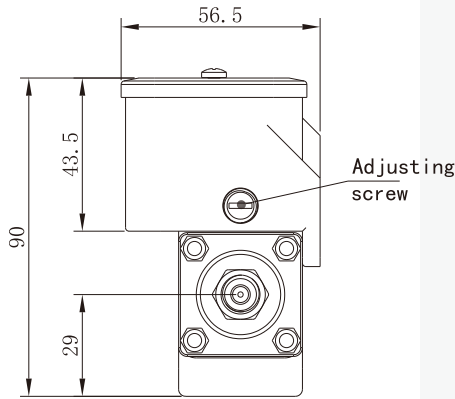
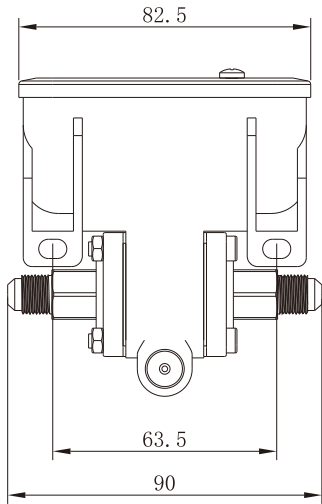

Dimension in: mm



(1) Product overview:

LF52A series pressure switch is an adjustable differential pressure switch.

It is developed for applications that are used in small quantities and have different requirements for differential pressure values. It is an alternative to paddle flow switches. Avoid the disadvantage that the chiller needs to replace the paddle flow switch every year. When the water flow (differential pressure) in the system rises or falls to the set value, it will output an alarm or cut-off signal to the automatic control system.

The unique small size of LF52A can cope with various narrow installation environments. At the same time, take into account the quality and reliability, and give full play to the product performance. It is widely used in engineering to detect the pressure difference of water filters, pumps, heat exchangers and other chillers and coils. Can also be used to indicate the status of a pump or water filter.

(2) Reference standard:

1. UL508
2. GB14048-2000 "General Rules for Low-Voltage Switchgear and Control Equipment";
3. GB14048.5-2000 "Low-voltage switchgear and control equipment - Part 5-1 Control electrical appliances and switching elements - Electromechanical control circuit electrical appliances"
4. ROHS certification

Adjustable	Model	Differential pressure adjustable range kPa	Return difference kPa	One turn variation kPa
working pressure	52A-15	5—15	3±1	1
	52A-30	5—30	3±1	2.2
	52A-70	6—70	3±1	5.5
	52A-100	6—100	5±1	6.5
	52A-200	10—200	6±1	16
	52A-300	20—300	7±1	25
	52A-400	30—400	8±1	38

### LF52A Series Order Ref NO

LF52A-30-1-1-1-1-15kpa

setpoint

Code	Connector Material	Connector Thread	Instruction Manual	Wiring Protection
	Brass	7/16"UNF FEMALE	Chinese and English	Plastic Gland PG16
	SS 316L	7/16" UNF MALE	Chinese	Brass Nickel Plated Gland PG16
		R1/4" MALE	English	
		G1/4" MALE		
		1/4"NPT MALE		
		connect φ8 soft tube		
		connect φ6 steel pipe		

### Specification

Medium	Water,air,oiland other non-corrosive medium
Contact	Single group SPDT (microswitch)
Electrical Specifications	3A 250VAC 5A 125VAC
Storage temperature	-29~82°C
Ambient temperature	-20~71°C
Medium temperature	-20~93°C(fluid)
Maximum allowable static pressure	16bar
Maximum allowable differential pressure	10bar
Set point repeatability deviation	±1%
Protection class	IP54
Accessories are optional (default if not required)	Converted capillary

# FS5 Series

## Liquid flow switch



FS51

FS52

FS series liquid flow switch is designed for managing the flow changes when the liquid flows in the pipe, such as water, ethylene glycol or other non-hazardous liquids. When the liquid flow is higher or lower than the setting value, the single-pole double-throw contacts (SPDT) can get through one circuit and at meantime to break the other circuit. FS series liquid flow switch is commonly used for chain reaction or "no flow" protection.

### Specification (FS flow switch)

### Features

- Max liquid pressure: 1 MPa, can be used in multiple applications.
- There are 3 stainless steel paddles, can be used in 25 to 75mm diameter pipe.
- Number of paddles is changeable and length of paddle is trim-able according to customer requirements.
- With additional 6"paddle, FS series liquid flow switch can be used in 100 to 150mm diameter pipe.
- Adjustable flow setting, Users can set the flow value according to their requirements.
- For user convenience, FS52 flow switch has large room for wiring.
- FS51/FS52 can also be provided with stainless steel connection, which is suitable for ammonia and other medium.

### Application

The typically application is used to protect the cooling system, when the cooling water is off, FS flow switch can shut off the compressor current efficiently in order to protect the freezer and entire system from being damaged.

### Performance Parameter

- Electric load: AC250V 10A
- Max working pressure: 10.34Bar
- Flow temperature: 0-120°C
- Environment temperature: 0-60°C
- The endurance of bellows: 500000 cycles
- Ingress protection: IP53

		Actuate flow (m <sup>3</sup> /h)													
Pipe Diameter (mm)		25	32	40	50	65	80	100	125	150	200	100*	125*	150*	200*
Min Adjust ment	Flow increase (red blue closed)	0.95	1.32	1.70	3.11	4.09	6.24	14.8	28.4	43.2	85.2	8.4	12.9	16.8	46.6
	Flow decrease (red yellow closed)	0.57	0.84	1.14	2.16	2.84	4.32	11.4	22.9	35.9	72.7	6.13	9.31	12.26	38.6
Max Adjust ment	Flow increase (red blue closed)	2.0	3.02	4.36	6.6	7.84	12.0	29.1	55.6	85.2	172.6	13.4	26.8	32.7	94.26
	Flow decrease (red yellow closed)	1.93	2.84	4.09	6.13	7.23	11.4	27.7	53.4	81.8	165.8	17.3	25.21	30.66	90.85

- Above flow values are for the reference of choice
- The figures with "\*" symbol are for the 4 paddles flow switch. While, the figures without "\*" symbol are for the 3 paddles (1, 2, 3) flow switch.
- The paddles will be chose according to the flow in the main pipe where the flow switch is installed in.

### Installation

- Pipe connection: FS series flow switch be provided with 1", 1/2", 3/4" NPT connections.
- The arrow direction in the cover must be as same as the flow direction in the pipe.
- The flow switch is suggested to be installed on horizontal pipes, if it have to be on vertical pipes, then the direction in the pipe must be upward flow. It is not allowed to be installed on the vertical lines with downward flow.
- To avoid the paddle damage, flow reversal is not allowed when the flow switch is working.

## The paddle trimming figure

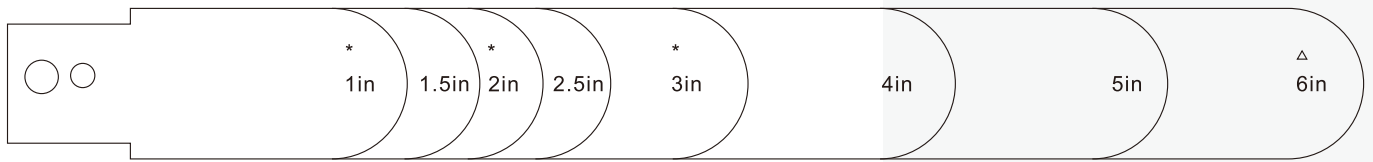

## Attention

- the paddles with " \* " symbol are installed in factory
- the paddle with " Δ " symbol is the additional paddle.(not installed)
- the balance paddles are for trimming
- when install the trimmed paddles, the end of paddle should keep 5--10mm distance from the pipe end and no friction with the pipe

## Order Ref No.

FS51/FS52 - 1 1

- Connection Material: Brass
- Connection size: 1"NPT

Code	Connection size	Connection Material
1	1"NPT	Brass (for water or other liquids suitable for brass)
2	1/2"NPT	Stainless steel (for ammonia and other liquids suitable for stainless steel)
3	3/4"NPT	

## Wiring diagram

Switch actuate, when the flow increasing and exceed the setting value

Common terminal

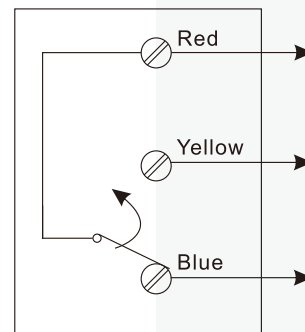

Switch actuate, when the flow decreasing and exceed the setting value

Common terminal

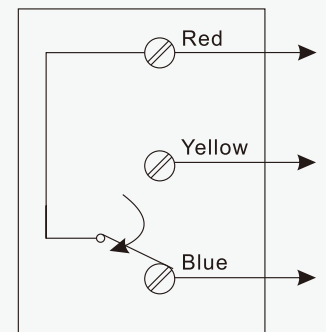

Range adjusting screw

## Typical installation drawing

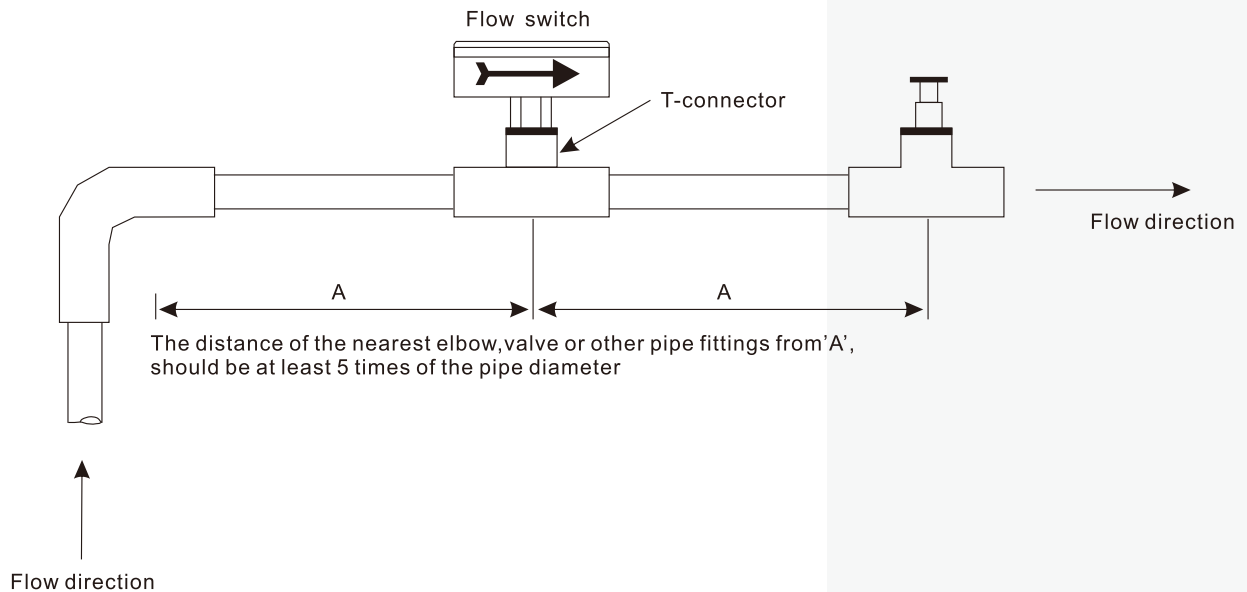

# FS200Series

Liquid Flow Switch



FS201



FS202



FS203

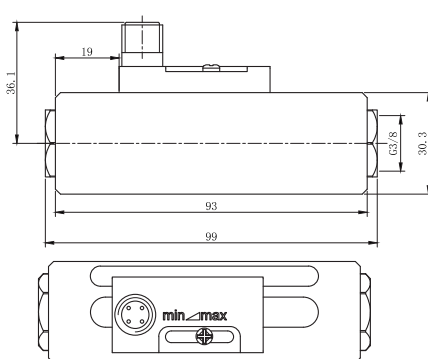

FS201

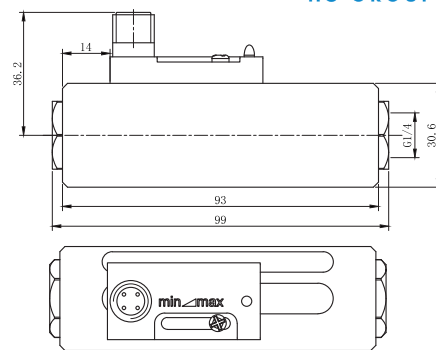

FS202

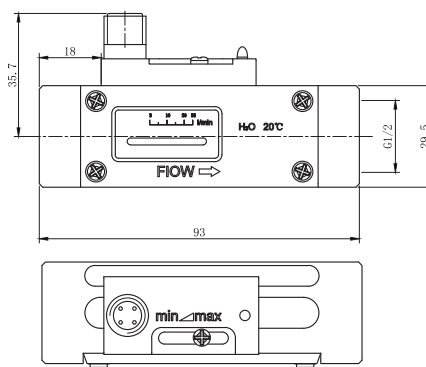

FS203

## Principle and Structure

Online installation, mechanical flow switch, Be used in liquid or gas media. Solid plastic, aluminum or stainless steel housing are optional.

## Main Feature

Very few pressure loss, satisfactory repeatability and anti-pollution, mechanical and electronic parts are isolated completely. More accurate setting accuracy, with setting dial gauge, easy setting, user no need to set on site, switch status displays in LED.

## Application

Can be used in both gas and liquid, industrial automation, mechanical equipment, air compressor industrial, HVAC.

## Order Ref No

FS201(202 203)- 2 1 1 3 1 1

A B C D E F

code	Pipe Diameter	Connection	Distributing Detail	Materials	Alarm setting range	Electrical Connection
1	Thread connection G1/4	B Female thread	C DC distributing 24V±20%DC	POM reinforced plastics	E 0.6~8L/Min (Lower limited alarm :0.1~7L/Min)	M12 plug
2	A Thread connection G1/2	/	AC distributing 230V±15%AC	Anodic Aluminum Oxide Materials	1~15L/Min	Hirschmann plug
3	Thread connection G3/8	/	/	D 304 stainless steel	2~28L/Min	/
4	Thread connection G3/4	/	/	/	27~70L/Min	/
5	Thread connection G1	/	/	/	/	/

# Specification

General	Value
Setting Range	See Specification Sheet
Accuracy	±5% total range
Delay	Depend on different switches, Minimum 0.5L/Min
Setting Scale	20°C water as media, horizontally installation in marked position Change of media and temperature can influence the value
LED display	Only available in DC distributing
Terminal	M12 and Hirschmann plug
Output	Reed switch capacity:24VDC/250VAC,100mA
Proof Pressure	50bar(aluminum) 200bar(stainless steel)
Average Pressure Loss	0.3bar(25L/min)
Return Difference	Related to the switch value,minimum 0.5L/Min
Temperature of media	0-100°C/0-160°C(high temperature option)
Protection Degree	IP65
Engineering plastics materials	Housing:POM engineering plastics
	Plunger:POM engineering plastics
	Spring:316L stainless steel SUS1.4310
	Seal:NBR
Anodic Aluminum Oxide Materials	Magnet:Barium
	Housing:Anodic Aluminum Oxide
	Plunger:POM engineering plastics
	Spring:316L stainless steel SUS1.4310
Stainless Steel Materials	Seal:NBR
	Magnet:Barium
	Housing:304 stainless steel
	Plunger:POM engineering plastics
Stainless Steel Materials	Spring:316L stainless steel SUS1.4310
	Seal:NBR
	Magnet: Barium
	Housing:304 stainless steel

## Specification

	Model	Proof Pressure	Maximum Flow	Changeable range	G	L	H	B	X	Weight		
		Kg	L/min(water)	L/min(water)	mm	mm	mm	mm	mm	Kg		
Anodic Aluminum Oxide Materials (stainless steel)	FS201, 202, 203	Max inmun 200 Kg	40	0.6(0.1) 8(7)	G1/4	93	36	30	15	12	0.22 (0.53)	
				0.6(0.1) 8(7)	G3/8					0.20 (0.51)		
				0.6(0.1) 8(7)	G1/2					0.18 (0.48)		
				0.6(0.1) 8(7)	G3/4	105				35	0.23 (0.65)	
				0.6(0.1) 8(7)	G1	105				40	0.32 (0.82)	
				1(0.5) 15(13)	G1/4	93				30	12	0.22 (0.53)
				1(0.5) 15(13)	G3/8			0.20 (0.51)				
				1(0.5) 15(13)	G1/2			0.18 (0.48)				
				1(0.5) 15(13)	G3/4			105	35			0.23 (0.65)
				1(0.5) 15(13)	G1			105	40			0.32 (0.82)
				2(0.8) 28(25)	G1/2			93	30			15
				80	2(0.8) 28(25)	G3/4		105	35	0.23 (0.65)		
			2(0.8) 28(25)		G1	40	0.32 (0.82)					
			120		27(21) 70(66)	G3/4	35			15	0.23 (0.65)	
				27(21) 70(66)	G1	40		0.32 (0.82)				

Remark:

1. Data in above parentheses is reset point while the other is operating point, Please refer to reset point data while in lower limit alarm(monitored too small flow), and refer to operating point data while in upper limit alarm(monitored too large flow)
2. Above data is based on the test that switch is installed on horizontal pipe vertically and use 20°C water as media.
3. Above proof pressure data is based on 304 stainless steel materials, proof pressure 50bar,20bar are optional either.

# FS211

## Electronic flow switch



### Principle Structure:

There are two resistors in the enclosed probe based on the thermal principle. One of them is heated as the detection resistor and the other is not heated. As the reference resistance, when the medium flows, the heat on the heating resistor is taken away. The resistance value is changed, the two resistance differences are used as the basis for judging the flow rate.

### Features:

No moving parts, maintenance-free, easy to install, one type can meet a variety of diameter requirements. Switching value is continuously adjustable, very low pressure loss, compact structure, LED display flow trends and switch status.

### Application:

Gas-liquid dual-use type, used for pneumatic and hydraulic systems, circulating water, cutting fluid and lubricating oil flow monitoring, and pump idling protection.

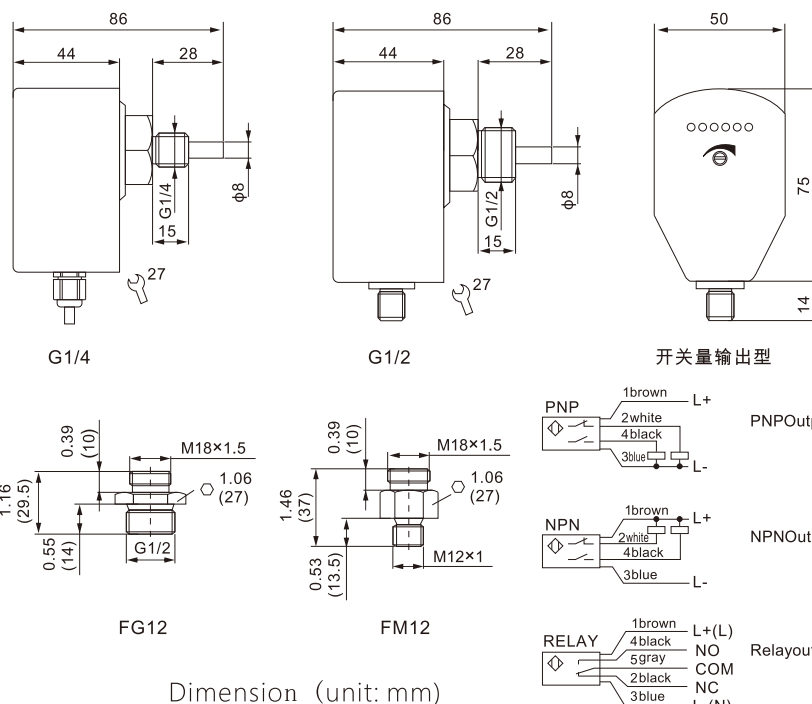

### FS211 Order Ref No

FS211-G2-H-D-P-R-Q

Pressure Connection	Connection Type	Power Supply	Output	Output method	Connector Type
G2=G1/2	H=Male	D=VDC24V±20%Power Supply	P=PNP Output	R=NO+NC Output	Q=Socket Connector Type
G4=G1/4			N=NPN Output		
			C=Relay output		

### Socket Connector Order Ref No

ST04-PU-02-F-G

Note: The relay type products need to use 5-pin connector, type and core connector, Just change S (E) T04 to S (E) 05

Socket Connector	Material	Line length	Female plug	Shape
ST04=M12	PU=PUR	02=2M	F=F	G=Straight type
ET04=M12		05=5M		W=Curved type
		10=10M		

### Specification

Setting Range	1...150cm/s(Water),3...300cm/s(Oil), 20...2000cm/s(Gas)	Initialization time	About 8s
Signal output	PNP, NPN, Relay Type, NO+NC	Electrical protection	Reverse, short circuit, overload protection
Power Supply	24V±20%DC or 230V±15%DC	Protection level	IP67
Turn on current	Max 400mA(PNP, NPN); Max 4A (Relay Type)	Medium temperature	-20~80°C
No-load current	Max 80mA	Ambient temperature	-20~80°C
Flow indication	LED (6pcs)	Storage temperature	-20~100°C
Setting Type	Potentiometer Setting	Connection mode	M12 Socket Connector/Attached 2 meters optional
Proof Pressure Range	100bar	Material	Probe: stainless steel; Housing: PBT
Medium temperature change	≤4°C/s	Weight	About 0.4kg
Response time	1--13s, Typical value 2s		

# FS213

## Electronic flow switch

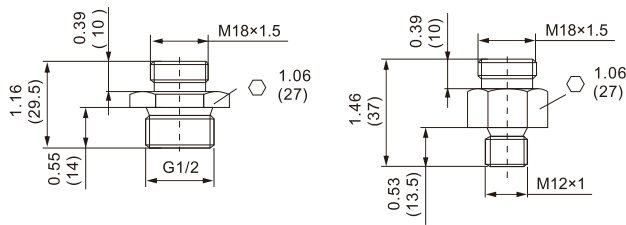
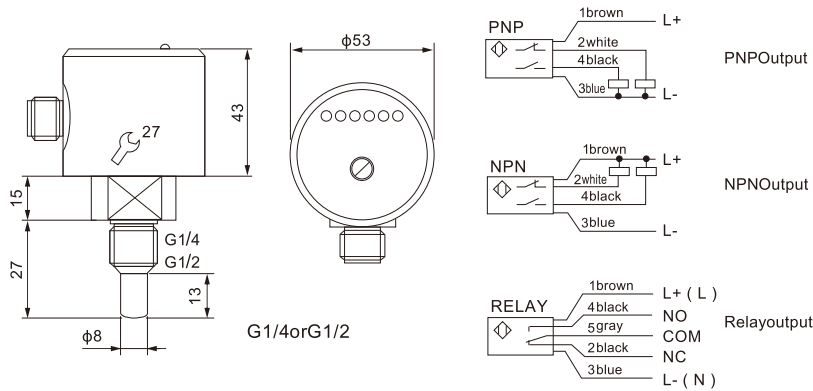

Dimension (unit: mm)

### Principle、Structure:

There are two resistors in the enclosed probe based on the thermal principle. One of them is heated as the detection resistor and the other is not heated. As the reference resistance, when the medium flows, the heat on the heating resistor is taken away. The resistance value is changed, the two resistance differences are used as the basis for judging the flow rate.

### Features:

No moving parts, maintenance-free, easy to install, one type can meet a variety of diameter requirements. Switching value is continuously adjustable, very low pressure loss, compact structure, LED display flow trends and switch status.

### Application:

Gas-liquid dual-use type, used for pneumatic and hydraulic systems, circulating water, cutting fluid and lubricating oil flow monitoring, and pump idling protection.

### FS213 Order Ref No

FS213-G2-H-D-P-R-Q

Pressure Connection	Connection Type	Power Supply	Output	Output method	Connector Type
G2=G1/2	H=Male	D=VDC24V±20%Power Supply	P=PNP Output	R=NO+NC Output	Q=Socket Connector Type
G4=G1/4			N=NPN Output		
			C=Relay output		

### Specification

Setting Range	1...150cm/s(Water),3...300cm/s(Oil), 20...2000cm/s(Gas)	Initialization time	About 8s
Signal output	PNP, NPN, Relay Type, NO+NC	Electrical protection	Reverse, short circuit, overload protection
Power Supply	24V±20%DC	Protection level	IP67
Turn on current	Max 400mA(PNP, NPN); Max 1A@24V ac/dc (Relay Type)	Medium temperature	-20~80°C
No-load current	Max 80mA	Ambient temperature	-20~80°C
Flow indication	LED (6pcs)	Storage temperature	-20~80°C
Setting Type	Potentiometer Setting	Connection mode	M12 Socket Connector
Proof Pressure Range	100bar	Material	Probe: stainless steel; Housing: stainless steel
Medium temperature change	≤4°C/s	Weight	About 0.4kg
Response time	1--13s, Typical value 2s		

# TS

## Temperature controller



TS series temperature controller can be directly connected to single phase motor under 1KW, or installed in controller circuit of DC motor and large AC motor. TS series temperature controller can match with solenoid valve to control the temperature of the refrigerator. TS series temperature controller is equipped with a SPDT double throw switch. The switching points depend on the setting value of temperature controller and temperature thermometer bulb sense.

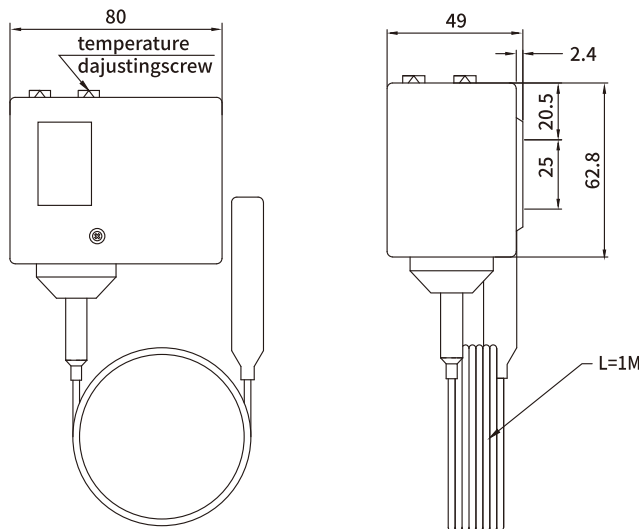

Dimension (unit: mm)

sense.

### Specification

Model	Adjusting range (°C)	Factory settings (°C)		The highest temperature of thermo-bulb (°C)	Dimension of thermo-bulb (mm)		Working conditions (°C)
		ON	OFF		Length	Diameter	
TS70	-70~-30	-50	-45	45	80	10	TS>TB
TS30	-30~0	-19	-14				
TS15	-15~15	-5	0				
TS40	0~40	17	20	70	120	12	ALL
TS90	40~90	55	60	120			
TS120	70~120	90	95	130			

Note: 1.TS -bulk temperature, TB-the temperature thermo-bulb sense

2.The length of the standard capillary is 1m.

Environment temperature: -20~70°C different length can be customized.

Wire Connection: Diameter 15mm cable gland.

### Electrical Ranting

Rated Voltage (V)		A.C.110		A.C.220	
		Rated Current (A)		Rated Current (A)	
Non-induced current		20A		10A	
Induced current	Full load current	15A		8A	
	Instantaneous current	72A			

### Contact Form

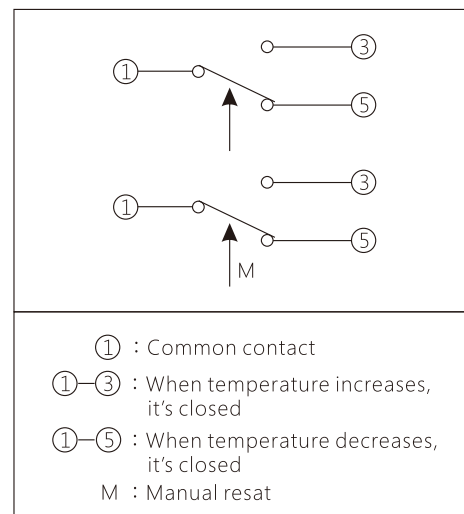

# TSD

## Differential temperature controller

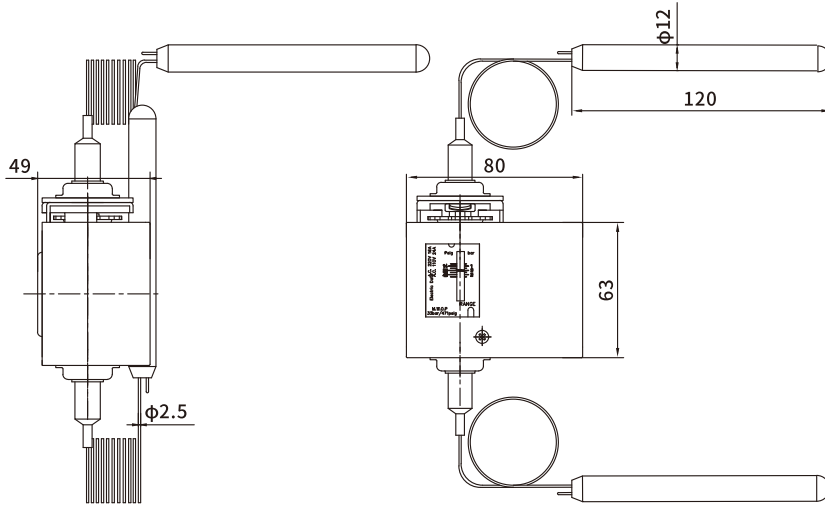

Dimension (unit: mm)



TSD is differential temperature controller has two thermo-bulbs to sense the differential temperature. After comparing the differential temperature with the setting value, the differential temperature controller will putout a differential signal to make the temperature controller work. The differential temperature controller can keep a constant value of differential temperature between two medium in general ventilation and some cooling devices. The two relative thermo-bulbs, one is for temperature reference, the other one is for controlling signals. Differential temperature is directly controlled parameters.

### Specification

Model	Differential temperature setting range	Setting the action differential temperature of the Min. differential temperature	Working temperature range	The highest temperature of thermo-bulb
TSD40	0℃~15℃	≤3℃	-25℃~40℃	60℃
TSD100	5℃~25℃	≤5℃	20℃~100℃	150℃

Environment temperature: -20~70

Wire connection: Diameter of wire entrance hole: 15mm

### Contact Form

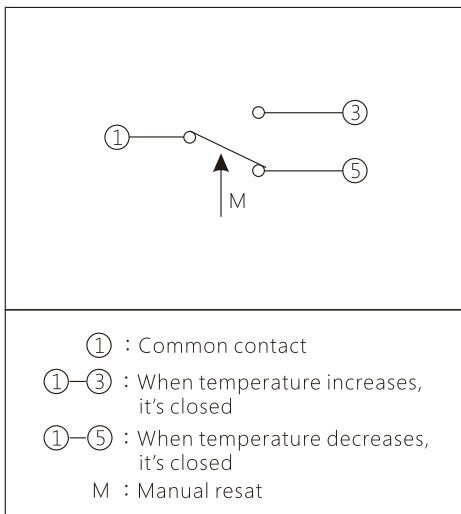

### Electrical Ranting

Rated Voltage (V)		Rated Current (A)		
		A.C.110	A.C.220	
Induced current	Non-induced current		20A	10A
	Full load current		15A	8A
	Instantaneous current		72A	

# TSH

## Dual temperature controller

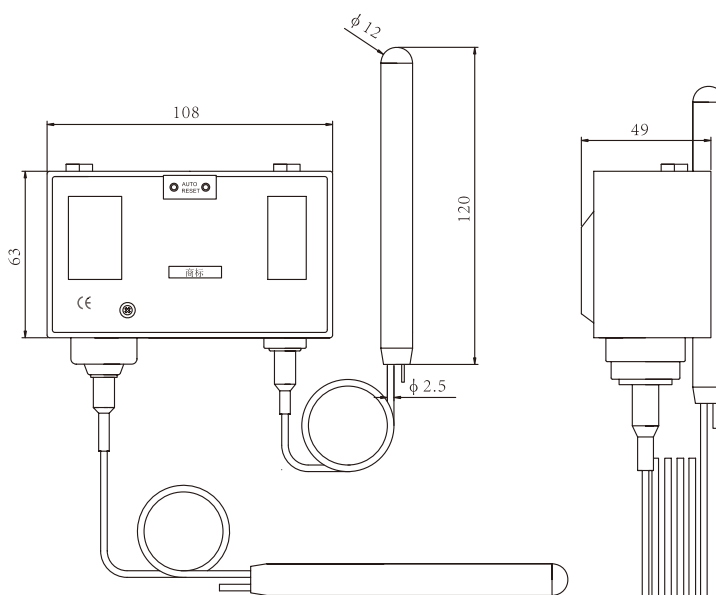

Dimension (unit: mm)

TSH is dual temperature controller with two independent temperature control functions. It's used in refrigeration equipment to prevent high temperature of compressor's discharge, at the same time to ensure proper temperature of compressor oil. One of high temperature thermo-bulb(HT) is put in pipe of compressor discharge, another one(OIL) is in compressor's oil sump. Protective shutdown will be performed when any one of thermo-bulbs is over temperature limit.

### Specification

Model	Low side			High side		
	Temperature setting range	Differential temperature adjustable range	The highest temperature of thermo-bulb	Temperature setting range	Differential temperature adjustable range	The highest temperature of thermo-bulb
TSH160	50°C ~110°C	10°C ~30°C	130°C	80°C ~160°C	≤15°C	180°C
TSH160HM	50°C ~110°C	10°C ~30°C	130°C	80°C ~160°C	Manual reset	180°C
TSH160LHM	50°C ~110°C	Manual reset	130°C	80°C ~160°C	Manual reset	180°C

Environment temperature: -20~70

Wire connection: Diameter of wire entrance hole: 15mm

### Electrical Rating

Rated Voltage (V)		A.C.110		A.C.220	
		Rated Current (A)		Rated Current (A)	
Non-induced current		20A		10A	
Induced current	Full load current	15A		8A	
	Instantaneous current	72A			

### Contact Form

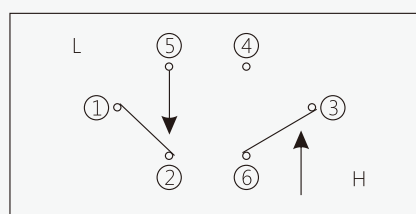

TSH160

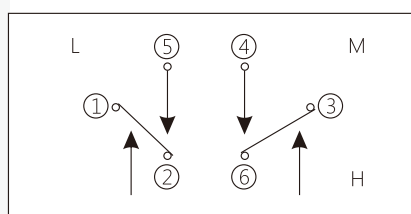

TSH160HM

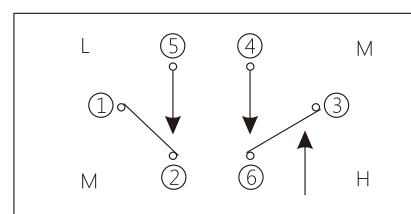

TSH160LHM

# LFS-01

Miniature pressure & vacuum switch

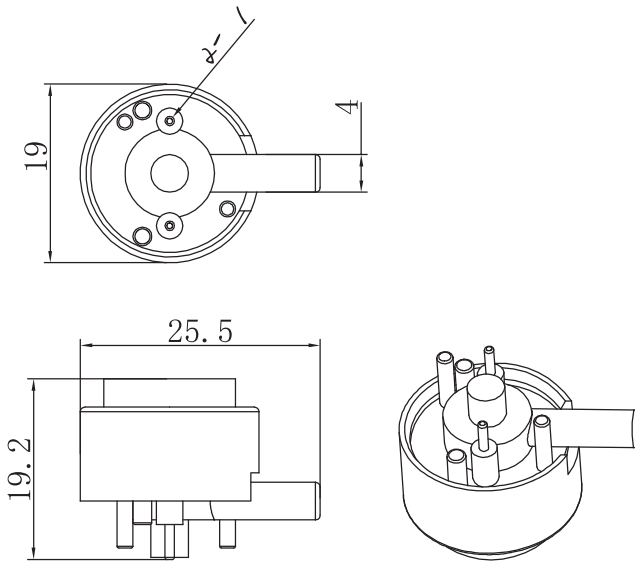

Dimension in:mm



## LFS-01 Order Ref NO

LFS -01 0 0 0 W10 R135 - V90  
**A B C D E F**

- A Connection Type:**D=Pressure & Vacuum Connection ; 0=Vacuum Connection
- B Contact Carrying parts:**0=Brass Silver Plated ; G=Brass Golden Plated
- C Connection Size:**0=4mm OD tube
- D Wire Lead:**0=Without,Wxx=Length of wire lead in inches,i.e.W10=10inch wire lead;Terminal is available on customer's request
- E Inlet Rotation:**0=Aligned,Rxx=Angle(xx in Degrees) i.e.R135=135°
- F Pressure setting in mbar:** i.e. V90=90mbar vacuum, P90=90mbar positive

## Specification

Model	LFS-01
Media	Non-hazardous gas only
Electrical Function	1 pole NO
Electrical Rating	20mA,125/250V~
Ambient Temperature	-10°C to +90°C
Electrical Connection	solder pins 1.0mm,10mm between away from each other or with different leads and terminals
Pressure Range	Pressure:10-800mbar; Vacuum: 10-800mbar
Maximum Pressure	1000mbar
Connection	Inlet 4.0mm for tube connection

Conversion:1mbar=100Pa

negative and positive pressure, such as the family vacuum cleaner. The switch have many electrical connection type, such as different wire leads, terminals, socket and solder pin connection(special design for the installation of Printed Circuit Boards). It is designed as an economical interface between pressure systems and Printed Circuit Boards with no delay nearly.

# LFS-02

Miniature pressure & vacuum switch

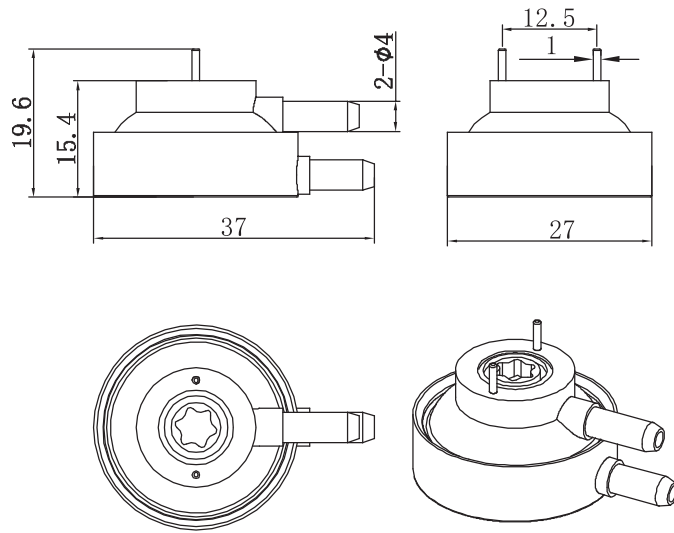

Dimension in:mm

LFS-02 Pressure Switch is designed as an economical interface between pressure systems and Printed Circuit Boards. This switch can be used as a gauge or differential pressure switch with almost no hysteresis. It is applied to detection both positive and negative pressure. Features of this switch include a body design that allows the pressure ports to be rotated, various terminal styles including wire leads.

## LFS-02 Order Ref NO

LFS-02 0 0 0 W10 R135 - V90  
**A B C D E F**

**A Connection Type:**D=Pressure & Vacuum Connection ; 0=Vacuum Connection

**B Contact Carrying parts:**0=Brass Silver Plated ; G=Brass Golden Plated

**C Connection Size:**0=4mm OD tube ; B=5mm OD tube

**D Wire Lead:**0=Without,Wxx=Length of wire lead in inches,i.e.W10=10inch wire lead;Terminal is available on customer's request

**E Inlet Rotation:**0=Aligned,Rxx=Angle(xx in Degrees) i.e.R135=135°C

**F Pressure setting in mbar:**i.e. V90=90mbar vacuum, P90=90mbar positive

## Specification

Model	LFS-02
Media	Non-hazardous gas only
Electrical Function	1 pole NO
Electrical Rating	250mA,250V~
Ambient Temperature	-10°C to +90°C
Electrical Connection	solder pins 1.0mm,12.5mm between away from each other or with different leads and terminals
Pressure Range	Pressure:5-800mbar; Vacuum:5-800mbar
Maximum Pressure	Pressure: 1000mbar; Vacuum:1000mbar
Connection	Inlet 4.0mm or 5.0mm for tube connection

Conversion:1mbar=100Pa

# LFS-03

Miniature pressure & vacuum switch

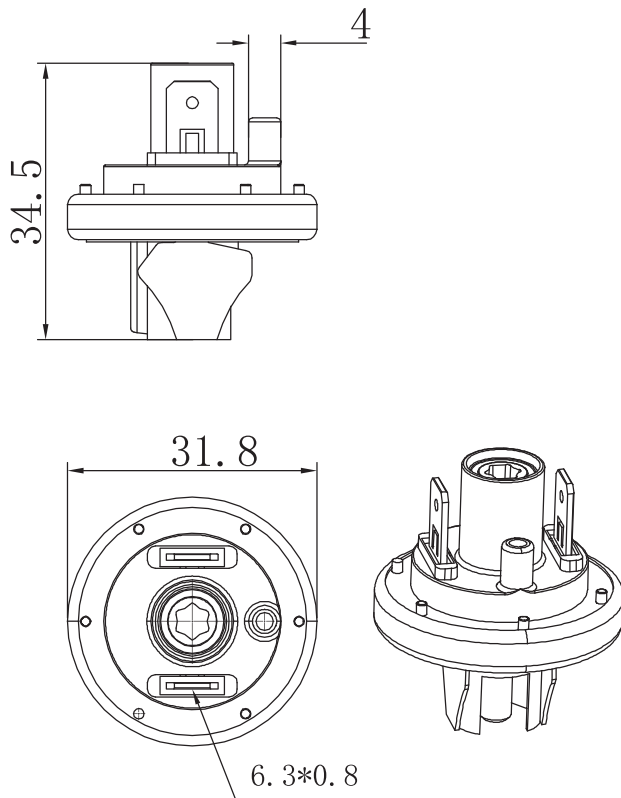

Dimension in:mm



LFS-03 can be applied to detection positive or negative pressure. It can be used as a gauge or differential pressure switch with almost no hysteresis. If 2 switch points are required, 2 pressure switches with different calibrations should be employed. The method of fixing the tab terminals to the switch body does not allow for absolute air sealing. The switch is therefore not recommended for applications where static vacuum has to be maintained. However, special models with additional pressure spring which allow for the vacuum to be connected to the pressure inlet side are available on request.

## LFS-03 Order Ref NO

LFS-03 0 0 0 W10 - V90  
**A B C D E**

- A Connection Type:**D=Pressure & Vacuum Connection ; 0=Vacuum Connection
- B Contact Carrying parts(Dimension in mm):**0=Brass Silver Plated ; G=Brass Golden Plated
- C Connection Size:**0=4mm OD tube (G1/8,NPT1/8,M10×1 Male connection are optional)
- D Wire Lead:**0=Without,Wxx=Length of wire lead in inches,i.e.W10=10inch wire lead;Terminal is available on customer's request
- E Pressure setting in mbar :**i.e. V90=90mbar vacuum, P90=90mbar positive

## Specification

Model	LFS-03
Media	Non-hazardous gas only
Electrical Function	1 pole NO or 1 pole NC
Electrical Rating	250mA ,250V(Pmax:2.5bar)
Ambient Temperature	-10°C to +90°C
Terminal	4.8mm×0.8mm copper alloy
Pressure Range	-15-800mbar
Maximum Pressure	2500mbar
Connection	Inlet 4.0mm for tube connection (Threaded inlet M10×1, NPT1/8 or G1/8 Male)

Conversion:1mbar=100Pa 1"W.C=249Pa



# LF708

## Pressure switch

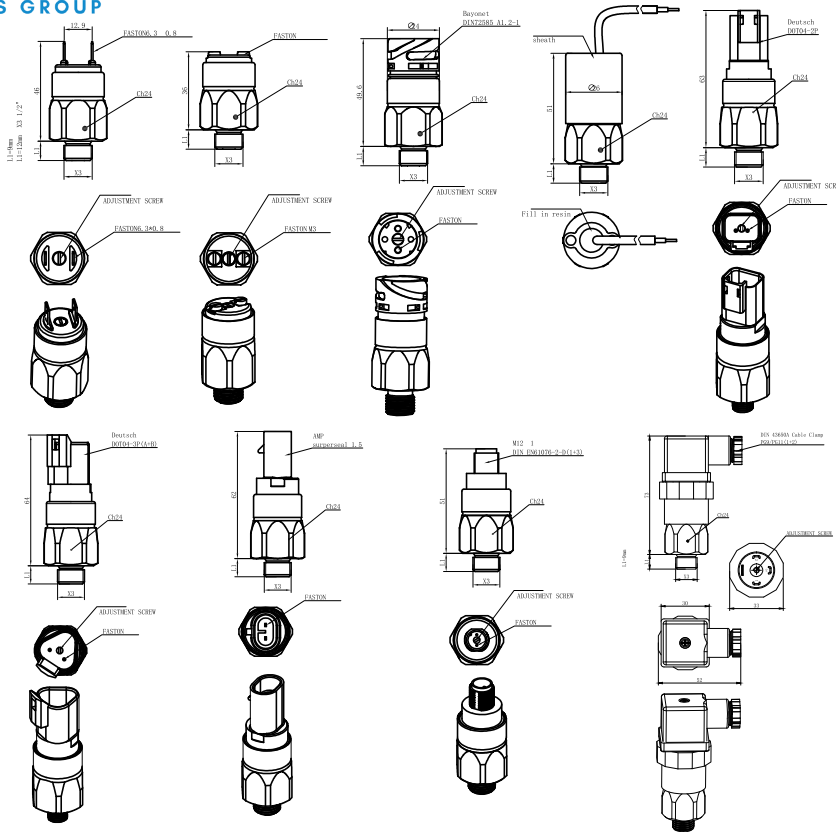

In the industrial and automotive fields, a certain pressure value is usually set for the equipment. When the pressure reaches this value, the system will send an electronic signal to start the mechanical equipment which triggers a warning (such as a leak of equipment, an alarm, etc.). This is Diapragm type pressure switch. The max pressure can not be exceeded to 300bar, SPDT

LF708 Order Ref NO Dimension in : mm

LF708-11111111-3 bar

A B C D E F G

Number	A Connection (X3)	B Body Material	C Diapragm	D Electric Terminals	E Cover	F Circuitry	G Pressure range	Tolerance	Pressure direction
1	G1/8 Male	Zinc plated steel	NBR	1/4 Blade	No	NO	0.1-1bar	±0.2bar	Increasing
2	NPT1/8 Male	Stainless steel	FKM	M3 Screws	Up	NC	1-5bar	±0.3bar	Decreasing
3	M10*1 Male	Brass	EPDM	Clip DIN72585(NO)	Side		1-10bar	±0.5bar	
4	UNF7/16 Male		HNBR	Resin wire leads			10-20bar	±1bar	
5	G1/4 Male		VMQ	DOT4-2P			20-50bar	±2bar	
6	NPT1/4 Male			DOT4-3P(A+B)					
7	G1/2 Male			AMP surperseal					
8	G1/4 Female			M12×1 DIN EN61076-2-D(1+3)					
9	M12*1.5 Female			DIN 43650A Cable Clamp(1+2)					

### Specification

General	Value
Body Material	Zinc plated steel/Stainless steel/Brass
Contact	Silver cadmium alloy/gold plated is available
Max Voltage	42V / MAX100VAC
Max Current	4A
Working Temperature Range	-40°C--+100°C(Different Diapragm)
Mechanic Life Endurance	10 <sup>6</sup> times
Electric Life Endurance	10 <sup>5</sup> times
Pollution Situation	Normal
Protection level	IP00(Terminal 1-2),IP67(Terminal 3-8),IP65(Terminal 9)
Upper cover	IP54(Termial 1-2)
Side cover	IP55(Termial 1-2)
Applicable Rule	EN 60730-1
Max Working Pressure	Zinc plated steel/Stainless steel: 160bar Brass:40bar
Burst Pressure	Zinc plated steel/Stainless steel: 300bar Brass: 80bar
Weight	~85gr

Conversion:1kgf/cm=14.2psi 1bar=14.5psi

# LF708A

## Pressure switch

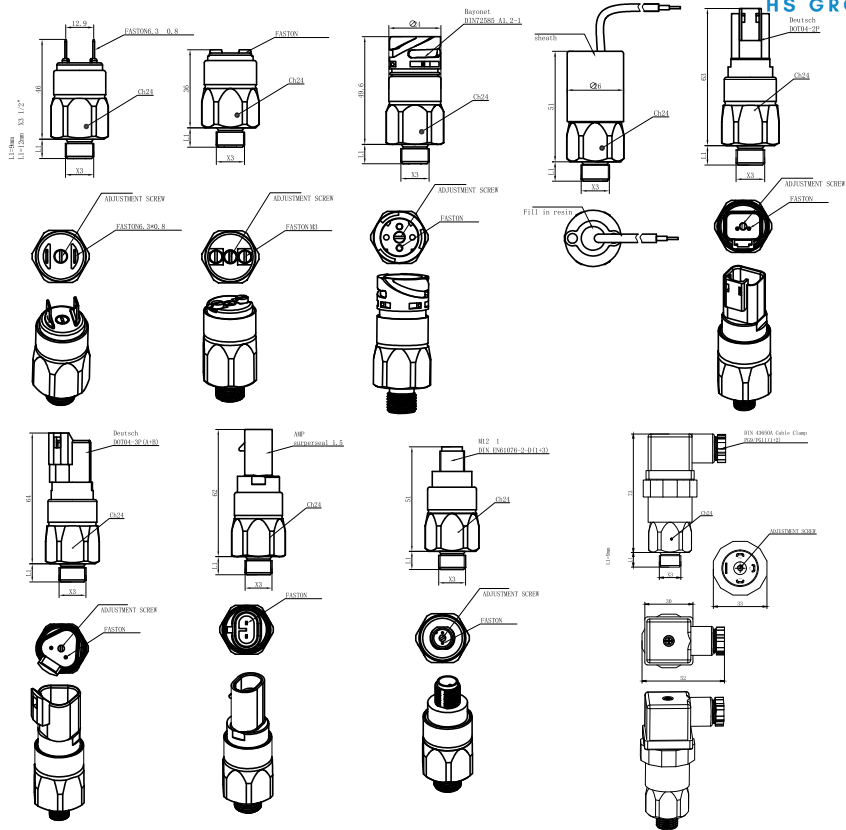

In the industrial and automotive fields , a certain pressure value is usually set for the equipment .When the pressure reaches this value, the system will send an electronic signal to start the mechanical equipment, Which triggers a warning (such as a leak of equipment, an alarm, etc.). This is Diaphragm type pressure switch. The max pressure can not be exceeded to 600bar.

**LF708A Order Ref NO** Dimension in : mm

**LF708A- 1 1 1 1 1 1 1 1-3bar**

**A B C D E F G**

Number	A Connection (X3)	B Body Material	C Diaphragm	D Electric Terminals	E Cover	F Circuitry	G Pressure range	Tolerance	Pressure direction
1	G1/4 Male	Zinc plated steel	NBR	1/4 Blade	No	NO	2.5-6bar	±0.3bar	Increasing
2	NPT1/8 Male	Stainless steel	FKM	M3 Screws	Up	NC	3-10bar	±0.5bar	Decreasing
3	M10*1 Male		EPDM	Clip DIN72585(NO)	Side		5-20bar	±1bar	
4	UNF7/16 Male			Resin wire leads			15-50bar	±2bar	
5				DOT4-2P					
6				DOT4-3P(A+B)					
7				AMP surperseal					
8				M12×1 DIN EN61076-2-D(1+3)					
9				DIN 43650A Cable Clamp(1+2)					

### Specification

General	Value
Body Material	Zinc plated steel/Stainless steel
Contact	Silver cadmium alloy,gold plated is available
Max Voltage	42V/ MAX100VAC
Max Current	4A
Working Temperature Range	-40°C---+100°C(Different Diaphragm)
Mechanic Life Endurance	10 <sup>6</sup> times
Electric Life Endurance	10 <sup>5</sup> times
Pollution Situation	Normal
Protection level	IP00(Terminal 1-2),IP67(Terminal 3-8),IP65(Terminal 9)
Upper cover	IP54(Termial1-2)
Side cover	IP55(Termial1-2)
Applicable Rule	EN 60730-1
Max Working Pressure	450bar
Burst Pressure	600bar
Weight	~85gr

Conversion:1kgf/cm=14.2psi 1bar=14.5psi

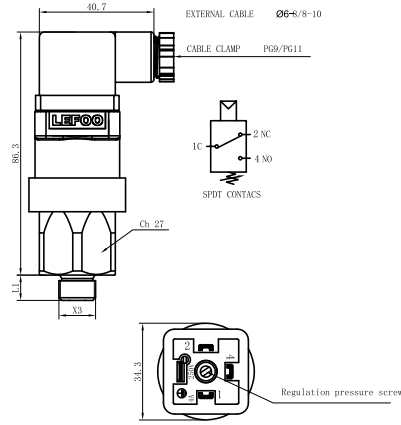
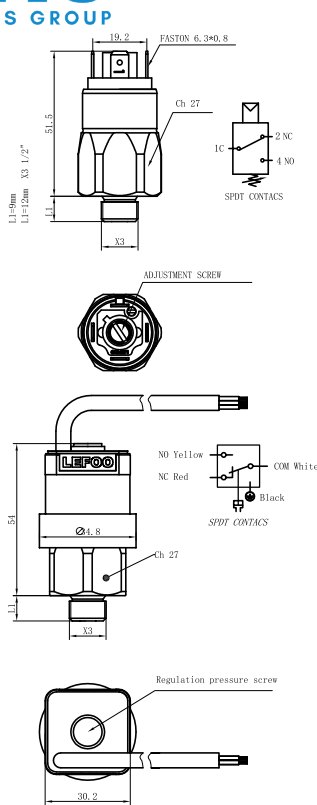

Dimension in : mm

# LF727

## Pressure switch



In the industrial and automotive fields , a certain pressure value is usually set for the equipment . When the pressure reaches this value, the system will send an electronic signal to start the mechanical equipment Which triggers a warning (such as a leak of equipment , an alarm , etc .) . This is Diaphragm type pressure switch . The max pressure can not be exceeded to 300bar,SPDT

### LF727 Order Ref NO

LF727-111111-3bar  
**A B C D E F**

Number	A Connection (X3)	B Body Material	C Diaphragm	D Electric Terminals	E Pressure range	Tolerance	F Pressure direction
1	G1/8 Male	Zinc plated steel	NBR	Blade	0.3-1.5bar	±0.2bar	Increasing
2	NPT1/8 Male	Stainless steel	FKM	Hirschmann Pg9	1-5bar	±0.3bar	Decreasing
3	M10*1 Male	Brass	EPDM	Hirschmann Pg11	1-10bar	±0.5bar	
4	UNF7/16 Male		HNBR	Resin wire-leads	5-20bar	±1bar	
5	G1/4 Male		VMQ		15-50bar	±2bar	
6	NPT1/4 Male						
7	G1/2 Male						
8	G1/4 Female						
9	M12*1.5 Female						

### Specification

General	Value
Body Material	Zinc plated steel/Stainless steel/Brass
Contact	Silver cadmium alloy
Max Voltage	250VAC/42VDC
Max Current	4A
Working Temperature Range	-40°C -- +100°C (Different Diaphragm)
Mechanic Life Endurance	10 <sup>6</sup> times
Electric Life Endurance	10 <sup>5</sup> times
Pollution Situation	Normal
Repeated Accuracy	2%
IP Grade	Wire leads Ip00, Hirschmann IP65, Resined wires IP67
Applicable Rule	EN 60730-1
Max Working Pressure	Zinc plated steel/Stainless steel: 150bar Brass: 40bar
Burst Pressure	Zinc plated steel/Stainless steel: 300bar Brass: 80bar
Weight	~140g

Conversion: 1kgf/cm=14.2psi 1bar=14.5psi

# LF727A

## Pressure switch

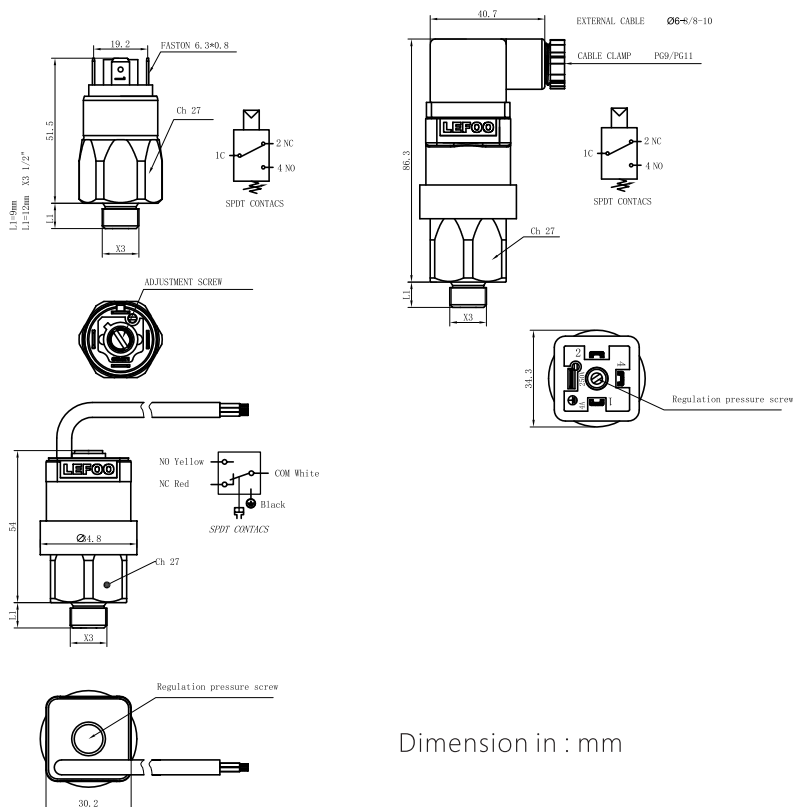

Dimension in : mm

In the industrial and automotive fields, a certain pressure value is usually set for the equipment. When the pressure reaches this value, the system will send an electronic signal to start the mechanical equipment. Which triggers a warning (such as a leak of equipment, an alarm, etc.). This is Diaphragm type pressure switch. The max pressure can not be exceeded to 600bar,SPDT

### LF727A Order Ref NO

LF727A-111111-3bar

A B C D E F

Number	A Connection (X3)	B Body Material	C Diaphragm	D Electric Terminals	E Pressure range	Tolerance	F Pressure direction
1	G1/4 Male	Zinc plated steel	NBR	Blade	3-6bar	±0.3bar	Increasing
2	NPT1/8 Male	Stainless steel	FKM	Hirschmann Pg9	3-10bar	±0.5bar	Decreasing
3	M10*1 Male		EPDM	Hirschmann Pg11	5-20bar	±1bar	
4	UNF7/16 Male			Resin wire-leads	15-50bar	±2bar	

### Specification

General	Value
Body Material	Zinc plated steel/Stainless steel/Brass
Contact	Silver cadmium alloy
Max Voltage	250VAC/42VDC
Max Current	4A
Working Temperature Range	-40°C--+100°C(Different Diaphragm)
Mechanic Life Endurance	10 <sup>6</sup> times
Electric Life Endurance	10 <sup>5</sup> times
Pollution Situation	Normal
Repeated Accuracy	2%
IP Grade	Wire leads Ip00,Hirschmann IP65,Resined wires IP67
Applicable Rule	EN 60730-1
Max Working Pressure	450bar
Burst Pressure	600bar
Weight	~140g

Conversion:1kgf /cm=14.2psi 1bar=14.5psi

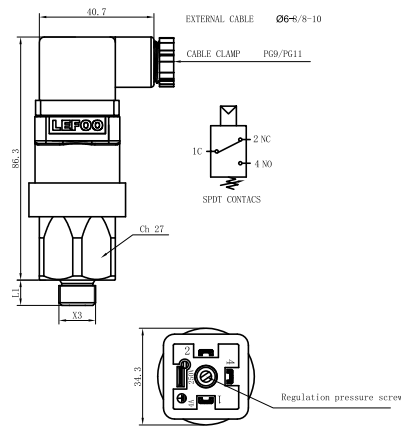
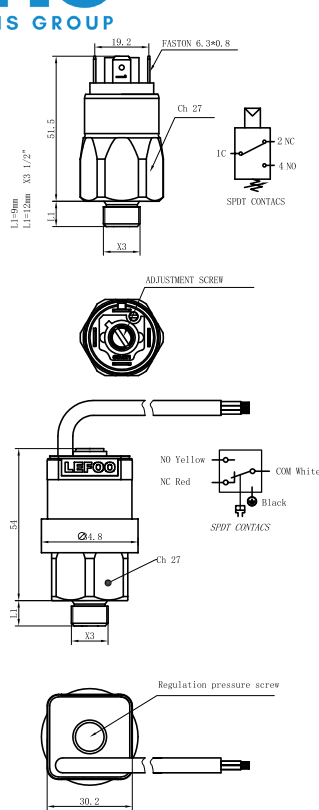

Dimension in : mm

# LF727B

Pressure switch



In the industrial and automotive fields , a certain pressure value is usually set for the equipment When the pressure reaches this value, the system will send an electronic signal to start the mechanical equipment Which triggers a warning (such as a leak of equipment , an alarm , etc.) . This is the plunger type pressure switch. The max pressure can not be exceeded to 600bar,SPDT

## LF727B Order Ref NO

LF727B- 1 1 1 1 1 1 -50bar

A B C D E F

Number	A Connection (X3)	B Body Material	C Diaphragm	D Electric Terminals	E Pressure range	Tolerance	F Pressure direction
1	G1/8 Male	Zinc plated steel	NBR	Blade	30-100bar	±5bar	Increasing
2	NPT1/8 Male	Stainless steel	FKM	Hirschmann PG9	50-150bar	±10bar	Decreasing
3	M10*1 Male		EPDM	Hirschmann PG11	100-200bar	±15bar	
4	UNF7/16 Male		HNBR	Resin wire-leads			
5	G1/4 Male		VMQ				
6	NPT1/4 Male						
7	G1/2 Male						
8	G1/4 Female						
9	M12*1.5 Female						

## Specification

General	Value
Body Material	Zinc plated steel/Stainless steel/Brass
Contact	Silver cadmium alloy
Max Voltage	250VAC/42VDC
Max Current	4A
Working Temperature Range	-40°C-- +100°C(Different Diaphragm)
Mechanic Life Endurance	10 <sup>5</sup> times
Electric Life Endurance	10 <sup>4</sup> times
Pollution Situation	Normal
Repeated Accuracy	2%
IP Grade	Wire leads Ip00,Hirschmann IP65,Resined wires IP67
Applicable Rule	EN 60730-1
Max Working Pressure	450bar
Burst Pressure	600bar
Weight	~140g

Conversion:1kgf /cm=14.2psi 1bar=14.5psi

# LFB

## Differential pressure gauge

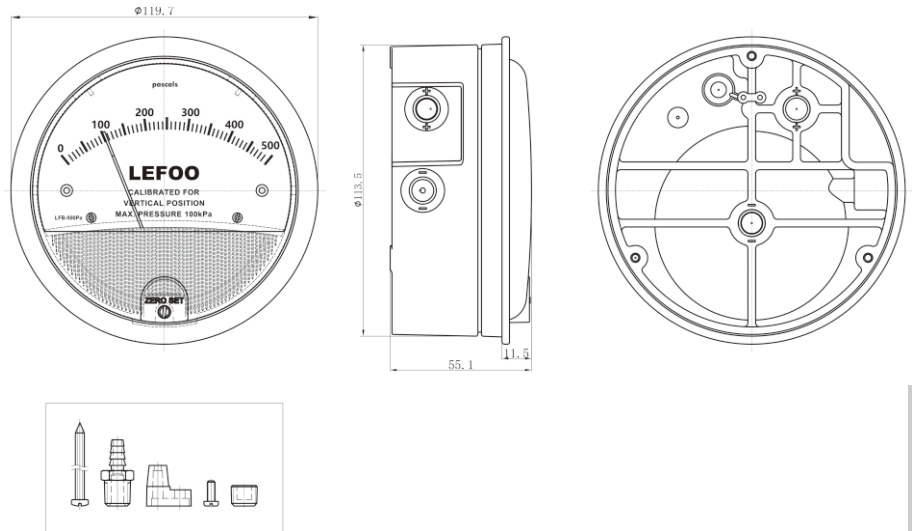

Dimension in :mm

LFB series is widely used for measuring the fans or blowers pressure, filter resistant, wind speed, furnace gas pressure, Orifice pressure difference, bubble level and hydraulic system pressure. It is also applied to regulate the air-gas combustion ratio and automatic valve or detecting the breathing, and blood pressure in medical equipment. There are some more applications like micro-electronics, aviation and space, environmental protection project, biological engineering, intelligent building, HVAC, food and beverage and precision electronic processing

### Specification :

- Magnetic link drive mechanism eliminates friction caused by gear drive fundamentally
- No necessity to fill with liquid
- Motion of the pointer without inertia or drift
- No hysteresis
- Excellent anti-vibration and anti-shaking performance
- Positive, negative or differential pressure can be measured
- multiple ranges are optional, minimum 0 ~ 30Pa to maximum 0 ~ 10kPa
- 2 sets of pressure ports (side, back) + 3 mounting modes = free and flexible application
- Excellent accuracy, reasonable price.

### Technical

Model	LFB
Measuring range	0-30Pa, -30-30Pa, 0-60Pa, -60-60Pa, 0-125Pa, -125-125Pa, 0-250Pa, -250-250Pa, 0-300Pa, 0-500Pa, 0-750Pa, 0-1kPa, 0-2kPa, 0-3kPa, 0-4kPa, 0-5kPa, 0-6kPa, 0-7kPa, 0-8kPa, 0-9kPa, 0-10kPa
Accuracy	± 2% FS under 21 °C (>60 pa,3% ; <60pa,4%)
Over load	around 110kPa~150kPa, the rubber plug for overpressure will be flush away
Environment temperature	-7°C~ 60°C
IP Grade	Ip67

# LFZ

## Standard Rotary Actuator

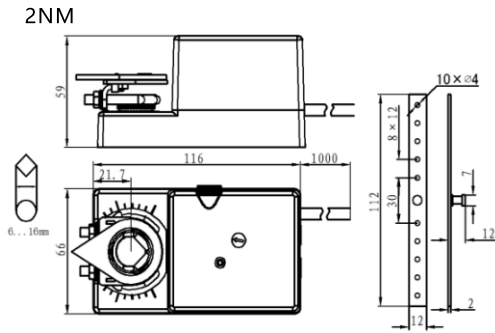

Dimension drawing: 4-6NM

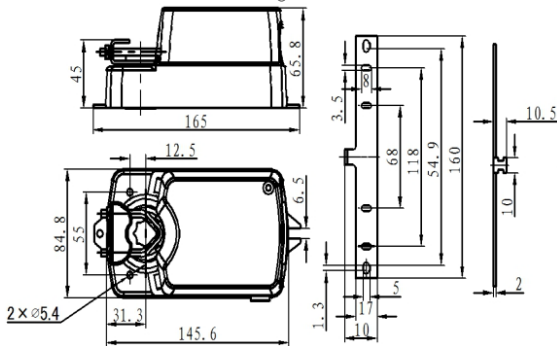

Dimension drawing: 8-40NM

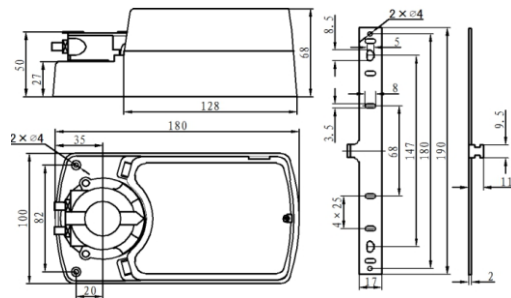

Dimension in : mm



LFZSeries electric damper actuator adopts imported DC motor/brushless motor to supply power energy, And it can offer 2NM~40NM torque, it can directly works on rotary control of air system and water systems,and can realize signal control of voltage 0(2)-10V and current 0(4)-20mA also can provide mutual convertible current or voltage signal feedback ,It is easy to install and can be easily fixed on the square shaft, round shaft or other shaped damper shaft,This product has advantage of long life, low noise, and multi-functional intelligent control.The whole series of products are available with manual operation function. The protection grade of the product is IP54, and it's stable and efficient, with full overload protection function. All products are equipped with manual limit.

Model	Output Torque	Power Supply	Running Time	Control Signal	Optional F auxiliary switch
LFZ0224/230-K/KF	2N	24V/230V	20-25S	ON-OFF control	one set of auxiliary switches
LFZ0224/230-M/MF	2N	24V/230V	20-25S	0(2)~10V/0(4)~20mA	one set of auxiliary switches
LFZ0424/230-K/KF	4N	24V/230V	25-30S	ON-OFF control	one set of auxiliary switches
LFZ0424/230-M/MF	4N	24V/230V	25-30S	0(2)~10V/0(4)~20mA	one set of auxiliary switches
LFZ0624/230-K/KF	6N	24V/230V	25-30S	ON-OFF control	one set of auxiliary switches
LFZ0624/230-M/MF	6N	24V/230V	25-30S	0(2)~10V/0(4)~20mA	one set of auxiliary switches
LFZ0824/230-K/KF	8N	24V/230V	30-45S	ON-OFF control	one set of auxiliary switches
LFZ0824/230-M/MF	8N	24V/230V	30-45S	0(2)~10V/0(4)~20mA	one set of auxiliary switches
LFZ1624/230-K/KF	16N	24V/230V	30-45S	ON-OFF control	one set of auxiliary switches
LFZ1624/230-M/MF	16N	24V/230V	30-45S	0(2)~10V/0(4)~20mA	one set of auxiliary switches
LFZ2424/230-K/KF	24N	24V/230V	120-160S	ON-OFF control	one set of auxiliary switches
LFZ2424/230-M/MF	24N	24V/230V	120-160S	0(2)~10V/0(4)~20mA	one set of auxiliary switches
LFZ3224/230-K/KF	32N	24V/230V	160-200S	ON-OFF control	one set of auxiliary switches
LFZ3224/230-M/MF	32N	24V/230V	160-200S	0(2)~10V/0(4)~20mA	one set of auxiliary switches
LFZ4024/230-K/KF	40N	24V/230V	200-220S	ON-OFF control	one set of auxiliary switches
LFZ4024/230-M/MF	40N	24V/230V	200-220S	0(2)~10V/0(4)~20mA	one set of auxiliary switches

Ordering information - KF/MF is series with auxiliary switch, please provide complete model information when ordering.

## Specification

General	Value							
Electrical parameters	Rated voltage	AC24V 50/60Hz DC24V /AC100...240V 50/60Hz						
	Rated voltage range	AC/DC19.2...28.8V /AC85...265V						
	Power consumption	Operating state 4.5w, Standby state 0.5W						
	Wire specification	0.5mm <sup>2</sup>						
	Terminal specification	Max2mm <sup>2</sup>						
Function parameter	torque	2Nm	4Nm	6Nm	8Nm	16Nm	32Nm	48Nm
	suitable air door size	0.3m <sup>2</sup>	0.5m <sup>2</sup>	0.8m <sup>2</sup>	1.2m <sup>2</sup>	2.5m <sup>2</sup>	3.7m <sup>2</sup>	5.2m <sup>2</sup>
	Rotation direction	Can be selected by DIP switch						
	manual adjustment	Actuator can be manually adjusted after pressing the gear set disengagement button						
	Nominal/Maximum Corner	90°/95°						
	noise level	46dBA (within 1 meter)						
	location indication	Rotation angle provided by position indicator						
Work Environment	Electrical grade	III (safety low voltage)			II (double insulation)			
	Protection Grade	IP54						
	working environment temperature	-20°C~+50°C						
	Storage ambient temperature	-20°C~+50°C						
	Temperature test	95% RH, non-condensing /EN 60730-1						
Dimension Drawing	L×W×H/mm	detail see dimensional drawing						
	Minimum shaft length	>50mm						
	Weight	<1.3 Kg						

## Wiring mode

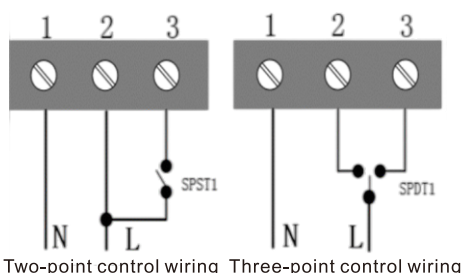

Switch output connection method, working  
Voltage: AC/DC 24V; AC100V...AC240V

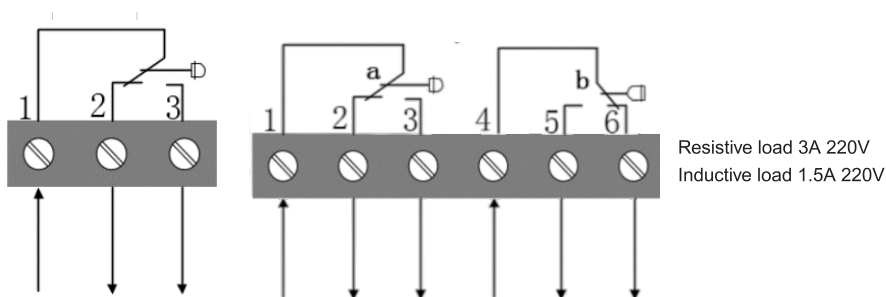

One set of auxiliary switch wiring methods Two sets of auxiliary switch wiring methods

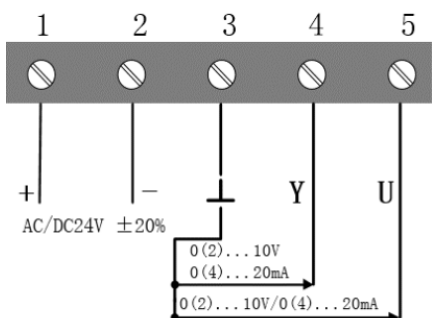

Volt0(0)...10V input resistance ≥ 200KΩ  
Current0(4) ... 20mA input resistance = 500Ω  
Analog wiring, the power supply  
Voltage can be AC/DC 24V

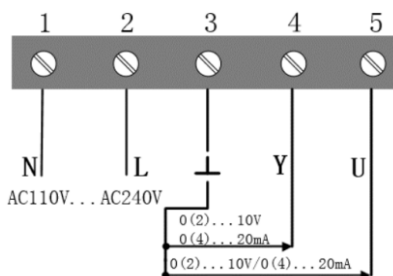

Volt0(0)...10V input resistance ≥ 200KΩ  
Current0(4) ... 20mA input resistance = 500Ω  
Analog wiring, supply voltage  
AC100V...AC240V

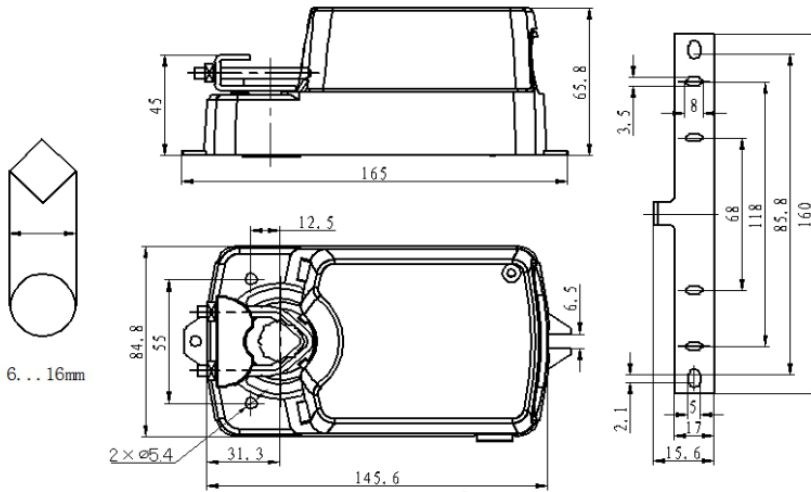

Dimension drawing: 8-40NM

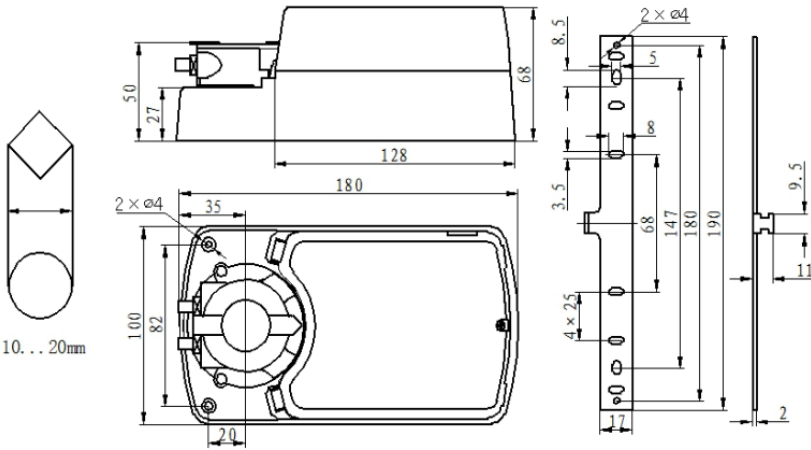

# LFZ-Q

## Fast Running Rotary Actuators



LFZ-Q05/08/16/24/40 Series Electric Damper Actuators adopt imported DC motor/brushless motor to provide power, with torques of 5NM, 8NM, 16NM, 24NM, 40NM for choosing. The series are widely used in rail transit, ventilation system, laboratory and other fields which need fast control. They are easy to install and fix on square shaft, circular shaft or other shapes of damper connecting shafts. They have long service life, low noise and can achieve multi-function intelligent control. The whole series are with manual operation function and manual limit, IP54 protection grade, full overload protection function to ensure safe use.

### Specification

Dimension in : mm

Model	Output Torque	Power Supply	Run Time	Control Signal	F Auxiliary Switch
LFZ-Q0524/230-K/KF	5N	24V/230V	3.5S	On-off Control	Two sets of auxiliary switches
LFZ-Q0524/230-M/MF	5N	24V/230V	3.5S	0(2)~10V/0(4)~20mA	Two sets of auxiliary switches
LFZ-Q0824/230-K/KF	8N	24V/230V	8S	On-off Control	Two sets of auxiliary switches
LFZ-Q0824/230-M/MF	8N	24V/230V	8S	0(2)~10V/0(4)~20mA	Two sets of auxiliary switches
LFZ-Q1624/230-K/KF	16N	24V/230V	16S	On-off Control	Two sets of auxiliary switches
LFZ-Q1624/230-M/MF	16N	24V/230V	16S	0(2)~10V/0(4)~20mA	Two sets of auxiliary switches
LFZ-Q2424/230-K/KF	24N	24V/230V	<30S	On-off Control	Two sets of auxiliary switches
LFZ-Q2424/230-M/MF	24N	24V/230V	<30S	0(2)~10V/0(4)~20mA	Two sets of auxiliary switches
LFZ-Q4024/230-K/KF	40N	24V/230V	<30S	On-off Control	Two sets of auxiliary switches
LFZ-Q4024/230-M/MF	40N	24V/230V	<30S	0(2)~10V/0(4)~20mA	Two sets of auxiliary switches

Ordering information - KF/MF is series with auxiliary switch, please provide complete

## Specification

General	Value					
Electrical parameters	Rated Voltage	AC24V 50/60Hz DC24V /AC100...240V 50/60Hz				
	Rated Voltage Range	AC/DC 19.2...28.8V/AC85V...AC265V				
	Power Consumption	Running Status4.5W,Standby Status 0.5W				
	Cable Size	0.5mm <sup>2</sup>				
	Terminal Size	Max2mm <sup>2</sup>				
Function parameter	Torque	5Nm	8Nm	16Nm	40Nm	48Nm
	Suitable damper Size	0.5m <sup>2</sup>	1.2m <sup>2</sup>	2.5m <sup>2</sup>	1.2m <sup>2</sup>	4.2m <sup>2</sup>
	Rotation direction	Can be selected by DIP switch				
	manual adjustment	Actuator can be manually adjusted after pressing the gear set disengagement button				
	Nominal/Maximum Corner	90°/95°				
	noise level	46dBA (within 1 meter)				
	location indication	Rotation angle provided by position indicator				
Work Environment	Electrical Grade	III (SELV)II (Double Insulation)				
	Degree of Protection	Ip54				
	Working Temperature	-20°C~+50°C				
	Storage Temperature	-30°C~+80°C				
	Temperature Test	95%RH,No Condensation/EN 60730-1				
Dimension Drawing	L×W×H/mm	see dimensional details				
	Minimum shaft length	>50mm				
	Weight	<1.3 Kg				

## Wiring mode

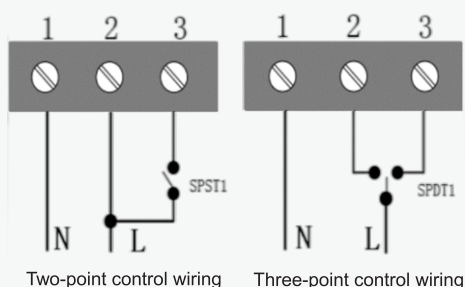

Switch output connection method,  
Working voltage: AC/DC 24V; AC100V...AC240V

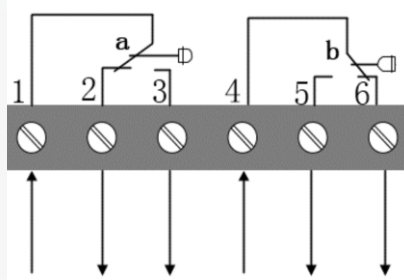

Resistive load 3A 220V  
Inductive load 1.5A 220V

Two sets of auxiliary switch wiring methods

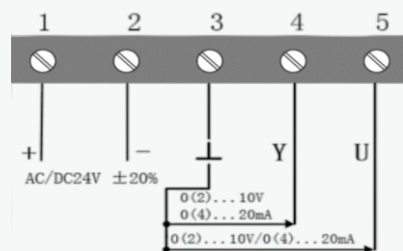

Volt0(0)...10V input resistance≥200KΩ  
Current0(4)...20mA input resistance=500Ω

Analog wiring, the power supply  
Voltage can be AC/DC 24V

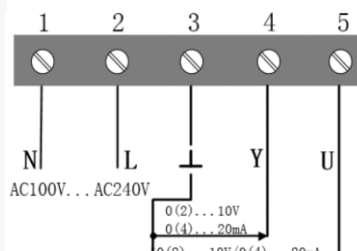

Volt0(0)...10V input resistance≥200KΩ  
Uurrent0(4)...20mA input resistance=500Ω

Analog wiring, supply voltage  
AC100V...AC240V

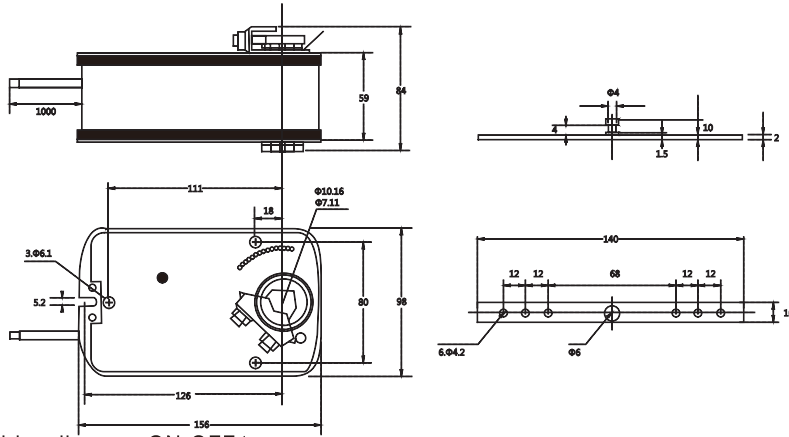

Wiring diagram: ON-OFF type

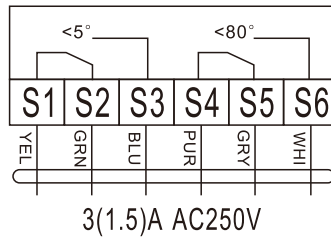
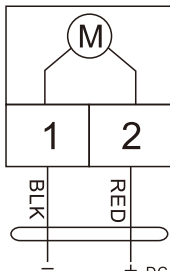

**Specification**

DC 24V  
AC 24V  
AC 230V

Model	Output Torque	Power Supply	Run Time	Control Signal	F Auxiliary Switch
LFZ-T0524-K	5N	24V	Motor run time 70S; Spring reset time <math>< 20s</math>	ON-OFF control	/
LFZ-T0524-KF	5N	24V	Motor run time 70S; Spring reset time <math>< 20s</math>	ON-OFF control	Two sets of auxiliary switches
LFZ-T05230-K	5N	230V	Motor run time 70S; Spring reset time <math>< 20s</math>	ON-OFF control	/
LFZ-T05230-KF	5N	230V	Motor run time 70S; Spring reset time <math>< 20s</math>	ON-OFF control	Two sets of auxiliary switches

**Specification**

General	Value	
Electric Parameter	Rated Voltage	AC24V 50/60Hz DC24V /AC100...240V 50/60Hz
	Rated Voltage Range	AC/DC19.2...28.8V /AC85...265V
	Power Consumption	Run Status Standby Status
	Cable size	0.5mm <sup>2</sup>
	Auxiliary switch rating	3A,AC230V
Function parameter	Torque	5NM
	Suitable damper size	Under normal wind resistance, 1NM matches 0.1 square meter (Include airtight valve matching scheme)
	Rotating Direction	Manual Adjustment Available
	Manual Operation	Available in all series
	Rotation Angle	Max 95°. Full stroke can be adjusted by mechanical limit
	Run Time	adjustable within the parameter range
	Noise Level	Motor running 46db, spring reset 62db
	Position indication	mechanical indication
Work Environment	Electrical Grade	III(Safelow voltage)II(Double Insulation)
	Degree of Protection	IP54
	Working Temperature	-20..+50°C/IEC 721-3-3
	Storage Temperature	-30..+80°C/IEC 721-3v-2
	Temperature Test	95%RH, No Condensation/EN 60730-1
Dimension drawing	Dimension	See Dimension drawing
	Length of Shaft	>50mm
	Size of Shaft	10-20Round Shaft 10x10.16x16Round Shaft
	Weight	<math>< 1.8kg</math>

# LFZ-T

## Spring Reset Damper Actuator



LFZ-T05 Series Electric Damper Actuators adopt imported DC motor/brushless motor to provide power with torques of 5NM. It is widely used in building ventilation fields, which can realize mechanical reset when power off and electric start, providing more than 30000 times of repeated action

# LFZ-DQ

## Electrical regulating ball valve

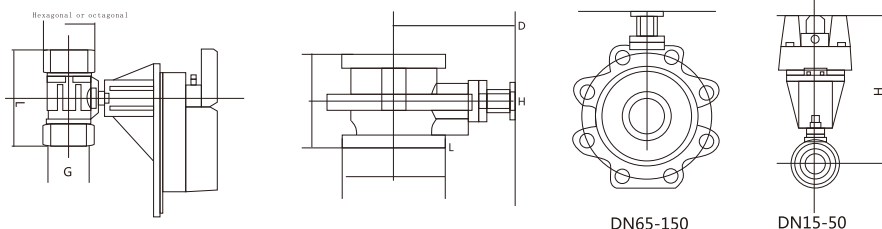

In HVAC and water system, ball valves are used as automatic control valves. It has adjustable flow ratio, high reliability and long service life. It uses graphite to strengthen the valve body sealing ring and double EPDM valve stem sealing ring. It has integrated valve distribution butterfly inside and is not afraid of reverse pressure difference. It has the characteristic of equal percentage flow. Its high turn-off pressure is 1.4MPa. The rated working pressure is PN20. The maximum working pressure difference is 0.35Mpa. It has a manual actuator short-circuit push button. Working temperature is -5 to 121 °C. It is suitable for central air conditioning, hot and cold water supply system, steam humidification, etc.

### Dimensional Drawing

Model	G	H(mm)	H1(mm)	L(mm)	Model	Flange indexing circle	L(mm)	D(mm)	H(mm)	n-d
DN 15	G1/2	184	37.5	60	DN 65	145	97	105	136	4-18
DN 20	G3/4	184	44	73	DN 80	160	108	120	140	8-18
DN 25	G1	189	47	89	DN 100	175	120	145	104	8-18
DN 32	G1-1/4	199	52.5	102.5	DN 125	200	145	175	115	8-18
DN 40	G2-1/2	208	57	113	DN 50	230	165	205	138	8-18
DN 50	G2	219	62	127.5						

### Specification

Model	Diameter	two-way flow	three-way branch flow	power supply	control signal	F auxiliary switch	Bracket	Actuator
LFZ-DQ 15	DN 15	4.0	2.5	AC/DC24V/230V	switch/adjust	one set	High platform ball valve bracket with packing / short ball valve bracket with packing	Actuator with 4NM
LFZ-DQ 20	DN 20	4.0	2.5	AC/DC24V/230V	switch/adjust	one set	High platform ball valve bracket with packing / short ball valve bracket with packing	Actuator with 4NM
LFZ-DQ 25	DN 25	10.0	6.3	AC/DC24V/230V	switch/adjust	two sets	High platform ball valve bracket with packing / short ball valve bracket with packing	Actuator with 6NM
LFZ-DQ 32	DN 32	16.0	10.0	AC/DC24V/230V	switch/adjust	two sets	High platform ball valve bracket with packing / short ball valve bracket with packing	Actuator with 6NM
LFZ-DQ 40	DN 40	25.0	16.0	AC/DC24V/230V	switch/adjust	two sets	High platform ball valve bracket with packing / short ball valve bracket with packing	Actuator with 6NM
LFZ-DQ 50	DN 50	40.0	25.0	AC/DC24V/230V	switch/adjust	two sets	High platform ball valve bracket with packing / short ball valve bracket with packing	Actuator with 6NM
LFZ-DQ 65	DN 65	63.0	/	AC/DC24V/230V	switch/adjust	two sets	High platform ball valve bracket with packing	Actuator with 16NM
LFZ-DQ 80	DN 80	100.0	/	AC/DC24V/230V	switch/adjust	two sets	High platform ball valve bracket with packing	Actuator with 16NM
LFZ-DQ 100	DN 100	160.0	/	AC/DC24V/230V	switch/adjust	two sets	Ball valve bracket with packaging	Actuator with 24NM
LFZ-DQ 125	DN 125	250.0	/	AC/DC24V/230V	switch/adjust	two sets	Ball valve bracket with packaging	Actuator with 24NM
LFZ-DQ150	DN 150	400.0	/	AC/DC24V/230V	switch/adjust	two sets	Ball valve bracket with packaging	Actuator with 32NM

### Technical Parameter

General	Value	General	Value
Diameter range	DN15-DN150	Rotation angle	0-90°
Connection mode	DN15-DN50(female thread connection) DN65-DN150(flanged connection)	Installation position	vertical installation
Medium	Hot and cold water, unsaturated steam, 50% ethanol water, etc.	Flow characteristics	Equal percentage
Medium temperature range	-5°C-120°C	Bearing pressure of valve body	1.6Mpaflang2.0Mpa screw thread
Adjustable ratio of valve	>100	Material of valve body	Forged brass (thread) nodular cast iron (flange)
Leakage rat	no leakage from the factory	Valve core material	304 stainless steel
Max. allowable pressure difference	0.35Mpa	Valve stem material	304 stainless steel
Max. cut off pressure difference	1.4Mpa	Sealing ring	EPDM

# LFSV-D

Solenoid Valve

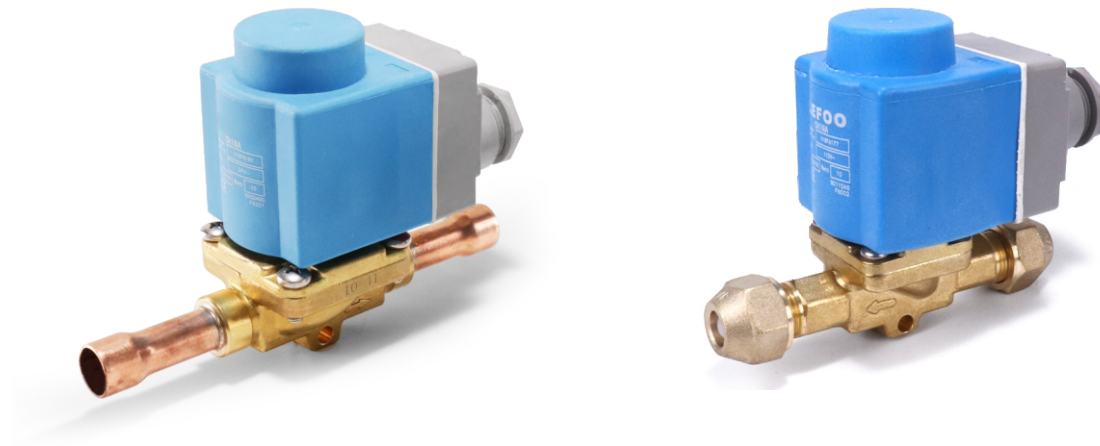

## Product Description

• LFSV-D series solenoid valves are divided into direct and servo-operated, and are mainly used for on-off control of refrigerants in refrigeration systems, air conditioners and heat pumps.

## Features

- The joints of the valve body have good sealing performance. The valve body and the coil can be supplied as a whole or separately. The valve body is universal
- Various coil voltages are available, the coil power consumption is low, the reliability is high, the overall sealing design is adopted, and the protection level reaches Ip65
- The maximum working pressure difference of the solenoid valve is large, it can work stably under the condition of voltage fluctuation, and has a long service life
- The solenoid valve is a detachable structure, which is extremely convenient for installation and maintenance

## Technical Parameters

Model	LFSV-D
Refrigerants	R22,R134a,R407C,R404A,R410A,R507C and other refrigerants
Medium temperature	-30°C~+105°C
Environment temperature and humidity	-40°C~+65°C, ≤95%RH
Coil standard voltage	AC220V, AC110V, DC24V, DC12V (contact LEFOO for other customized voltages)
Allowable Voltage Fluctuation for Solenoid	+10%~ -15%
Wiring	Standard DIN junction box or direct lead
Installation position	Suction- exhaust port and liquid pipe port

## Valve body Technical data

Model	Connection	Pipe size (inch)	Kv (m <sup>3</sup> /h)	Max.working pressure (MPa)	Dimension (mm)						
					ΦD	M (UNF)	L1	L	A	H	
LFSV-D-2	SAE	1/4	0.2	4.5	-	7/16-20	-	58	91	65	
	ODF				6.5	-	7	90	91	65	
LFSV-D-3	SAE	3/8	0.27		-	5/8-18	-	64	91	65	
	ODF				10.1	-	8	104	91	65	
LFSV-D-3	SAE		0.8		-	5/8-18	-	87	91	72	
	ODF				10.1	-	8	108	91	72	
LFSV-D-4	SAE	1/2			-	3/4-16	-	89	91	72	
	ODF				12.8	-	10	114	91	72	
LFSV-D-5	SAE	5/8	2.6		-	7/8-14	-	104	91	75	
	ODF				16.1	-	14	152	91	75	
LFSV-D-6	SAE	3/4			-	1-1/16-14	-	104	91	75	
	ODF				19.2	-	16	158	91	75	
LFSV-D-7	ODF	7/8			5.7	22.3	-	17	180	91	88

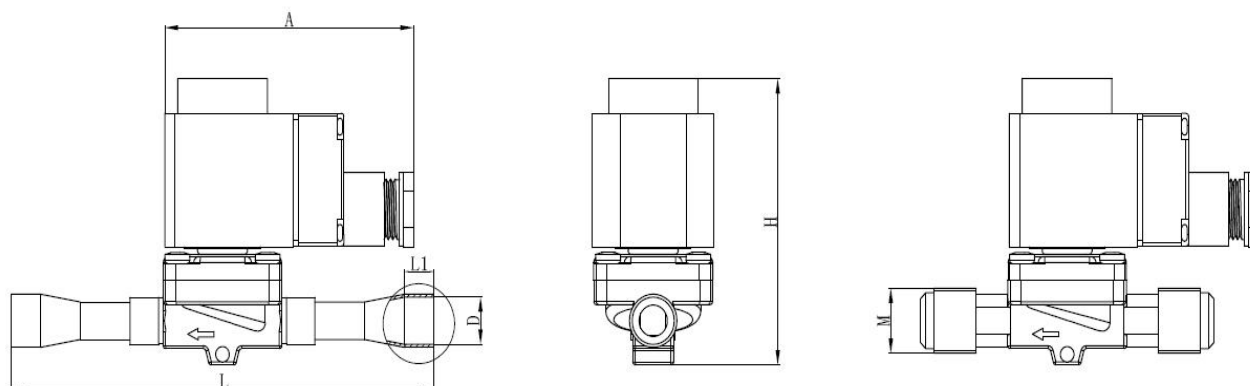

## Coils Technical Data

Model	Voltage (V)	Fregency (HZ)	Power consumption (W)	insulation grade	Voltage fluctuation	Protection Grade	Coil type
D-XQ01	DC24	-	10/9W	F	+10%~-15%	IP65	DIN junction box
D-XQ02	AC110	50/60					
D-XQ03	AC220						
D-XQ04	DC24	-					Direct lead (standard 1 meter length)
D-XQ05	AC110	50/60					
D-XQ06	AC220						

## Coil dimension:

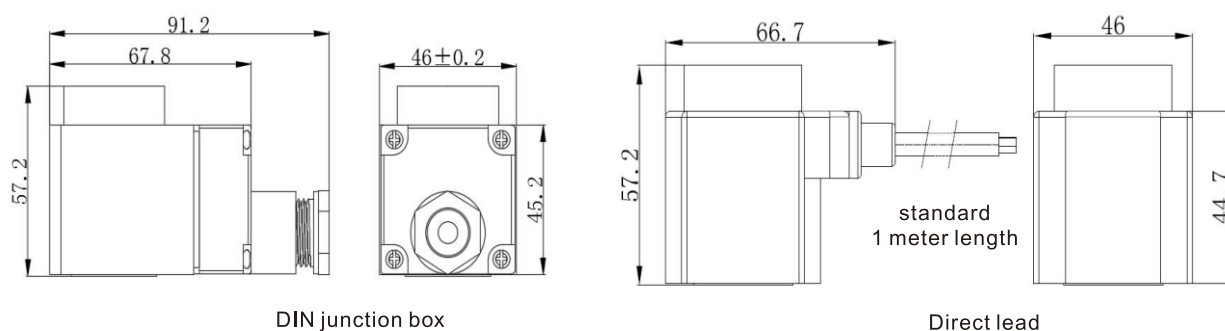

# LFSV-K

Solenoid Valve

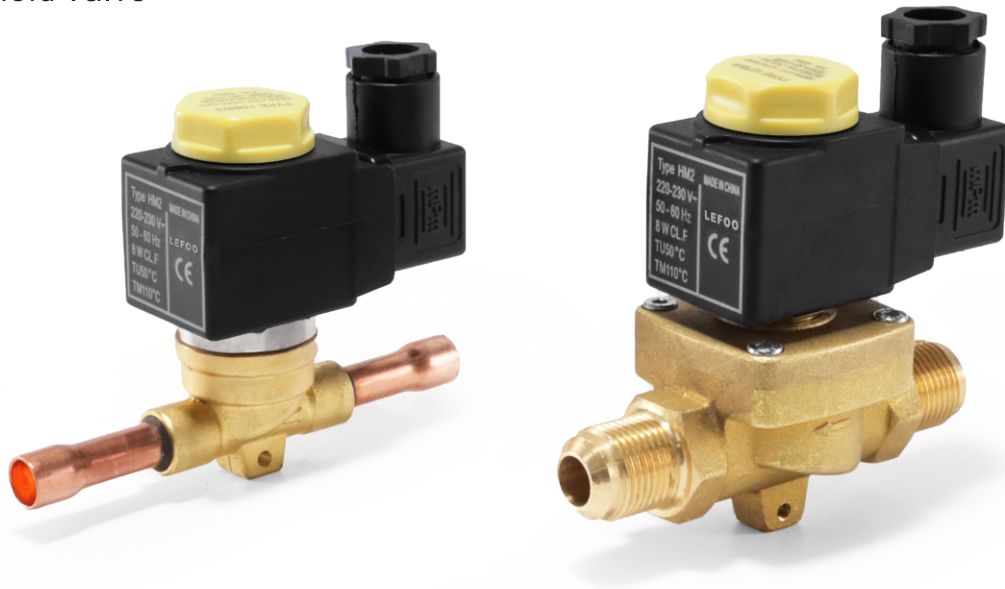

## Product Description

LFSV-Kseries solenoid valves are divided into direct and servo-operated, and are mainly used for on-off control of refrigerants in refrigeration systems, air conditioners and heat pumps.

## Features

- The joints of the valve body have good sealing performance. The valve body and the coil can be supplied as a whole or separately. The valve body is universal
- Various coil voltages are available, the coil power consumption is low, the reliability is high, the overall sealing design is adopted, and the protection level reaches IP65
- The maximum working pressure difference of the solenoid valve is large, it can work stably under the condition of voltage fluctuation, and has a long service life
- The solenoid valve is a detachable structure, which is extremely convenient for installation and maintenance

## Technical Parameters

Model	LFSV-K
Refrigerants	R22,R134a,R407C,R404A,R410A,R507C and other refrigerants
Medium temperature	-30°C~ +105°C
Environment temperature and humidity	-40°C~ +65°C, ≤95%RH
Coil standard voltage	AC220V, AC110V, DC24V, DC12V (contact LEFOO for other customized voltages)
Allowable Voltage Fluctuation for Solenoid	+10%~ -15%
Wiring	Standard DIN junction box
Installation position	Suction- exhaust port and liquid pipe port

## Valve body Technical data

structure	Model	Connection type	Pipe size (inch)	Kv (m <sup>3</sup> /h)	Max.working pressure (MPa)	Dimension (mm)					
						ΦD	M (UNF)	L1	L	A	H
Direct Operated	LFSV -K-2	SAE	1/4	0.2	4.5	-	7/16 -20	-	58	70	65
		ODF				6.5	-	7	90	70	65
	LFSV -K-3	SAE	3/8	0.27		-	5/8 -18	-	64	70	65
		ODF				10.1	-	8	104	70	65
LFSV -K-3	SAE	5/8		0.8		-	5/8 -18	-	87	70	72
	ODF					10.1	-	8	108	70	72
Diaphragm twice open	LFSV -K-4	SAE	1/2	2.6		-	3/4 -16	-	89	70	72
		ODF				12.8	-	10	114	70	72
	LFSV -K-5	SAE	5/8	2.6	-	7/8 -14	-	104	70	75	
		ODF			16.1	-	14	152	70	75	
	LFSV -K-6	SAE	3/4	2.6	-	1-1/16-14	-	104	70	75	
		ODF			19.2	-	16	158	70	75	
	LFSV -K-6	ODF	7/8	5.7	22.3	-	17	180	70	88	

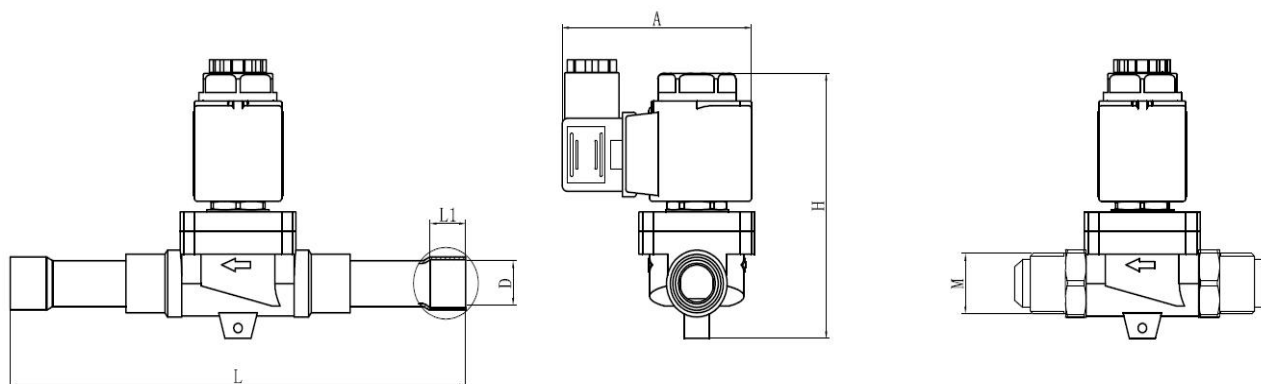

## Coils Technical Data

Model	Voltage (V)	Frequency (HZ)	Power consumption(W)	insulation grade	Voltage fluctuation	Protection Grade	Coil type
K-XQ01	DC24	-	10/9W	F	+10%~-15%	IP65	DIN junction box
K-XQ02	AC110	50/60					
K-XQ03	AC220						

Coil dimension:

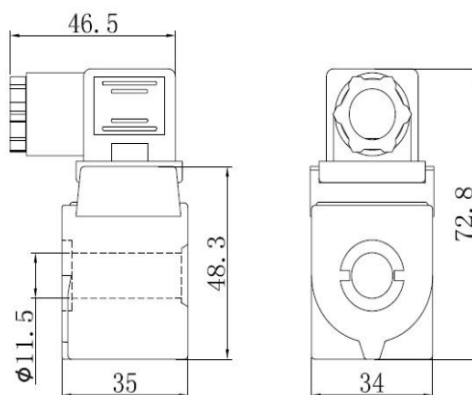

DIN junction box

# LFFDF

## Solenoid Valve



### Product Description

LFFDF series solenoid valves are divided into direct and servo-operated, and are mainly used for on-off control of refrigerants in refrigeration systems, air conditioners and heat pumps.

### Features

- The valve body adopts advanced welding technology and imported materials, which ensures that the valve body has almost no internal and external leakage
- Various coil voltages are available, with low coil power consumption, high reliability, and good opening performance
- The maximum working pressure difference of the solenoid valve is large, it can work stably under the condition of voltage fluctuation, and has a long service life
- The solenoid valve is small in size and goes out directly, which is very suitable for ice machines, ice cream machines, etc.

### Technical Parameters

Refrigerants	R22, R134a, R407C, R404A, R410A, and other refrigerants, clear water
Medium temperature	-30°C~+120°C
Environment temperature and humidity	-40°C~+65°C, ≤95%RH
Coil standard voltage	AC220V, AC110V, AC24V, DC12V
Allowable Voltage Fluctuation for Solenoid	+10%~-15%
Wiring	direct lead
Installation position	The suction-exhaust ports ,the liquid pipe port, and the coil, toward upward. The valve body is vertical (verticality is within ±15° deviation)

## Valve body Technical data

Specifications	code	Connection Diameter	Action type	Valve Diameter (mm)	Max Operating pressure Difference (Mpa)	Interior leak (ml/min)	Coil temperature	Life Time
LFFDF0.5	-001	φ6.35*47	Power Time To open	0.5	0.84	<10	<75K	200000 times
LFFDF2A	-001	φ6.35*69Inlet outlet flaring		2	3.4	<99		
	-05	φ6.35*47						
	-05A	φ6.35*69outlet flaring						
	-06	φ6.35*69Inlet flaring,outlet necking						
	-07	6.35*69outlet necking						
LFFDF3A	-001	6.35*47		3	2.8			
	-001A	6.35*47 outlet flaring						
	-01	φ6.35*72						
LFFDF4A	-001	φ6.35*47		4	2.8			
	-001A	φ6.35*47outlet flaring						
LFFDF6A	-001	φ8*58		6	3.4			
	-02	φ8*40						
LFFDF7A	-001	φ8*58	7	3.4	<100			

Inlet outlet flaring or necking can be customized

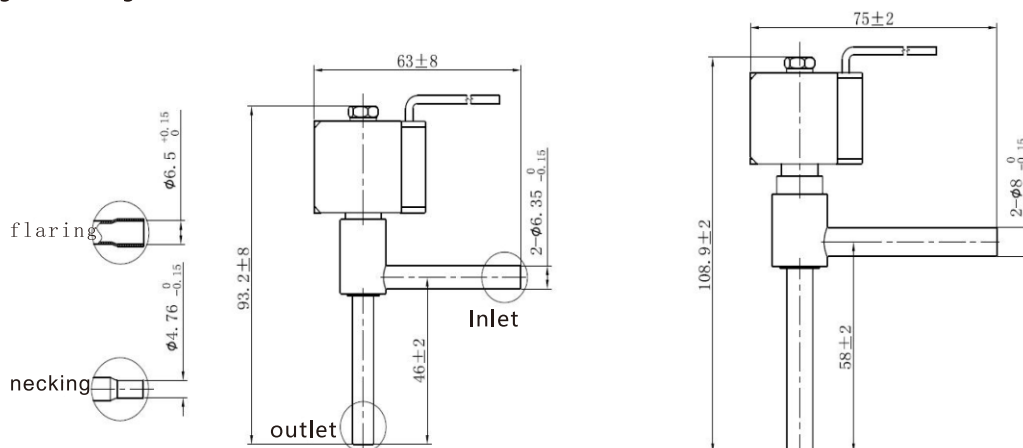

## Coils Technical Data

Model	Voltage(V)	Frequency (Hz)	Power (W)	insulation grade	Voltage fluctuation	Coil type	Standard line length
FDF-XQ01	DC24	-	4.5/5W	B	+10%~-15%	Direct lead	1m
FDF-XQ02	AC24	50/60					
FDF-XQ03	AC110						
FDF-XQ04	AC220						

Coil dimension:

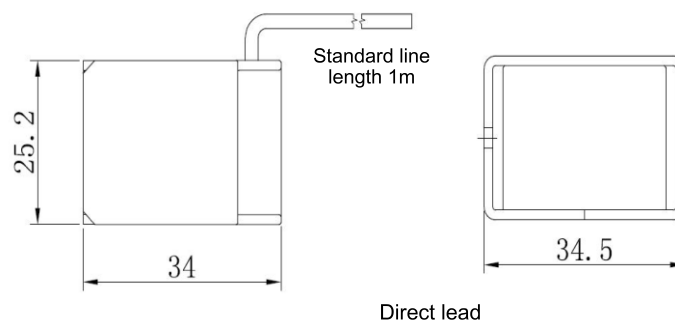

# LFBV

## Ball Valve

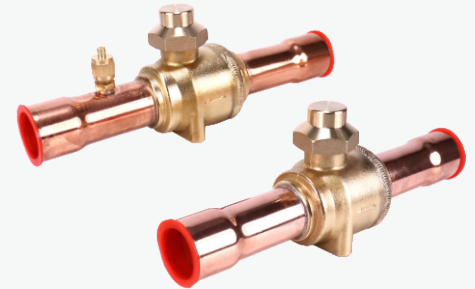
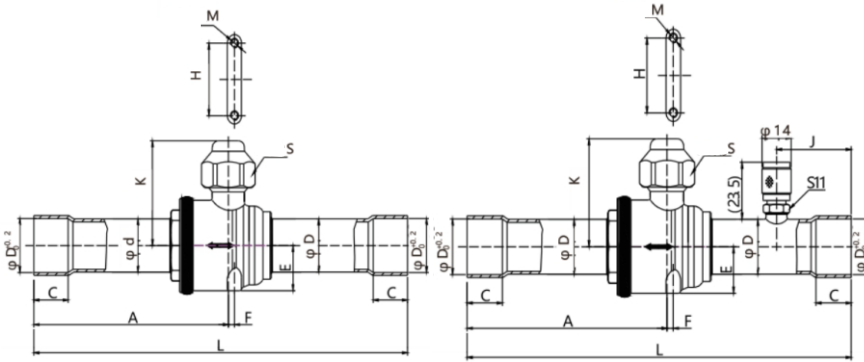

The LFBV ball valve is a manually adjusted Shut-off valve, suitable for two-way flow, used in the liquid, suction and hot vapor pipelines of freezer, refrigeration and air conditioning devices. The valve seat of Model LFBV ball valve is well sealed with perfect sealing technology. This ball valve is straight through type, is capable to provide maximum flow, at same time the valve has a wide operating temperature range, the ball valve is equipped with a sealing cap with secondary sealing function.

### Overall Dimension

Model	A	C	D	d	E	F	K	M	J	H	L
LFBV-6s	57	6	6.5	10	14	0	32.5	M4	20	44	110
LFBV-10s	65	8	10.1	10	14	0	32.5	M4	26	44	126
LFBV-12s	67	10	12.8	12	14	0	32.5	M4	26	44	130
LFBV-10	73	9	10.1	16	14.5	2	38	M4	30	50	138
LFBV-12	83	10	12.8	16	14.5	2	38	M4	30	50	159
LFBV-16	83	12	16.1	16	14.5	2	38	M4	30	50	159
LFBV-19	97	14	19.1	19	16.5	3	42	M4	36	58	185
LFBV-22	96	17	22.3	22	19	3	43	M4	36	58	185
LFBV-28	108	20	28.7	28	24	4	52.5	M4	44	66	208
LFBV-35	130	25	35.2	35	30	5	64	M6	44	80	251
LFBV-42	145	29	41.5	41.3	35	6	74	M6	56	87	281
LFBV-54	157	35	54.2	54	45.5	9	83.5	M6	56	106	305
LFBV-67	157	37	67	54	45.5	9	83.5	M6	63	106	305
LFBV-79	157	40	79.6	54	45.5	9	83.5	M6	63	106	305
LFBV-67A	171	37	67	66.8	54	16	94	M6	72	117	343
LFBV-79A	207	37	79.6	79.4	64	16	104	M6	80	117	413

### Model Selection

Model	Size	OD(mm)	Kv(m3/h)	Model	Size	OD(mm)	Kv(m3/h)
LFBV-6s	1/4(φ6)	10	2	LFBV-28	1-1/8(φ28)	φ25	52.0
LFBV-10s	3/8(φ10)	φ10	5.7	LFBV-35	1-3/8(φ35)	φ31	80
LFBV-12s	1/2(φ12)	φ10	5.7	LFBV-42	1-5/8(φ42)	φ37	121
LFBV-10	3/8(φ10)	φ14	5.7	LFBV-54	2-1/8(φ54)	φ50	200
LFBV-12	1/2(φ12)	φ14	10.6	LFBV-67	2-5/8(φ67)	φ50	200
LFBV-16	5/8(φ16)	φ14	14.1	LFBV-79	3-1/8(φ79)	φ50	200
LFBV-19	3/4(φ19)	φ16	20.4	LFBV-67A	2-5/8(φ67)	φ60.5	310
LFBV-22	7/8(φ22)	φ19	28.2	LFBV-79A	3-1/8(φ79)	φ73	700

### Technical Parameters

General	Value
Applicable Refrigerant	HCFC or HFC (Customer choice)
Applicable Medium Temperature	-40~+120°C
Max. Working Pressure	4.5MPa
Max. Compression Pressure	6.5MPa
Yearly Leakage of Refrigerant	≤2g R22/a

# LFSG

## Sight Glass

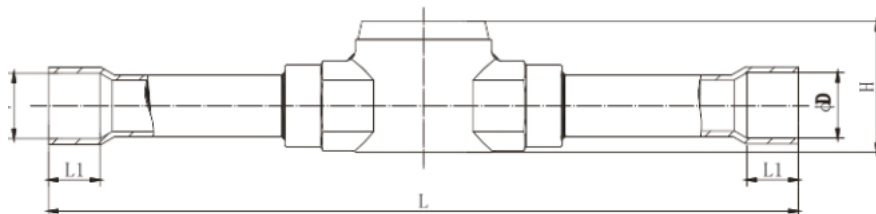
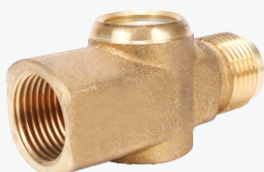

Soldering type sight glass

Model	L	L1	D	H
LFSG-1/4ODF	102	7	6.5	21.5
LFSG-3/8ODF	119	8	10.1	22.5
LFSG-1/2ODF	146	10	12.8	26.5
LFSG-5/8ODF	152	14	16.1	29.5

Model	L	L1	D	H
LFSG-3/4ODF	167	16	19.2	35
LFSG-7/8ODF	173	17	22.2	39
LFSG-1-1/8ODF	216	20	28.7	44.5

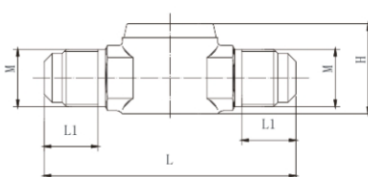

Flare type sight glass

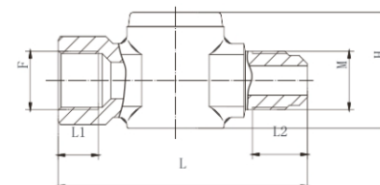

M/F type sight glass

Model	L	L1	D	H
LFSG-1/4 SAE	64	13	21.5	7/16-20UNF
LFSG-3/8 SAE	70	15	25	5/8-18UNF
LFSG-1/2 SAE	75	16	26.5	3/4-16UNF
LFSG-5/8 SAE	80	18	29.5	7/8-14UNF
LFSG-3/4 SAE	90	20.5	35	1-1/16-14UNF

Model	L	L1	L2	H	Thread F/M
LFSG-1/4-MF	60	8.5	12	25	7/16-20UNF
LFSG-3/8-MF	68	11	15	31.5	5/8-18UNF
LFSG-1/2-MF	70	11.5	16	34.5	3/4-16UNF
LFSG-5/8-MF	78	13	18	38	7/8-14UNF

Both Model LFSG sight glass is used on the liquid piping of the refrigeration and air conditioning unit to indicate the flow condition of the refrigerant, water cut of the refrigerant and lubricant oil flow condition of the oil return piping on the oil separator. Model LFSG sight glass and is equipped with one moisture indicator; which will change color to indicate the water cut in the refrigerant. Model LFSG sight glass is used to indicate the level of the refrigerant in the liquid drum and the lubricant oil level in the compressor crankcase. The modified PTFE sealing is used in both Model LFSG sight glass and Model LFSG sight glass, which is applicable to various refrigerants and oils with perfect sealing performance. The structure of both Model LFSG sight glass and Model LFSG sight glass is an explosion-proof press fit and the viewing glass is clear and safety.

### Model Selection

Model of Welded Connection	Size	Model of Threaded Connection	Size
LFSG-1/4 ODF	1/4(φ6)	LFSG-1/4 SAE	1/4 SAE
LFSG-3/8 ODF	3/8(φ10)	LFSG-3/8 SAE	3/8 SAE
LFSG-1/2 ODF	1/2(φ12)	LFSG-1/2 SAE	1/2 SAE
LFSG-5/8 ODF	5/8(φ16)	LFSG-5/8 SAE	5/8 SAE
LFSG-3/4 ODF	3/4(φ19)	LFSG-3/4 SAE	3/4 SAE
LFSG-7/8 ODF	7/8(φ22)	LFSG-3/4NPT	3/4NPT
LFSG-1 <sup>1</sup> / <sub>8</sub> ODF	1 <sup>1</sup> / <sub>8</sub> (φ28)	LFSG-G3/4	G3/4

### Technical Parameters

General	Value
Applicable Refrigerant	HCFC or HFC
Applicable Medium Temperature	-40~+80°C
MAX.Working Pressure	4.5MPa
MAX. Compression Pressure	6.8MPa
Yearly Leakage of Refrigerant	≤2g R22/a

# LFCV

## Charging Valve

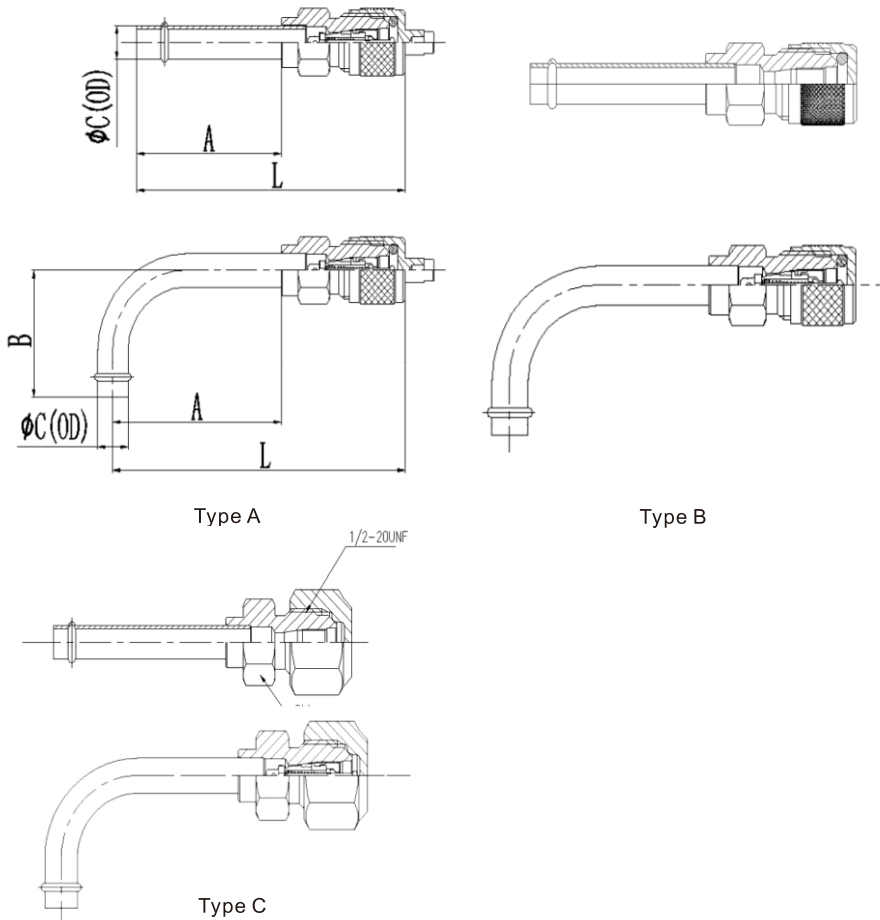
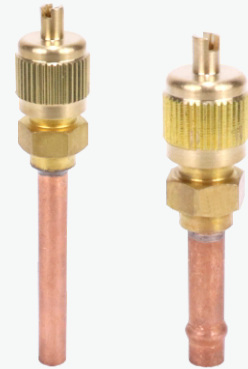

The charging valve is an one-way service valve with valve inside. The charging valve is used on the freezer; cold store and air - conditioning unit. Equipped with imported valve inside of reliable performance. Double sealing ensure leak-tight. Copper tube of various lengths and hardness are available. Valve bonnet is knurled for easy handling.

### Model Selection

Type	Connection Thread	Tubing	Suitable Refrigerant	Tubing Length	Tubing Length	Nozzle	Nozzle	Hexagonal	Length
	[Inch]	[Inch]		A	B	C	Y/N Limitation	S	L
Type A Thimble Nut	7/16-20UNF	1/4 "	R22	30	\	6.35	Y	11	55.5
	7/16-20UNF	1/4 "	R410A	30	\	6.35	Y	11	55.5
	7/16-20UNF	1/4 "	R22	50	\	6.35	Y	11	55.5
	7/16-20UNF	1/4 "	R410A	50	\	6.35	Y	11	55.5
Type B FHCS	7/16-20UNF	1/4 "	R22	35	24	6.35	Y	11	60.5
	7/16-20UNF	1/4 "	R22	30	\	6.35	Y	11	55.5
	7/16-20UNF	1/4 "	R410A	30	\	6.35	Y	11	55.5
	7/16-20UNF	1/4 "	R22	50	\	6.35	Y	11	55.5
	7/16-20UNF	1/4 "	R410A	50	\	6.35	Y	11	55.5
Type C S17Hexnut	1/2-20UNF	1/4 "	R410A	30	\	6.35	Y	14	55.5
	1/2-20UNF	1/4 "	R410A	35	24	6.35	Y	14	60.5

Note: Copper tube size accepts customization

### Technical Parameters

General	Value
Applicable Refrigerant	HCFC or HFC
Applicable Medium Temperature	-25°C~+120°C
Max. Operating Pressure	3.0MPa
Max. Allowable Pressure	4.5MPa

# LFTEV

## Thermostatic Expansion Valves

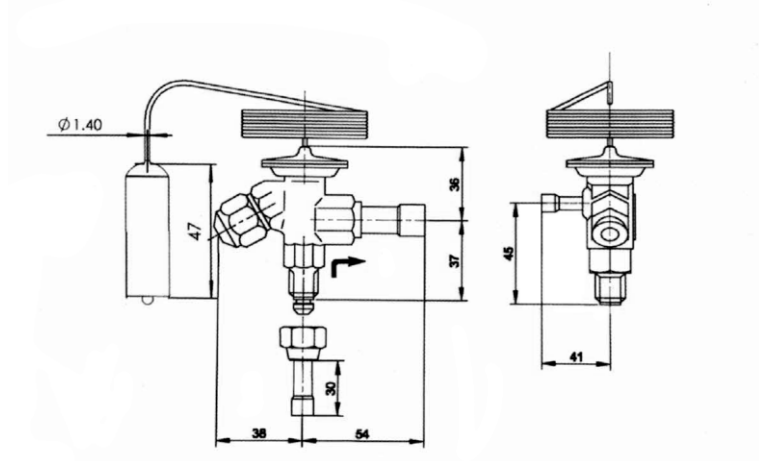

LFTEV is a kind of thermostatic expansion valve with interchangeable orifices suitable for automatic supply and regulation of the refrigerating agent of small and middle size dry evaporator. Constant superheat adjusting performance. Changeable orifice. Suitable for R22, R134a, R407C, R404A/R507. SAE or ODF connection. Evaporating temperature range:

Dimension in : mm

### Model Selection

LFTEV(T2\TE2) Expansion valve type & data

(separate or full set purchase, with Temperature sensing bulb fix fasten, valve core and connect nuts please separate purchase.)

Refrigerant	Model		balanced way	capillary vessel	connector		
					Inlet	Out let	Equalizing
					In/mm	In/mm	In/mm
R22	R22N-H	TX2	inner balance type	1500	3/8"/9.52	1/2"/12.7	
	R22W-H	TEX2	outer balance type	1500	3/8"/9.52	1/2"/12.7	1/4"/6.35
R407C	R407CN-H	TZ2	inner balance type	1500	3/8"/9.52	1/2"/12.7	
	R407CW-H	TEZ2	outer balance type	1500	3/8"/9.52	1/2"/12.7	1/4"/6.35
R134a	R134aN-H	TN2	inner balance type	1500	3/8"/9.52	1/2"/12.7	
	R134aW-H	TEN2	outer balance type	1500	3/8"/9.52	1/2"/12.7	1/4"/6.35
R404A/R507	R404A/R507N-H	TS2	inner balance type	1500	3/8"/9.52	1/2"/12.7	
	R404A/R507W-H	TES2	outer balance type	1500	3/8"/9.52	1/2"/12.7	1/4"/6.35

Mark: only outer balance type expansion valve have balance connector

### Orifice type & data

orifice	Nominal capacity (RT)				Nominal capacity (KW)			
	R22	R407C	R134A	R404A R507	R22	R407C	R134A	R404A R507
0X	0.15	0.16	0.11	0.11	0.5	0.5	0.4	0.38
00	0.3	0.3	0.25	0.21	1.0	1.0	0.9	0.7
01	0.7	0.6	0.5	0.45	2.5	2.7	1.8	1.6
02	1.0	1.1	0.8	0.6	3.5	3.8	2.6	2.1
03	1.5	1.6	1.3	1.2	5.2	5.6	4.8	4.2
04	2.3	2.5	1.9	1.7	8.0	8.6	6.7	6.0
05	3.0	3.2	2.5	2.2	10.5	11.3	8.6	7.7
06	4.5	4.9	3.0	2.6	15.5	16.7	10.5	9.1

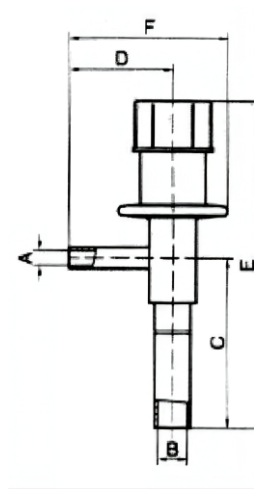

# LFDBV

Discharge-Bypass Valves

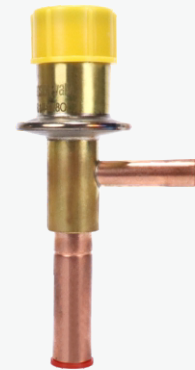

## Model Selection

### Dimensions and Weights

Model	valve size	Connections		Dimensions(mm)			
		Inlet(A)	Outlet(B)	C	D	E	F
LFDBV	0.5	6mmODF	10mmODF	58	36	106	54
	1.0						
	2.0	1/4"ODF	3/8"ODF	64	47	122	69
	3.0						
	4.0	3/8"ODF	5/8"ODF	64	47	122	69
	5.0						
6.0							

LFDBV discharge-bypass valve is a kind of load adjust component for the refrigerating system with a nonadjustable compressor. LFDBV discharge-bypass valve can be used as automatic expansion valve under fixed pressure to maintain the fixed evaporation pressure (temperature). LFDBV is capable of maintaining the minimum evaporating pressure. LFDBV discharge-bypass valve can automatically change the opening to get the constant outlet pressure on regardless of the change of the inlet pressure (within a certain range). ODF connecting. Maximum working pressure: 28bar.

### Capacities

Type	valve size	orifice size	Nominal capacity(kw)			
			R134a	R22	R404A	R507
LFDBV	0.5	0.7	0.98	1.4	1.0	1.0
	1.0	1.0	1.4	2.1	1.5	1.5
	2.0	2.0	2.9	4.2	3.0	3.0
	3.0	3.0	6.7	9.8	6.8	6.9
	4.0	3.5	8.9	12.8	9.0	9.0
	5	4.75	16.3	23.6	16.5	16.6
	6	5	20.4	30.6	21.4	21.6

# LFDCV

## Magnetic check valve

### Introduction

Magnetic check valve was designed with magnet diaphragm, and sealed by the metal. It was used on the exhaust pipe of the compressor. For inside, it uses guide device and automatic suction design that prevents reverse refrigerant flow in liquid lines and compressor discharge lines.



### Feature

- Magnet valve seat, tectorial diaphragm. Copper connection size 1/4"through 3-1/8".
- Near zero internal leak rate.
- Compatible with all CFC, HCFC and HFC refrigerants and oils.
- Working temperature range: -40°C~ +130°C.
- Minimum current resistance, large flow rate.
- Straight line shape, slim and light body, can be installed in any position.
- Mesh in the valve body, it's not just a check valve, but also a filter.

Type	Connection(in)	Safety working pressure (Kpa)	OD (mm)	Length (mm)	Mesh No.	Liquid refrigeration (KW)
DCV-4	1/4	5500	22	102	40	6.8
DCV-6	3/8	5500	22	102	40	14.2
DCV-8	1/2	5200	29	127	40	38.2
DCV-10	5/8	5200	29	127	40	42.6
DCV-12	3/4	4100	41	178	40	79.7
DCV-14	7/8	4100	41	178	40	108.5
DCV-18	1-1/8	4100	54	213	40	188.5
DCV-22	1-3/8	4000	67	238	40	232.8
DCV-26	1-5/8	3000	80	267	40	397.7
DCV-34	2-1/8	3200	92	305	40	691.1
DCV-42	2-5/8	3000	105	330	40	927.3
DCV-50	3-1/8	3000	105	330	40	1262.5

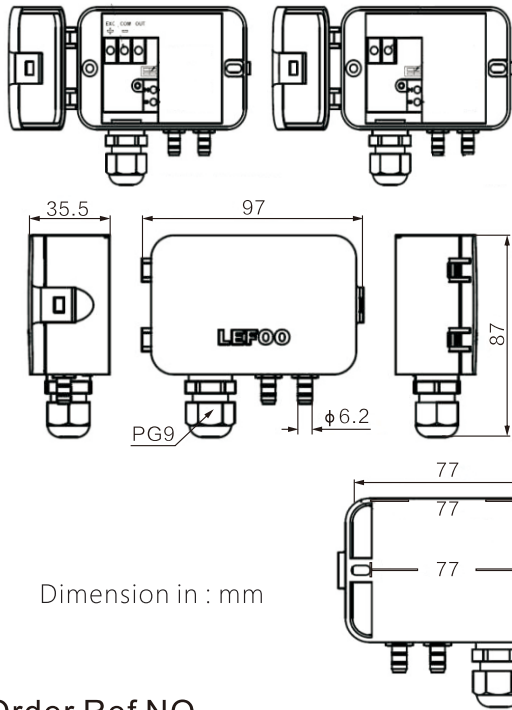

Dimension in : mm

# LFM108

Differential pressure transmitter



LFM108 differential pressure transmitter detect differential pressure or gauge pressure then convert this pressure difference to a proportional analogue output signal. Two output version are offered: Voltage output of 0~10VDC, and a current output 4-20mA. LFM108 differential pressure transmitter ranges from 0~±50Pa to 0~±10000Pa.

## LFM108 Order Ref NO

LFM108 - 101G or 051D - VZ

**A**      **B**      **C**

<b>A one-way</b>	<b>B two-way</b>	<b>C Output</b>
101G=0~100Pa	051D=0±50Pa	AL=4~20mA
251G=0~250Pa	101D=0±100Pa	VL=0~10VDC
501G=0~500Pa	251D=0±250Pa	VZ=0~5VDC
102G=0~1000Pa	501D=0±500Pa	MOD=RS485
252G=0~2500Pa	102D=0±1000Pa	MVL=RS485,0~10VDC
502G=0~5000Pa	252D=0±2500Pa	MVZ=RS485,0~5VDC
103G=0~10000Pa	502D=0±5000Pa	
	103D=0±10000Pa	

## Specification

MODEL	value			
Testing Medium	Air or neutral gas			
Pressure Range	±100Pa, ±1000Pa, ±10000Pa			
Overload Pressure	Maximum 15 times the rated pressure			
Accuracy	±1%F.S			
Stability	Typical value: 0.1%F.S Maximum value: 0.2%F.S			
Working Temp	-20°C~70°C			
Compensation Temp	-10°C~60°C			
Storage Temp	-40°C~70°C			
Response Time	0.5s/1.0s/2s/4s			
Protection Grade	Ip54			
Pressure Interface	Metal barbed interface, φ6.2mm			
Electrical Connectiona	2-wired	3-wired	4-wired	5-wired
Output Signal	4~20mA	0~5V 0~10V	Rs485	0~10VDC RS485
Power Supply	10~30VDC	16~30VDC	12~30VDC	16~30VDC
Power Consumption	≤1.5W			
Shell Material	UL94-V0/PC and ABS industrial plastics			
Communication	RS-485 standard interface, Modbus RTU protocol			
Certificaton	RoHS certification, CE certification			
Electromagnetic Compatibility	EN 61326-1			
Weight	140g			

# LFM11 Series

Differential pressure transmitter

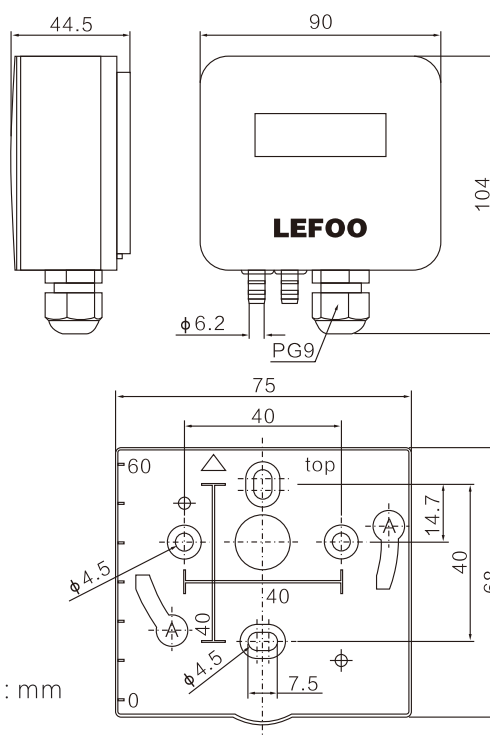

Dimension in : mm

Low Differential Pressure Transmitter LFM110/LFM112 are engineered for building automation in the HVAC/R industry , pressure and flow monitoring, and low differential pressure test in industry application.

## LFM11 Series Order Ref NO

LFM110 - N - A - C

A B C D

A Span	B Display	C Output	D Accuracy
0=-1000~1000Pa	O=with display	A=4~20mA and 0~10VDC(Simultaneous output)	±1.0%FS
2=-10000~10000Pa	N=without display	B=4~20mA(2-wired)(No backlight)	
6=-100~100Pa		C=0~10VDC(3-wired)	
		D=0~5VDC(3-wired)	
		E=RS-485 communication	
		F=0~10VDC&RS485	

## Specification

General	Value				
Testing Medium	Air or neutral gas				
Pressure Range	±100Pa, ±1000Pa, ±10000Pa				
Overload Pressure	5kPa(LFM116);10kPa(LFM110),80kPa(LFM112)				
Accuracy	±1%F.S	Protection Grade	Ip54		
Working Temp	-10°C~60°C	Storage Temp	-20°C~70°C		
Compensation Temp	-10°C~60°C	Response Time	0.5s/1s/2s/4s		
Pressure Connection	Metal barbed connection, Φ6.2 mm				
Electrical Connection	2-wired	3-wired	4-wired	5-wired	6-wired
	4-20mA (No backlight display)	0~5V 0~10V	Rs485	0~10VDC Rs485	4-20mA 0~5/10VDC
Power Supply	12~30VDC	16~30VDC	12~30VDC	16~30VDC	16~30VDC
Power Consumption	≤1.5W				
Shell Material	UL94-V0/ABS industrial plastic				
Communication	RS-485 Standard interface, Modbus RTU protocol				
Certification	RoHS Certification, CE certification				
Electromagnetic Compability	EN 61326-1				
Display Mode	LCD Backlight digital display				
Weight	166g				

# LFM32

micro-differential pressure instrument



Dimension in : mm



LFM32 Differential Pressure Transmitter/Controller adopts high-precision MEMS digital pressure sensor, which can detect positive pressure, negative pressure or differential pressure. It has 4-20 mA & 0-10V or RS485 signal output, and a variety of working mode settings to match the actual application requirements. Relay switch control is optional and can set pressure point independently. The internal buzzer and LED will indicate pressure alarm. Pressure unit switching and digital damping filter degree can be edited on site. It is widely used in air or neutral gas detection and control. It is suitable for air pressure detection of various ventilation and air conditioning systems and equipment, and for differential pressure detection of filter resistance in clean-room laboratories, and gas pipelines.

## LFM32 Order Ref No.

LFM32-0 A R P B  
A B C D E

A Measurement Range	B Signal output mode	C Control output	D Installation Panel	E Air Intake method
6: -100~100Pa	N:N/A	N:N/A	P: Plastic panel (round)	F: Front panel air intake
0: -1000~1000Pa	E: RS-485 Communication	R: 2 SPDT relay + 1X Buzzer	S: Stainless steel panel (square)	B: Rear panel air intake
2: -10000~10000Pa	A: 4~20mA and 0~10V	B: 1x Buzzer		S: Side panel air intake
		D: 2 SPDT relays		

## Specification

General	Value
Measured Medium	Air or neutral gas
Measurement range	±100Pa, ±1000Pa, ±10000Pa
Overload pressure	5KPa(LFM326); 10KPa(LFM320); 80KPa(LFM322);
Accuracy	±1%F.S
Working temperature	-10°C~60°C
Compensation temperature	-10°C~60°C
Storage temperature	-20°C~70°C
Protection level	Ip65
Pressure connection	Plastic concave interface Φ6.5mm
Signal output	4~20mA&0~10V      Rs485
Control relay	2SPDT relay 3A @ 250VAC/30VDC
Power supply	16~30VDC
Consumption	≤2.5W
Housing material	UL94-V0/ABS industrial plastic
Communication	RS-485 standard interface, Modbus RTU protocol
Certification	RoHS, EU, CE
Magnetic compatibility	EN 61326-1
Display	76*33mm LCD display
Weight	360g

# LFM52

## Differential Pressure Transmitter

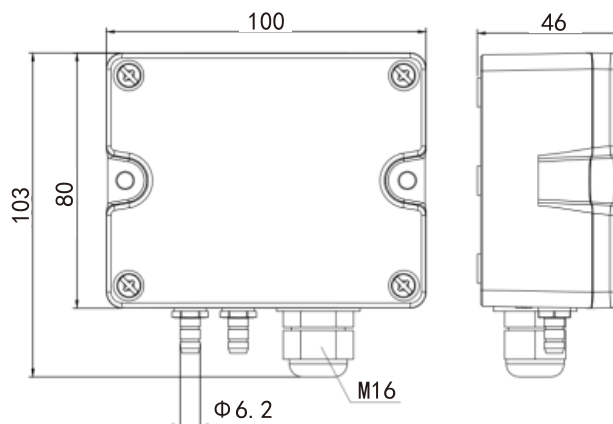

Dimension in : mm

LFM52 differential pressure transmitter is the latest release. It has flexibility of multi-range sensor, high function of single range sensor, and is ideal for industrial application. The differential pressure transmitter has built in multiple optional pressure range and unit selection, and is easily to adjust through built-in DIP switch. The shell protect is IP65 and equipped with stainless steel conduit for convenient wire arrangement. It is widely used in HVAC, energy management system, VAV and fan control, clean room pressure, smokehood control, oven pressurization, furnace ventilation, furnace ventilation control etc.

### LFM52 Series Order Ref NO

LFM52 - 6 - 0 - B

A B C

A Measurement Range	B Display mode	C Output Mode
6 = -100 ~ 100Pa	N = Without display	A = 4 ~ 20mA and 0 ~ 10VDC (Simultaneous output)
0 = -1000 ~ 1000Pa	0 = With display	B = 4 ~ 20mA (two-wired) (without backlight)
2 = -10000 ~ 10000Pa		C = 0 ~ 10VDC (3-wired)
		D = 0 ~ 5VDC (3-wired)
		E = RS-485 communication
		E1 = RS-485 communication (isolation output)

### Specification

General	Value			
Measured Medium	Air or Neutral gas			
Measurement Range	±100Pa, ±1000Pa, ±10000Pa			
Overload pressure	5kPa (LFM526); 10kPa (LFM520); 80kPa (LFM522);			
Accuracy	±1% F.S			
Working temperature	-20°C ~ 70°C	Compensation temperature	-10°C ~ 60°C	
Storage temperature	-40°C ~ 70°C			
Response time	0.5s (Default) / 1.0s / 2s / 4s			
Pressure connection	Ip65			
Pressure connection	Metal barbed interface, Φ6.2mm			
Electrical connection	2-wired	3-wired	4-wired	6-wired
Signal output	4 ~ 20mA (No backlight)	0 ~ 5VDC / 0 ~ 10VDC	RS-485	4 ~ 20mA & 0 ~ 10VDC
Power supply	12 ~ 30 VDC	12 ~ 30VDC / 24VAC + 20%	9 ~ 30VDC	12 ~ 30VDC / 24VAC + 20%
Power consumption	≤ 1.5W			
Housing material	UL94-V0/PC			
Communication	RS-485 standard interface, Modbus RTU protocol			
Certification	RoHS, CE	Electromagnetic compatibility	EN 61326-1	
Display	LCD backlight digital display			

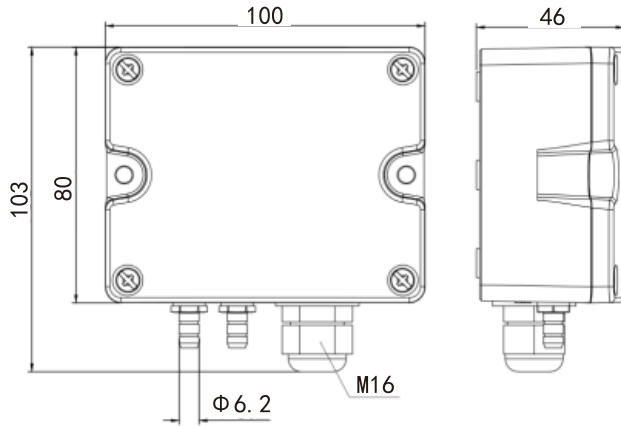

Dimension in : mm

# LFM53

## Differential Pressure Transmitter



The LFM 53 series differential pressure transmitter adopts the thermal micro -pressure core, use the micro-flowpath integrated by the sensor chip, detecting air pressure by detecting the changes in thermal flow. LFM53 has the characteristics of strong overload capacity, strong anti -interference ability, wide measurement range, and multi -signal output. It is widely used in the detection of air or neutral gas, such as HVAC, process control environmental control, clean room, clean room or other systems that require micro -differential pressure detection.

### LFM53 Order Ref No.

LFM53 - 1 - 0 - E  
**A B C**

A Measurement Range	B Display mode	C Output type
1=-25~25Pa	N=Without display	A=Output both 4-20mA and 0-10VDC
2=-50~50Pa	O=With display	E=RS-485 Communication
3=-100~100Pa		E1=RS-485(Isolated)

### Specification

General	Value	
Measured Medium①	Air or Neutral gas	
Pressure Range	±25Pa, ±50Pa, ±100Pa	
Overvoltage	2Bar	
Accuracy	±25Pa ±1Pa	
	±50Pa ±1%F.S	
	±100Pa ±0.5%F.S	
Working Temp	-20°C~70°C	
Storage Temp	-40°C~80°C	
Temp.Drift Value	0.03%FS/°C	
Protection Level	Ip65	
Electrical connections	4-wired	6-wired
Output signal	RS-485	4~20mA/0~10VDC
Power Supply②	9-30VDC/24VAC±20%	12-30VDC/24VAC±20%
Pressure Connection	Metal barbed interface, φ6.2mm	
Communication	RS-485 standard interface, Modbus RTU Protocol	
Certification	ROHS, CE	
Electromagnetic compatibility	EN 61326-1	

①Medium includes air, O2, N2, Ar, CO2, other gases, pls consult supplier.

②Pls use 24VAC isolated power supply for output RS485(non-isolated) when use AC power supply.

# LFM208

Residual pressure transmitter

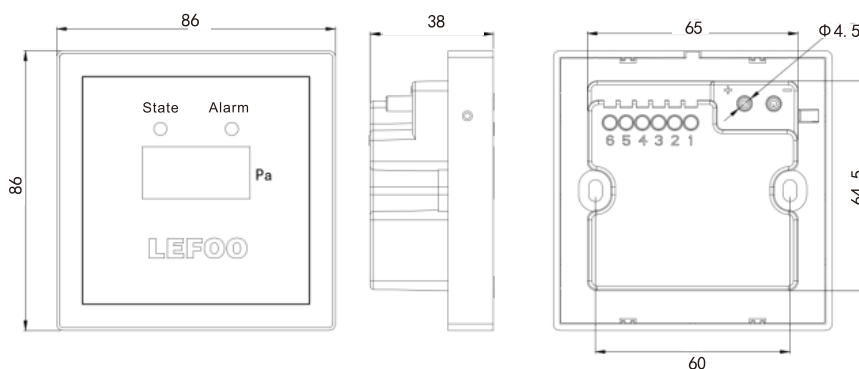

Dimension in : mm

LFM208 Residual Pressure Transmitter is a high-precision product, specially developed and designed for differential pressure controlling of high-rise building purging system. The core pressure monitoring element is American SMI differential chip. With zero point, full scale and temperature compensation can ensure the high accuracy, strong stability, and fully meet the pressure difference controlling of positive-pressure system. It has two signal lights, green is for working state, and red for alarm. This product adopts 24V DC power supply safety and low-voltage power supply: The optional two-bus method or 485 communication method, simple wiring, saving cost. The shape size of the product is 86\*86\*38, which can be fixed with the standard 86 bottom box, suitable for surface installation or embedded installation. This product is mainly used for the positive pressure air supply system in the elevator front room and the staircase. Product action pressure and reset pressure have been set before leaving the factory, no need to set on site. It greatly improves the accuracy of product control, and at the same time greatly reduces the construction workload of the scene. It is mainly used for differential pressure measurement and control system of elevator front room, shared front room, closed refuge floor, staircase and smoke proof staircase. It can also be used for indoor and outdoor differential pressure detection, filter blocking monitoring system and other dry gas differential pressure measurement and control system.

## LFM208 Order Ref No.

LFM208 2530 N P  
A B C

A Measurement Range	B Display Screen	C Communication
2530=20~30Pa	N=Without display	R=RS485
4050=40~50Pa	D=with display	P=Pb two-bus

## Specification

General	Value
Medium	Air and non-aggressive gas
Pressure Range	±100Pa
Withstand Pressure	1000Pa
Accuracy(a)	±1%F.S
Operation Temp.	-10°C~60°C
Compensated Temp	-10°C~60°C
Atorage Temp.	-20°C~75°C
Protection Level	Ip30
Power Supply	24VDC±10%
Inner Port Connection	Inner Dia Φ3.5mm hose
Hose Connection	(+) High Voltage, (-) Low Voltage
Indicator light	Green state light, red alarm light
Display	With/without
Communication	Two-bus (2-wired)/RS-485(4-wired)

a)Accuracy measured at 25°C

# LFT700

## Series-Pressure Transmitter

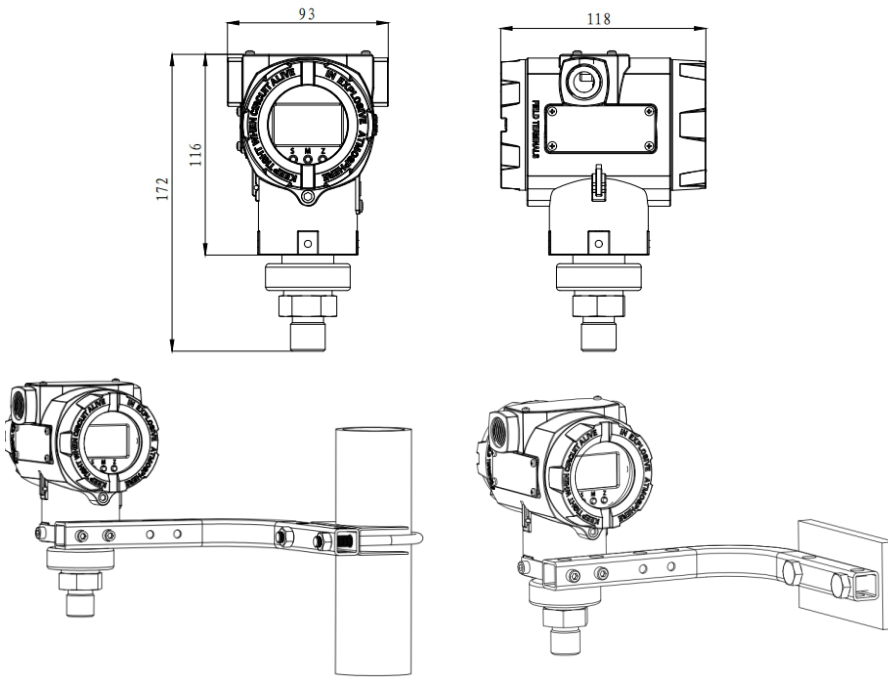

Dimension in : mm



LFT700 pressure transmitter is used to measure the liquid level density and pressure of liquid, gas or steam, then convert it to 4-20mA DC output signal. The transmitter can be operated locally with three buttons, or remotely operated by a universal hand operator, configuration software, and mobile phone APP. It can perform display and configuration adjustments without affecting the output signal of 4~20mA DC

### LFT700 Order Ref No

LFT700-

**A Measuring range** B=0-200Pa~6KPa(0-20~600mmH<sub>2</sub>O)/(0-2~60mbar) ,C=0-400Pa~40KPa(0-40~4000mmH<sub>2</sub>O)/(0-4~400mbar)

D=0-2.5KPa~250KPa(0-0.25~25mH<sub>2</sub>O)/(0-25~2500mbar) ,E=0-10KPa~1MPa(0-1~100mH<sub>2</sub>O)/(0-0.1~10bar)

F=0-30KPa~3MPa(0-3~300mH<sub>2</sub>O)/(0-0.3~30bar) ,G=0-100KPa~10MPa(0-10~1000mH<sub>2</sub>O)/(0-1~100bar)

**B Diaphragm material** S=316L,H=Hastelloy C,T=Tantalum

**C Filling liquid** D=Silicone oil

**D Electrical connection** 1=M20\*1.5 female thread, PVC,2=M20\*1.5 female thread, stainless steel,3=1/2NPT female thread, PVC,4=1/2NPT female thread, stainless steel

**E Output** N=4~20mA,J=4~20mA+HART,F=RS485

**F Process connection** M=M20\*1.5 male thread, G=G1/2 male thread, N=NPT1/2 female thread, A=NPT1/2 male thread ,Y=others

**G Mounting brackets** N=No stand,B4=Pipe bend bracket (carbon steel),B5=Flat bend bracket (carbon steel)

**Explosion-proof treatment** N=Normal type,D=Secondary Explosive ExdIICT6

**Display** M5=With display N=No display

**Additional requirements** P=M20\*1.5 female thread with pressure welding head,N=Connector material is 304, optional 316L

K=Degreasing and cleaning treatment, L=Hanging number plate,H=Lightning protection (transient voltage resistance)

E=English nameplate,V2=Two valve group

## FEATURES

- High-precision pressure sensor using MEMS monocrystalline silicon
- Fast response time, high stability, measurement accuracy 0.075%FS
- Turndown ratio up to 100:1
- Provide standard HART bus communication mode, perfect self-diagnosis and remote communication function
- High brightness LCD display with backlight, reversible in-place display screen
- In-place zeroing function, in-place zero point, full point setting and adjustment function
- Convenient in-place current loop calibration function
- Various types of connection
- RS-485 and 4~20mA HART output mode

## ELECTRICAL CONNECTION

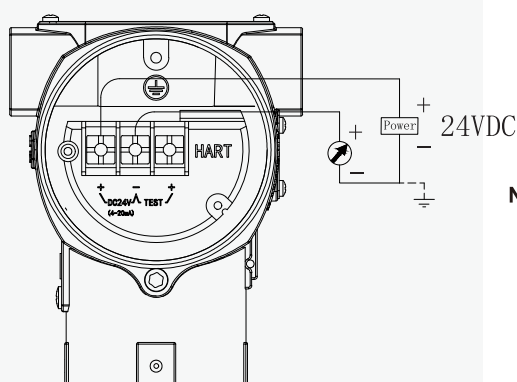

**Note:** The function of the shortcut interface is equivalent to the signal terminal.

## Specification

General	Value		
Measurement Range	6KPa,40KPa,250KPa,1MPa,3MPa,10MPa		
Overload Pressure	6KPa(400KPa),40KPa(1MPa),250KPa(4MPa),1MPa(6MPa),3MPa,10MPa		
Accuracy	±0.075%F.S		
Stability	±0.2%of the upper range		
Operating temperature	-20~70°C with display		
Storage temperature	-40~85°C		
Media to be measured	Gas, liquid		
Diaphragm material	316L, Hastelloy C, tantalum.		
Electrical Performance	2-wired		4-wired
Output Signal	4~20mA	4~20mA HART	RS485
Power Supply	12~36VDC	12~36VDC	12~36VDC
Electrical Connection	M20*1.5 waterproof outlet wire, NPT1/2 waterproof outlet wire		
Enclosure protection level	Ip65		
Pressure interface	M20*1.5 male thread, NPT1/2 female thread, NPT1/2 male thread, G1/2 male thread, others		
Pressure type	Gauge pressure G		
Certification items	ExdIICT6,CE		

# LFT710

## Differential Pressure Transmitter

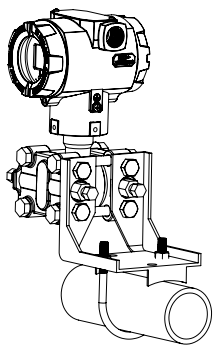

Pipe Mounted Horizontal Bracket

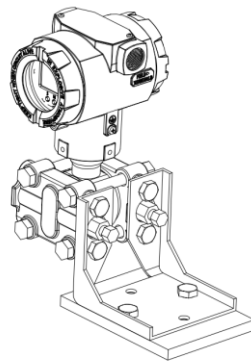
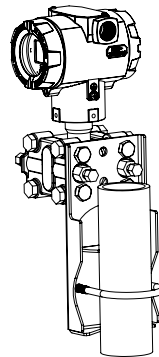
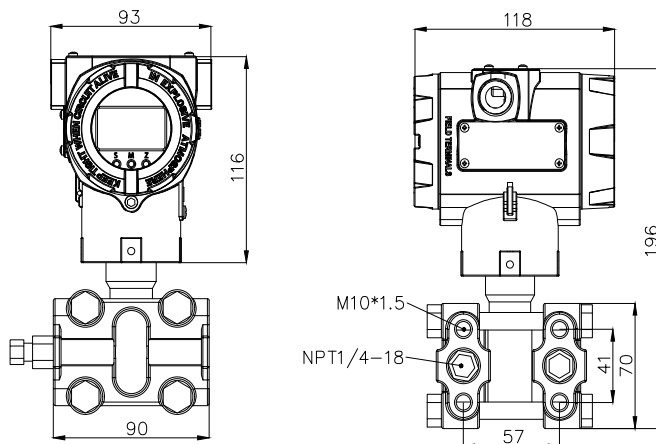

Plate Bending Bracket



Pipe Mounted Vertical Bracket



Dimension in : mm

LFT710 Differential Pressure Transmitter uses single crystal silicon sensor chip which adopts German advanced MEMS technology. It has built-in temperature compensation element and extremely high measurement accuracy and long-term stability over a wide range of static pressure and temperature variations. It can measure level, density, pressure of liquid gas and steam. It is widely used in industrial process control, automated manufacturing, aerospace automotive and marine petroleum and petrochemical, electronic power, medical and health and many other fields. LFT710 can accurately measure differential pressure and convert it into 4-20 mA DC output signal and can be operated locally through three buttons, and remotely operated by a general-purpose communicator, configuration software, and mobile phone APP, to perform display and configuration adjustment without affecting the 4-20 mA DC output signal.

### LFT710 Order Ref No

LFT710-C S D 1 J A D B1 D M5 P

- A Measuring range** B=0-200Pa~6KPa(0-20~600mmH<sub>2</sub>O)/(0-2~60mbar), C=0-400Pa~40KPa(0-40~4000mmH<sub>2</sub>O)/(0-4~400mbar)  
D=0-2.5KPa~250KPa(0-0.25~25mH<sub>2</sub>O)/(0-25~2500mbar), E=0-10KPa~1MPa(0-1~100mH<sub>2</sub>O)/(0-0.1~10bar), F=0-30KPa~3MPa(0-3~300mH<sub>2</sub>O)/(0-0.3~30bar)
- B Diaphragm material** S=316L, H=Hastelloy C, T=Tantalum
- C Filling liquid** D=Silicone oil
- D Electrical connection** 1=M20\*1.5 female thread, PVC, 2=M20\*1.5 female thread, stainless steel, 3=1/2NPT female thread, PVC, 4=1/2NPT female thread, stainless steel
- E Output** N=4~20mA, J=4~20mA+HART, F=RS485
- F Process connection** N=Without(NPT 1/4 female thread on chamber flange, A=Back welded connector and M20\*1.5 male  
B=Oval Flange connector: NPT1/2 Female, C=T type: M20\*1.5 male and back welded connector
- G Sealing ring** N=NBR, D=FKM, I=EPDM
- Mounting brackets** B1=Plate Bending Bracket(Carbon Steel), B2=Tube Bending Bracket(Carbon Steel) B3=Tube Flat Bracket(Carbon Steel)  
B5=Plate Bending Bracket(Stainless steel), B6=Tube Bending Bracket(Stainless steel), B7=Tube Flat Bracket(Stainless steel), N=Without
- Explosion-proof treatment** N=General, D=ExdIICT6
- Display** M5=With N=Without
- Additional requirements** P=M20\*1.5 male with welded connector, N=Connection parts is made of SS304, and SS316L is optional  
K=Degreasing cleaning treatment, L=Hanging number plate, H=Lightning protection(withstand transient voltage)  
E=English Nameplate, V3=Three valve block, V5=Five valve block

## FEATURES

- High-precision pressure sensor using MEMS monocrystalline silicon
- Fast response time, high stability, measurement accuracy 0.075%FS
- The maximum range ratio can reach 100:1
- Adopt double overload protection technology, strong overload capacity, one-way pressure up to 10MPa
- Provide standard HART bus communication mode, perfect self-diagnosis and remote communication function
- High brightness LCD display with backlight, reversible local display screen
- Convenient in-place current loop calibration function
- In-place zeroing function, in-place zero point, full point setting and adjustment function
- RS-485 and 4~20mA HART two output modes

## ELECTRICAL CONNECTION

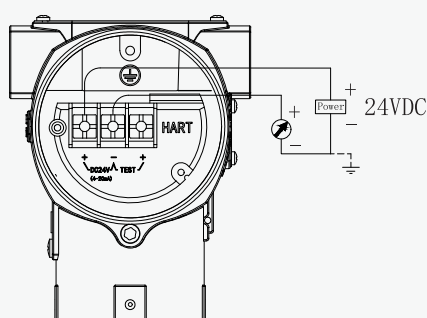

**Note:** The shortcut interface is functionally equivalent to the signal terminal.

## Specification

General	Value		
Measurement Range	6KPa,40KPa,250KPa,1MPa,3MPa		
Overload Pressure	Single-sided overload pressure of 16MPa		
Static pressure	10MPa,16MPa,25MPa		
Accuracy	±0.075%F.S		
Stability	±0.2%of the upper range		
Operating temperature	-20~70°C with display		
Storage temperature	-40~85°C		
Media to be measured	Gas, liquid		
Diaphragm material	316L, Hastelloy C, tantalum.		
Electrical Performance	2-wired	4-wired	
Output Signal	4~20mA	4~20mA HART	RS485
Power Supply	12~36VDC	12~36VDC	12~36VDC
Electrical Connection	M20*1.5 waterproof outlet wire, NPT1/2 waterproof outlet wire		
Enclosure protection level	Ip65		
Pressure interface	H-type construction with NPT1/4 female thread on chamber flange, with pilot fitting, with waist flange		
Pressure type	Gauge pressure G		
Certification items	ExdIICT6,CE		

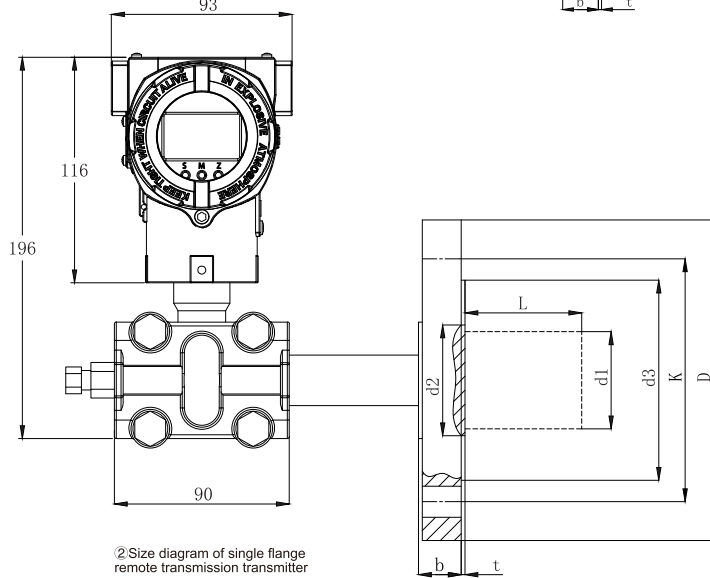
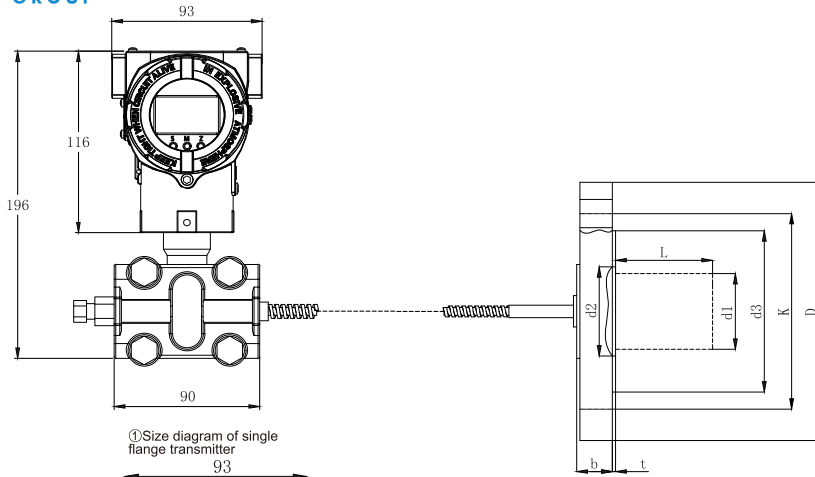

Dimension in : mm

# LFT720A

## Single Flange-mount Remote Pressure Transmitter



LFT720 Flange-mounted Transmitter is composed of LFT710 Differential Pressure Transmitter and a welded liquid level flange. Between the flange and the sensor, silicon oil and other filling fluids are used to transmit pressure, to prevent the measured medium from passing through the impulse pipe then impact the measurement. The impact of the measured medium pass through the impulse pipe includes: crystallization, solidification, vaporization (boiling)condensation, fractionation (severe change) and etc. The transmitter is used to measure the liquid level, flow and pressure of liquid, gas or steam, and then convert it into 4-20mA signal output. The working principle of the LFT720 Flange-mounted Transmitter is the same as LFT710 Differential Pressure Transmitter except that the pressure transmission path on the positive pressure side is slightly different, that is the pressure acting on the high-pressureside first passes through the diaphragm of the liquid level flange and the filling liquid, and then pass through the transmitter body. and finally reach the high pressure side of the measuring sensor.

### FEATURES

- High-precision pressure sensor using MEMS monocrystalline silicon
- Fast response time, high stability, measurement accuracy 0.075%FS
- Provide standard HART bus communication mode, perfect self-diagnosis and remote communication function
- High brightness LCD display with backlight, reversible local display screen
- Local zeroing function, local zero point, full point setting and adjustment function
- Convenient in-place current loop calibration function
- Various process connection options available according to requirements

### Specification

General	Value	
Measurement Range	6KPa,40KPa,250KPa,1MPa,3MPa	
Accuracy	±0.075%F.S	
Stability	±0.2%of the upper range	
Operating temperature	-20~70°C with display	
Storage temperature	-40~85°C	
Media to be measured	Gas, liquid	
Diaphragm material	316L, Hastelloy C, tantalum.others	
Electrical Performance	2-wired	
Output Signal	4~20mA	4~20mA HART
Power Supply	12~36VDC	12~36VDC
Electrical Connection	M20*1.5 waterproof outlet wire, NPT1/2 waterproof outlet wire	
Enclosure protection level	Ip65	
Pressure interface	Flange PN series, flange class series, other	
Pressure type	Gauge pressure G	
Certification items	ExdIICT6,CE	

## ELECTRICAL CONNECTION

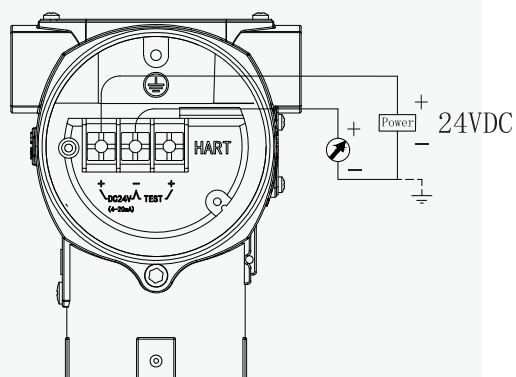

**Note:** The quick interface function is equivalent to the signal terminal.

## PROCESS CONNECTION DESCRIPTION

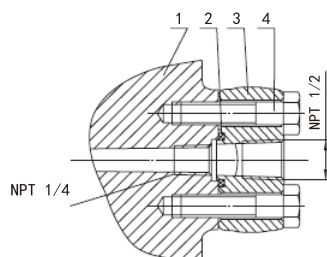

• 1/2-NPT stainless steel oval flange (code 1)

**comment:**  
1. Pressure chamber flange  
2. O-shaped seal diagram  
3. NPT1/2 oval with flange  
4. bolt

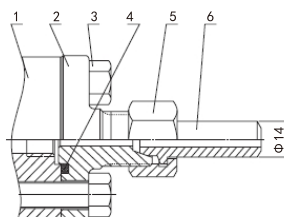

• M20x1.5 stainless steel T-shaped joint (code 2)

**comment:**  
1. Pressure chamber flange  
2. M20x 1.5 T-shape  
3. Male thread connector  
4. O-ring, sealing ring  
5. Nut M20x15  
6. Impulse tube

## LFT720A Order Ref No

### 1. Differential pressure single flange (selection)

**range** C=0-400Pa~40KPa(0-40~4000mmH<sub>2</sub>O)/(0-4~400mbar),D=0-2.5KPa~250KPa(0-0.25~25mH<sub>2</sub>O)/(0-25~2500mbar)

E=0-10KPa~1MPa(0-1~100mH<sub>2</sub>O)/(0-0.1~10bar),F=0-30KPa~3MPa(0-3~300mH<sub>2</sub>O)/(0-0.3~30bar)

**Diaphragm material** S=316L,H=Hastelloy C (insert cylinder does not have this option),T=Tantalum (insert barrel does not have this option)

**Process Fill Fluid** D=Normal temperature silicone oil(-40~205°C),C=High temperature silicone oil(0~315°C)

**Electrical Interface** 1=M20x1.5 female thread, PVC,2=M20x1.5 female thread, stainless steel,3=1/2NPT female thread, PVC,4=1/2NPT female thread, stainless steel

**Flange Standard** N=HG-T20592-2009(Steel pipe flange PN series)(Quoting European DIN system standard)

J=HG-T20615-2009(Steel pipe flange Class series(refer to American ANSI system standard),F=Other Flange Standards

**Flange Size** 3=DN50 2inch,4=DN80 3inch,5=DN100 3inch,6=OTHER

**Nominal Pressure Rating** 1=PN2.5、PN6,2=PN10、PN16 Class150(1b),3=PN25、PN40Class300(1b),Y=Other

**Insertion Barrel Extension Length** 0=0(without insert barrel),2=50mm,4=100mm,6=150mm,8=200mm,Y=special requirements

**Explosion-Proof Treatment** N=normal type, D=Flameproof ExdIICT6

**Display** M5=with display,N=no display

**Additional Requirements** P=The material of the chamber flange is 304, 316L is optional

N=Bolts and nuts are made of colored zinc, stainless steel is optional,K=Degreasing and cleaning treatment, L=Hanging number plate

H=Lightning protection(transient voltage resistance),E=English nameplate

### 2. Differential pressure double flange (option)

**range** C=0-4KPa~40KPa(0-400~4000mmH<sub>2</sub>O)/(0-40~400mbar),D=0-5KPa~250KPa(0-0.5~25mH<sub>2</sub>O)/(0-50~2500mbar)

E=0-100KPa~1MPa(0-10~100mH<sub>2</sub>O)/(0-1~10bar)

**Diaphragm material** S=316L,H=Hastelloy C (insert cylinder does not have this option),T=Tantalum (insert barrel does not have this option),Y=special requirements

**Process Fill Fluid** D=Normal temperature silicone oil(-40~205°C),C=High temperature silicone oil(0~315°C)

**Electrical Interface** 1=M20x1.5 female thread, PVC,2=M20x1.5 female thread, stainless steel,3=1/2NPT female thread, PVC,4=1/2NPT female thread, stainless steel

**Flange Standard** N=HG-T20592-2009(Steel pipe flange PN series)(Quoting European DIN system standard)

J=HG-T20615-2009(Steel pipe flange Class series(refer to American ANSI system standard),F=Other Flange Standards

**Flange Type** P=Flat type (only DN50, 2 inches and above),R=Flange Type,E=Insert barrel type (only DN80, 2 inches and above)

**Flange Size** 1=DN25 1Inch,2=DN40 1 1/2 Inch,3=DN50 2Inch,4=DN80 3Inch,5=DN100 4Inch,6=OTHER

**Nominal Pressure Rating** 1=PN2.5、PN6 Class150(1b),2=PN10、PN16 Class300(1b),3=PN25、PN40,Y=special requirements

**Insertion Barrel Extension Length** 0=0(without insert barrel),2=50mm,4=100mm,6=150mm,8=200mm,Y=special requirements

**High pressure H end capillary length** The length of the capillary is from 1 to10m, represented by (Example: 4m, 04)

**low pressure L end capillary length** The length of the capillary is from 1 to10m, represented by (Example: 4m, 04)

**Explosion-Proof Treatment** N=Ordinary type, D=Exproof ExdIICT6

**Display** M5=with display,N=no display

**Additional Requirements** B=Mounting brackets,P=The material of the chamber flange is 304,316L is optional

N=Bolts and nuts are made of colored zinc stainless steel is optional,K=Degreasing and cleaning treatment, L=Hanging number plate

H=Lightning protection(transient voltage resistance),E=English nameplate

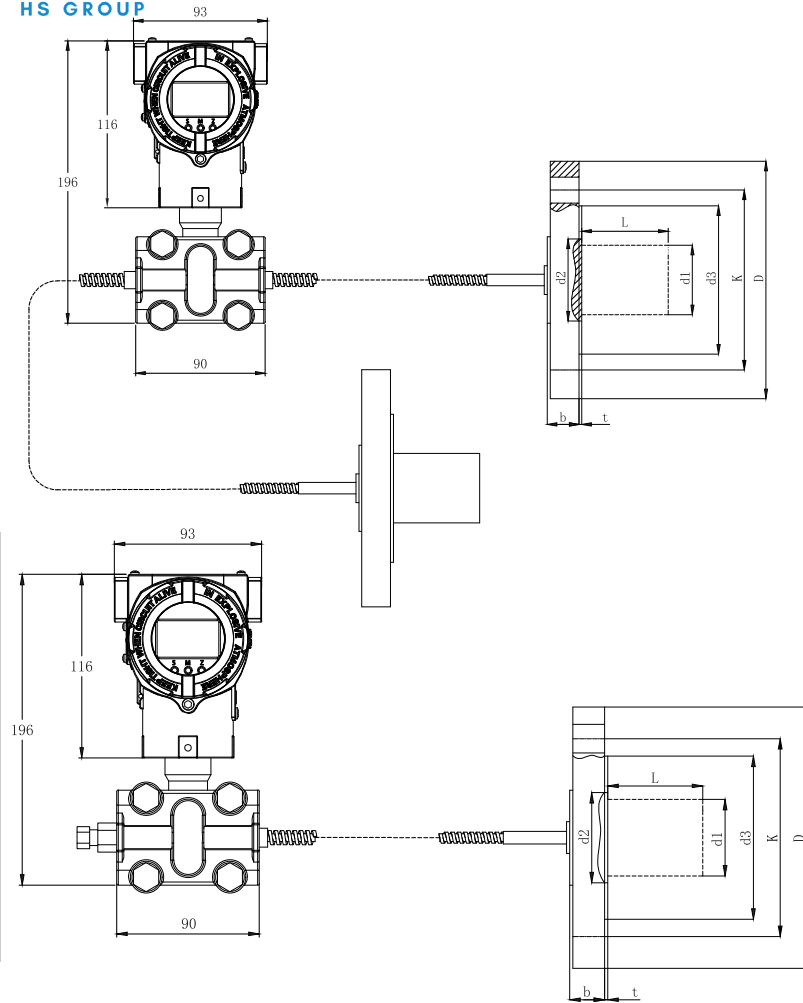

Dimension in : mm

# LFT720B

## Double Flange-mount Remote Pressure Transmitter



LFT720 Remote Flange Transmitter is composed of the LFT710 Differential Pressure Transmitter and a small welded remote flange with a capillary tube. Between the flange and the sensor, silicon oil and other filling fluids are used to transmit pressure, to prevent the measured medium from passing through the impulse pipe. Which will impact the measurement. The impact of the measured medium passing through the impulse pipe includes crystallization solidification, vaporization (boiling), condensation fractionation (severe change) and etc. The Transmitter is used to measure the liquid level, flow and pressure of liquid, gas or steam, and then convert it into 4-20 mA signal output. The working principle of LFT720 Flange Transmitter is the same as LFT710 Differential Pressure Transmitter except that the pressure transmission path on the positive pressure side is slightly different, that is the pressure acting on the high- pressure side firstly passes through the diaphragm and the filling liquid of the remote flange, and then pass to the transmitter body via capillary tube. and finally reach the high pressure side of measurement sensor

### FEATURES

- High-precision pressure sensor using MEMS monocrystalline silicon
- Fast response time, high stability, measurement accuracy 0.075%FS
- Provide standard HART bus communication mode, perfect self-diagnosis and remote communication function
- Convenient in-place current loop calibration function
- Local zeroing function, local zero point, full point setting and adjustment function
- Various process connection options available according to requirements
- High brightness LCD display with backlight, reversible local display screen

### Specification

General	Value	
Measurement Range	40KPa,250KPa,1MPa,3MPa	
Accuracy	±0.075%F.S	
Stability	±0.2%of the upper range	
Operating temperature	-20-70°C with display	
Storage temperature	-40~85°C	
Media to be measured	Gas, liquid	
Diaphragm material	316L, Hastelloy C, tantalum.others	
Electrical Performance	2-wired	
Output Signal	4~20mA	4~20mA HART
Power Supply	12~36VDC	12~36VDC
Electrical Connection	M20*1.5 waterproof outlet wire, NPT1/2 waterproof outlet wire	
Enclosure protection level	Ip65	
Pressure interface	Flange PN series, flange class series, other	
Pressure type	Gauge pressure G	
Certification items	ExdIICT6,CE	

## ELECTRICAL CONNECTION

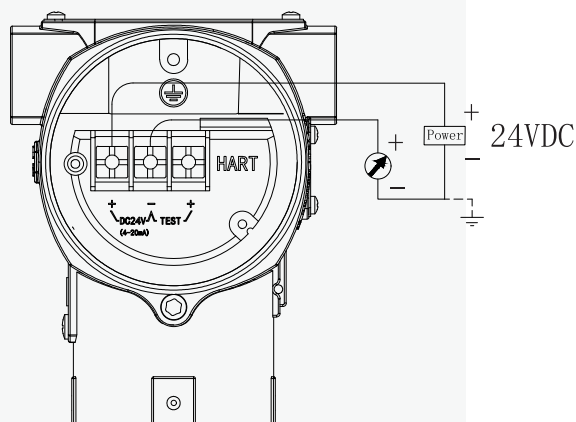

- **Note:** The quick interface function is equivalent to the signal terminal.

## PROCESS CONNECTION DESCRIPTION

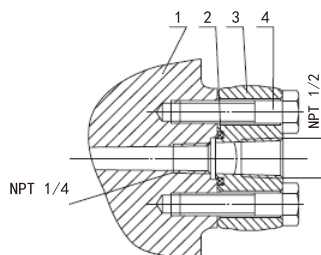

- 1/2-NPT stainless steel oval flange (code 1)

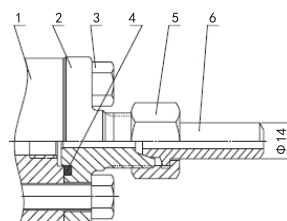

- M20x1.5 stainless steel T-shaped joint (code 2)

- comment:**
1. Pressure chamber flange
  2. O-shaped seal diagram
  3. NPT 1/2 oval with flange
  4. bolt

- comment:**
1. Pressure chamber flange
  2. M20x 1.5 T-shape
  3. Male thread connector
  4. O-ring, sealing ring
  5. Nut M20x15
  6. Impulse tube

## LFT720B Order Ref No

### 1. Differential pressure monoflange remote transmission (selection)

**range** C=0-4KPa~40KPa(0-400~4000mmH<sub>2</sub>O)/(0-40~400mbar),D=0-5KPa~250KPa(0-0.5~25mH<sub>2</sub>O)/(0-50~2500mbar)

E=0-100KPa~1MPa(0-10~100mH<sub>2</sub>O)/(0-1~10bar),F=0-300KPa~3MPa(0-30~300mH<sub>2</sub>O)/(0-3~30bar)

**Diaphragm material** S=316L,H=Hastelloy C (insert cylinder does not have this option),T=Tantalum (insert barrel does not have this option),Y=special requirements

**Process Fill Fluid** D=Normal temperature silicone oil(-40~205°C),C=High temperature silicone oil(0~315°C)

**Electrical Interface** 1=M20\*1.5 female thread, PVC,2=M20\*1.5 female thread, stainless steel,3=1/2NPT female thread, PVC,4=1/2NPT female thread, stainless steel

**Flange Standard** N=HG-T20592-2009(Steel pipe flange PN series)(Quoting European DIN system standard)

J=HG-T20615-2009(Steel pipe flange Class series(refer to American ANSI system standard),F=Other Flange Standards

**Flange Type** P=Flat type ,R=Flange Type, E=Insert barrel type (DN25, DN40,1 inch, 1 1/2 inch not available)

**Flange Size** 1=DN25 1Inch,2=DN40 1 1/2 Inch,3=DN50 2Inch,4=DN80 3Inch,5=DN100 4Inch,6=OTHER

**Nominal Pressure Rating** 1=PN2.5、PN6,2=PN10、PN16 Class150(1b),3=PN25、PN40 Class300(1b),Y=special requirements

**Insertion Barrel Extension Length** 0=0(without insert barrel),2=50mm,4=100mm,6=150mm,8=200mm,Y=special requirements

**High pressure H end capillary length** The length of the capillary is from 1 to10m, represented by (Example: 4m, 04)

**Explosion-Proof Treatment** N=Normal type, D=Flameproof ExdIICT6

**Display** M5=with display,N=no display

**Additional Requirements** B=Mounting brackets,P =The material of the chamber flange is 304,316L is optional

N=Bolts and nuts are made of colored zinc ,stainless steel is optional, K=Degreasing and cleaning treatment, L=Hanging number plate

H=Lightning protection(transient voltage resistance),E=English nameplate

# LFT2000

## General Type Pressure Transmitter

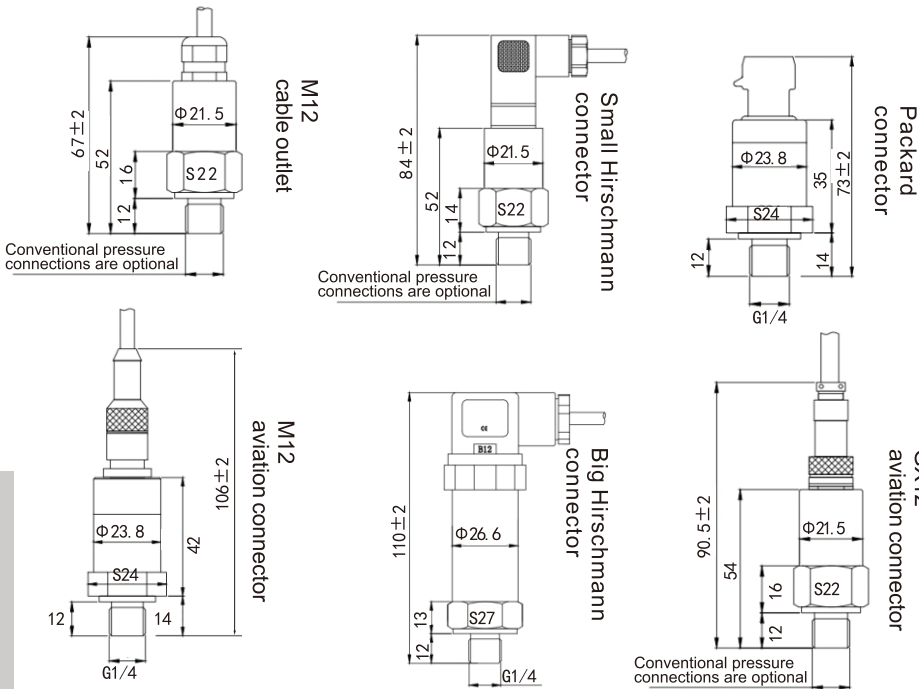

LFT2000 pressure transmitter is widely used in the measurement of fluid medium pressure in test systems such as fire protection, water treatment, water supply systems, air compressors, pneumatic devices, and factory automation. Adopt ceramic sensitive diaphragm with high overload capacity. It has excellent anticorrosion and anti-wear performance, adopts ASIC technology, MEMS technology, and digital compensation. And it has the characteristics of small size and low price. can be applied in various complex environment.

### LFT2000 Order Ref No.

LFT2000 0-16 A4 B 1.0 P G 1.0  
**A B C D E F G**

- A Measurement Range:** -100kPa~0.3MPa...6MPa ,0~0.3MPa...60MPa
- B Output Mode:** A4 = 4~20mA(2-wired)V05 =0.5~4.5V(3-wired)V0 = 0~5V(3-wired)V10 = 0~10V(3-wired)
- C Measurement Unit:** K = kPa,P = psi,B = Bar ,M = Mpa
- D Accuracy:** 0.5 = 0.5%FS 1.0 = 1.0%FS
- E Electrical Connection:** P= Packard(Packard),D = DIN43650C(Small Hirschmann),D1 = DIN43650A(Big Hirschmann)  
M = M12 (M12waterproof outlet),C3=GX12 Three core aviation connector,C4=GX12 Four core aviation connector,H=M12 Four core aviation connector
- F Pressure Connection:** G = G1/4,G2 = G1/2,N = NPT1/4,M20 = M20\*1.5,R = R1/4,U=7/16-20UNF External thread,B = BSP1/4
- G Cable Length** 1.0 = 1m,2.0 = 2m,3.0 = 3m

### Specification

General	Value
Measurement Range	-100kPa~0.3MPa...6MPa ,0~0.3MPa...60MPa
Overload Pressure	1.5 times the rated pressure( up to 80Mpa)
Burst Pressure	2 times the rated pressure( up to 90Mpa)
Accuracy	±0.5%F.S,±1.0%F.S
Stability	<0.5%F.S/year
Working Temp	-20~85°C
Storage Temp	-40~100°C
Measured Medium	Gas or liquid compatible with 1Cr18Ni9Ti, 304 stainless steel, Fluorine rubber or Nitrile rubber
Electrical Properties	2-wired <span style="float: right;">3-wired</span>
Output Signal	4~20mA <span style="float: right;">0.5~4.5V</span> <span style="float: right;">0~5V</span> <span style="float: right;">0~10V</span>
Power Supply	10~36VDC <span style="float: right;">4.75~5.25VDC</span> <span style="float: right;">10~36VDC</span> <span style="float: right;">12~36VDC</span>
Electrical Connections	Packard, DIN43650C (small Hirschmann), DIN43650A (big Hirschmann), M12 waterproof outlet, M12 aviation connector, GX12 aviation connector (three-core/four-core)
Enclosure Protection	IP67,IP65,IP54
Pressure Connection	G1/4,NPT1/4,R1/4,BSP1/4,G1/2,7/16-20UNF,M20*1.5,M10*1,M14*1.5 etc
Pressure Form	Gauge Pressure G
Certification	Safety explosion-proof type E, RoHS, EU electrical safety standard CE

# LFT2800

## Pressure Transmitter

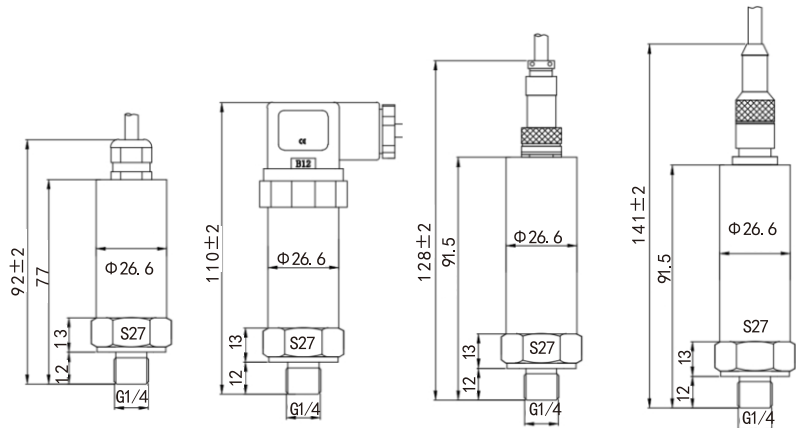

M12 cable outlet    Hirschmann connector    GX12 aviation connector    M12 aviation connector

Dimension in : mm

LFT2800 pressure transmitter is widely used in the measurement of fluid medium pressure in test systems such as fire protection, water treatment, water supply systems, air compressors, and pneumatic device and factory automation. It has excellent anti-corrosion and anti-wear performance, adopts ASIC technology, MEMS technology, digital compensation, and can be applied in various complex environment.

### LFT2800 Order Ref No.

LFT2800 0-60 A4 B 1.0 D1 G 1.0  
A    B    C    D    E    F    G

**A Measurement Range:** -100kPa...0~10kPa...60MPa

**B Output Mode:** A4 =4~20mA( 2-wired),V05=0.5~4.5V(3-wired),V0=0~5V(3-wired),V10=0~10V(3-wired),RS=RS-485(4-wired)

**C Measurement Unit:**K=kpa,P=psi,M=Mpa,B=bar

**D Accuracy :** 0.25 = 0.25%F.S,0.5 = 0.5%F.S,1.0 = 1.0%F.S

**E Electrical Connection:** D1=DIN43650A(Big Hirschmann),M=M12(M12 waterproof outlet)

C3=GX12 Three-core aviation connector,C4=GX12 Four-core aviation connector,H=M12 Four-core aviation connector

**F Pressure Connection:** G=G1/4,G2=G1/2,N=NPT1/4,M=M20\*1.5,R=R1/4,U=7/16-20UNF external screw,B=BSP1/4

**G Cable Length:** 1.0 = 1m,2.0 = 2m,3.0 = 3m

### Specification

General	Value				
Measurement Range	-100kPa...0~10kPa...60MPa				
Overload pressure	1.5 times of the rated pressure				
Accuracy	±1.0%F.S(-100kPa...0~1kPa...2kPa...60MPa)				
	±0.5%F.S(-100kPa...0~3kPa...9kPa...60MPa)				
	±0.25%F.S(-100kPa...0~10kPa...60MPa)				
Stability	<0.5%F. S/year				
Working Temp	-20~85°C				
Storage Temp	-40~100°C				
Measured Medium	Gas or liquid compatible with 304 and 316L stainless steel, Fluorine rubber or Nitrile rubber				
Electrical Properties	2-wired(current)	3-wired(voltage)			4-wired
Output Signal	4~20mA	0.5~4.5V	0~5V	0~10V	RS485
Power Supply	8~36VDC	4.75~5.25VDC	8~36VDC	12~36VDC	10~30VDC
Electrical Connection	DIN43650A (Big Hirschmann),M12 waterproof outlet,GX12 aviation connector(three-core/four-core),M12 four-core aviation connector				
Enclosure Protection	IP54、IP65				
Pressure Connection	G1/4、NPT1/4、R1/4、G1/2、7/16-20UNF、M20*1.5、M10*1、M14*1.5etc				
Pressure Form	Gauge Pressure G/Absolute Pressure A				
Certification	Safety explosion-proof type E, RoHS, EU electrical safety standard CE				

①Measured at 25°C, including the comprehensive accuracy of linearity, repeatability and hysteresis

# LFT2010

High Accuracy  
Pressure Sensor

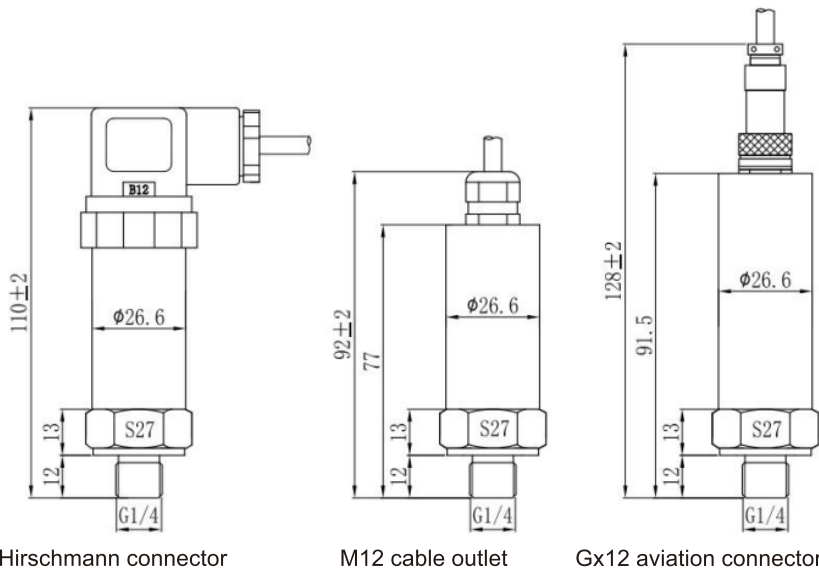

Hirschmann connector

M12 cable outlet

Gx12 aviation connector

Dimension in : mm



LFT2010 high-precision pressure transmitter adopts a high-precision oil-filled diffusion silicon core, and is automatically tested by a computer, and the zero point and temperature performance compensation in a wide temperature range is carried out by a laser resistance trimming process. This model has the features of high precision, high quality, small size and easy installation. Adopt high-performance MCU with low power consumption to collect pressure signals and convert into standard analog signal output, which is widely applied in fluid media pressure measurement in high-precision test systems such as fire protection, water treatment, water supply systems, air compressor pneumatic devices, and factory automation.

## LFT2010 Order Ref NO

LFT2010 0-30 A4 B 0.1 D1 G 1.0  
**A B C D E F G**

- A Measurement Range** 0~0.1...4MPa
- B Output Mode** A4 = 4~20mA(2-wired) V0 = 0~5V (3-wired)  
V10 = 0~10V (3-wired) RS = RS-485 (4-wired)
- C Measurement Unit** K = Kpa M = Mpa P = Psi B = Bar
- D Accuracy** 0.1= 0.1%F.S
- E Electrical Connection** D1 = DIN43650A(Big Hirschmann), M = M12(M12Waterproof outlet)  
C3=GX12 Three-core aviation connector, C4=GX12 Four-core aviation connector, H=M12 Four-core aviation connector
- F Pressure Connection** G1= G1/4 G2 = G1/2 N = NPT1/4 M3 = M20\*1.5 M1= M10\*1 M2= M12\*1
- G Cable Length** 1.0 = 1m 2.0 = 2m 3.0 = 3m

## Specification

General	Value			
Measurement Range	0~0.1...-4MPa			
Overload Pressure	1.5 times of the rated pressure			
Accuracy	±0.1%F.S			
Stability	<0.1%F.S/year			
Working Temp	-20~85°C			
Storage Temp	-40~100°C			
Measured Medium	Gas or liquid compatible with 304 and 316L stainless steel, Fluorine rubber or Nitrile rubber			
Electrical Properties	2-wired	3-wired		4-wired
Output Signal	4~20mA	0~5V <sup>①</sup>	0~10V <sup>②</sup>	Rs485
Power Supply	10~36VDC	10~36VDC	14~30VDC	10~30VDC
Electrical Connection	DIN43650A (Big Hirschmann),M12 waterproof outlet, GX12 aviation connector(three-core/four-core),M12 four-core aviation connector			
Enclosure Protection	IP65/IP67			
Pressure Connection	G1/4,NPT1/4,R1/4,G1/2,7/16-20UNF,M20*1.5,M10*1,M14*1.5etc.			
Pressure Form	Gauge Pressure G			
Certification	Safety explosion-proof type E, RoHS, EU electrical safety standard CE			

①When the accuracy is 0.1%F.S, the output is 1-5V  
②When the accuracy is 0.1%F.S, the output is 1-10V

# LFT2020

## Sanitary Flat Membrane Pressure Transmitter



LFT2020 Sanitary Flat Membrane Pressure Transmitter adopts high-performance oil-filled diffusion silicon core. The internal special-purpose integrated circuit converts the millivolt signal of the sensor into standard voltage, current or 485 signal, which can be directly connected with computer interface card, control instrument, intelligent instrument or PLC. The process connection of the pressure transmitter is sealed by sterile chuck type diaphragm, which is widely applied in the food, dairy, chemical and pharmaceutical industries.

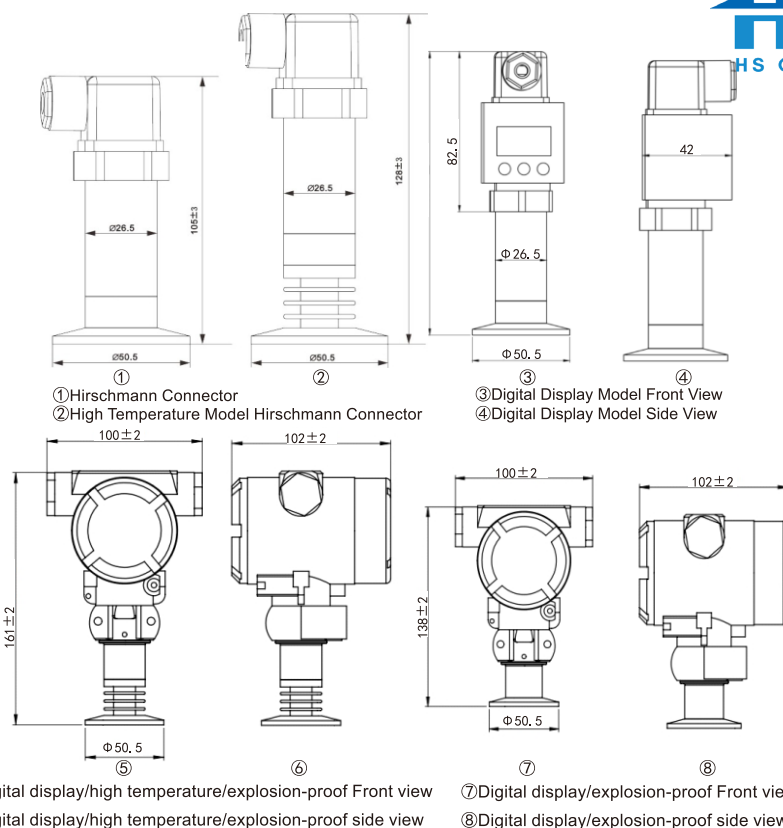

① Hirschmann Connector  
② High Temperature Model Hirschmann Connector  
③ Digital Display Model Front View  
④ Digital Display Model Side View  
⑤ Digital display/high temperature/explosion-proof Front view  
⑥ Digital display/high temperature/explosion-proof side view  
⑦ Digital display/explosion-proof Front view  
⑧ Digital display/explosion-proof side view

### LFT2020 Order Ref NO

Dimension in : mm

LFT2020 0-10 A4 B 1.0 D1 K2 N 1.0  
A B C D E F G

<b>A Measurement Range</b>	-100kPa...0~10kPa...7MPa
<b>B Output Mode</b>	A4 = 4~20mA(2-wired) V05 = 0.5~4.5V(3-wired) V0 = 0~5V(3-wired) V10 = 0~10V(3-wired) RS = RS-485 output(4-wired)
<b>C Measurement Unit</b>	K = kPa M = Mpa P = Psi B = Bar
<b>D Accuracy</b>	0.5 = 0.5%F.S 0.1 = 0.1%F.S
<b>E Electrical Connection</b>	D1 = DIN43650A(Big Hirschmann), M = M12(M12 Waterproof outlet), C3 = GX12 Three-core aviation connector C4 = GX12 Four-core aviation connector, H = M12 Four-core aviation connector, M = M20 waterproof cable outlet(Explosion-Proof digital display)
<b>F Pressure Connection</b>	K2 = 50.5mm chunk connection
<b>G Digital Display Mode</b>	N = Without display(General type), D1 = General type digital display <sup>④</sup> , D2 = Explosion-proof digital display
<b>Cable Length</b>	1.0 = 1m 2.0 = 2m <b>Note</b> ④: When the selected type is conventional digital display sanitary flat film pressure transmitter, the cable outlet is only the big Hirschmann connector, and the power supply voltage is all 12~30VDC

### Specification

General	Value			
Measurement Range	-100kPa...0~10kPa...7MPa			
Overload Pressure	1.5 times of the rated pressure			
Accuracy <sup>①</sup>	±0.5%F.S			
Stability	<0.5%F.S/year			
Working Tempe <sup>②</sup>	-20~85°C			
Mediam-Temp <sup>③</sup>	-40°C~100°C/-40°C~150°C			
Measure Medium	Media Compatible with 316L Stainless Steel, Selected Rubber Rings			
Sanitary Flat Membrane Pressure Transmitter				
Electrical Properties	2-wired	3-wired	3-wired	4-wired
Output Signal	4~20mA	0.5~4.5V	0~10V	RS485
Power Supply	10~36VDC	4.75~5.25VDC	12~36VDC	10~30VDC
Electrical Connection	DIN43650A (Big Hirschmann), M12 waterproof outlet, M12 aviation connector(four cores), GX12 aviation connector (three/four cores)			
Explosion-proof Digital Display Sanitary Flat Membrane Pressure Transmitter				
Electrical Properties	2-wired	3-wired	3-wired	4-wired
Output Signal	4~20mA	0~10V	0~10V	Rs485
Power Supply	10~30VDC	14~36VDC	14~36VDC	10~36VDC
Electrical Connection	Direct cable outlet			
Enclosure Protection	IP65			
Pressure Connection	50.5mm chunk connection			
Pressure Form	Gauge Pressure G/Absolute Pressure A			
Certification	EU electrical safety standard CE			

① Measured at 25°C, including the comprehensive accuracy of linearity, repeatability and hysteresis  
② Without heat sink is -40~100°C, with heat sink is -40~150°C ③ The oil-filled silicon core is 316L stainless steel

# LFT2030

## High Temperature Resistance Pressure Sensor



LFT2030 high temperature resistant pressure transmitter adopts high-performance pressure core, and the internal special integrated circuit converts millivolt signal of the sensor into standard voltage, current or 485 signal, which can be directly connected with computer interface card, control instrument, smart instrument or PLC, etc. Long-distance transmission can use the current output method. It has the characteristics of small size, light weight, all stainless steel sealing structure, etc. and can work in corrosive environment. The product is easy and simple to install, has very good anti-vibration and anti-shock performance, and is widely applied in process control, HVAC, medical equipment and other fields.

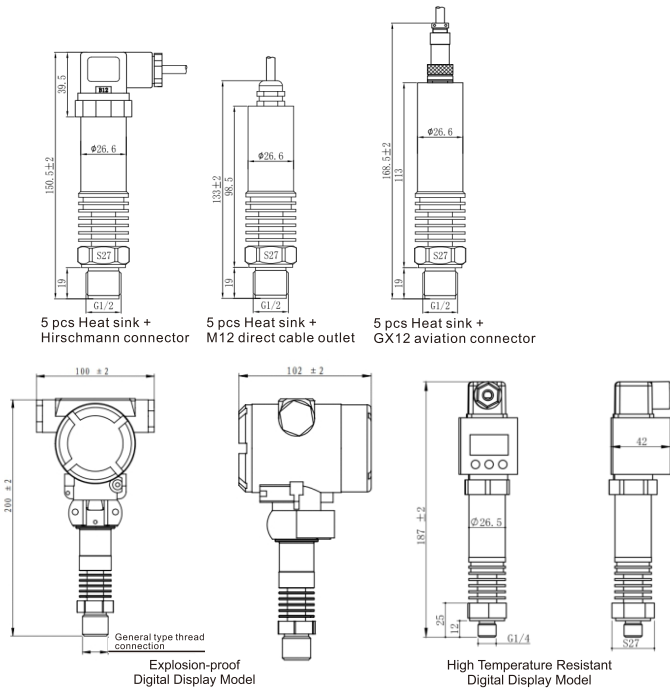

5 pcs Heat sink + Hirschmann connector

5 pcs Heat sink + M12 direct cable outlet

5 pcs Heat sink + GX12 aviation connector

Explosion-proof Digital Display Model

High Temperature Resistant Digital Display Model

### LFT2030 Series Order Ref NO

Dimension in : mm

LFT2030 0-60 A4 B 1.0 D1 G B N 1.0  
**A B C D E F G**

- A Range** -100kPa...0~10kPa...60MPa
- B Output Mode** A4=4~20mA(2-wired), V05=0.5~4.5V(3-wired), V0=0~5V(3-wired), V10=0~10V(3-wired), RS=RS-485 output(4-wired)
- C Measurement Unit** K = kPa M = Mpa P = Psi B = Bar
- D Accuracy** 0.5 = 0.5%F.S 1.0 = 1.0%F.S
- E Electrical Connection** D1 = DIN43650A(Big hirschman), M = M12(M12 waterproof outlet), C3 = GX12 Three-core aviation connector, C4 = GX12 Four-core aviation connector, H = M12 Four-core aviation connector, M20 = M20 waterproof outlet (Explosion-proof digital display)
- F Pressure Connection** G = G1/4 G2 = G1/2 N = NPT1/4
- G Corespecifications** A = Ceramic core B = Oil-filled silicon core
- Digital Display Mode** N = Without display (General type) D1 = General type digital display D2 = Explosion-proof digital display
- Cable Length** 1.0 = 1m 2.0 = 2m 3.0 = 3m

### Specification

General	Value			
Measurement Range	-100kPa...0~10kPa...60MPa(Oil-filled silicone)		-100kPa~0.3MPa...60MPa(ceramics)	
Overload Pressure	1.5 times of the rated pressure			
Accuracy	±0.5%F.S		±0.5%F.S/±1.0%F.S	
Stability	<0.5%F.S/year			
Working Temp	-20~+85°C			
Medium Temp	5 pcs heat sink: 180°C, 10 pcs heat sink: 260°C			
Measured Medium	Gas or liquid compatible with S304 and 316L Fluorine rubber or Nitrile rubber		Gas or liquid compatible with 1Cr18Ni9Ti, S304 Fluorine rubber or Nitrile rubber	
High Temperature Resistant Pressure Transmitter				
Electrical Properties	2-wired	3-wired voltage		4-wired
Output Signal	4~20mA	0.5~4.5V	0~5V	0~10V
Power Supply	10~36VDC	4.75~5.25VDC	10~36VDC	12~36VDC
Electrical Connection	DIN43650A (Big Hirschmann), M12 waterproof outlet, M12 aviation connector (three/four cores)			
Explosion-proof Digital Display High Temperature Resistant Pressure Transmitter				
Electrical Properties	2-wired	3-wired		4-wired
Output Signal	4~20mA	0~10V		RS485
Power Supply	10~30VDC	14~36VDC		10~36VDC
Electrical Connection	Direct cable outlet			
Enclosure Protection	Ip65			
Pressure Connection	G1/4, NPT1/2, G1/2			
Pressure Form	Gauge Pressure G/Absolute Pressure A			
Certification	RoHS, EU electrical safety standard CE			

# LFT2050

## Differential Pressure Sensor

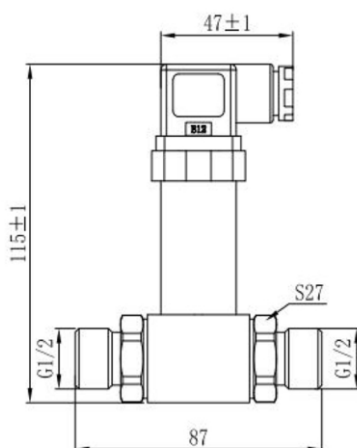

Hirschmann Connector Front View

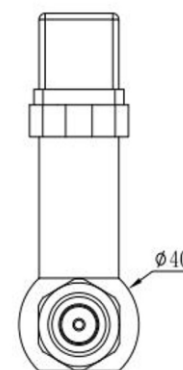

Hirschmann Connector Side View

LFT2050 Differential Pressure Sensor uses silicon piezoresistive differential pressure sensor as the core components. Through temperature compensation, digital circuit correction and signal conditioning, it then outputs standard industrial signal. It adopts stainless steel structure shell, with strong corrosion resistance. Featured with advanced design, perfect technology, excellent equipment, stability and reliability, the Transmitter is widely used in various differential pressure measurement, especially in aviation, automobile, chemical industry, medical equipment, shipping, and etc.

Dimension in : mm

### LFT2050 Order Ref NO

LFT2050 0-60 A4 B 0.25 D1 G 1.0  
**A B C D E F G**

**A Range** 0~10Kpa...3.5MPa

**B Output Signal** A4 = 4~20mA(2-wired) V10 = 0~10V(3-wired) RS= RS-485(4-wired)

**C Measurement Unit** K= kPa M = Mpa P = Psi B = Bar

**D Accuracy** 0.25 = 0.25%F.S 0.1 = 0.1%F.S

**E Electrical Connection** D1 = DIN43650A(Big Hirschmann) M = M12(M12 Waterproof outlet)

C3=GX12 Three-core aviation connector, C4=4-core aviation connector),H=M12 Four-core aviation connector

**F Pressure Connection** G = G1/4 G2 = G1/2 R = R1/4 M = M20\*1.5 N = NPT1/4

**G Cable Length** 1.0 = 1m 2.0 = 2m 3.0 = 3m

### Specification

General	Value		
Measurement Range	0~10Kpa... 3.5MPa		
Overload Pressure	1.5 times of the rated pressure		
Accuracy <sup>①</sup>	±0.25%F.S(100kPa...3.5MPa)/±0.5%F.S(0...100KPa)		
Stability	<0.5%F.S/Year		
Working Temp	-40~60°C		
Storage Temp	-40~100°C		
Measured Medium	Gas or liquid compatible with 304 and 316L stainless steel, Fluorine rubber or Nitrile rubber		
Electrical Properties	2-wired	3-wired	4-wired
Output Signal	4~20mA	0~10V	RS485
Power Supply	10~36VDC	12~36VDC	10~30VDC
Electrical Connection	DIN43650A (Big Hirschmann), M12 waterproof outlet, GX12 aviation connector(three-core/four-core), M12 four-core aviation connector		
Pressure Connection	G1/4,NPT1/4,R1/4,G1/2,7/16-20UNF,M20*1.5,M10*1,M14*1.5 etc.		
Pressure Form	D(Differential pressure)		
Enclosure Protection	Ip65		
Certification	EU electrical safety standards CE, RoHS		

①Measured at 25°C, including the comprehensive accuracy of linearity, repeatability and hysteresis.

# LFT2060

## Refrigeration Pressure Transmitter

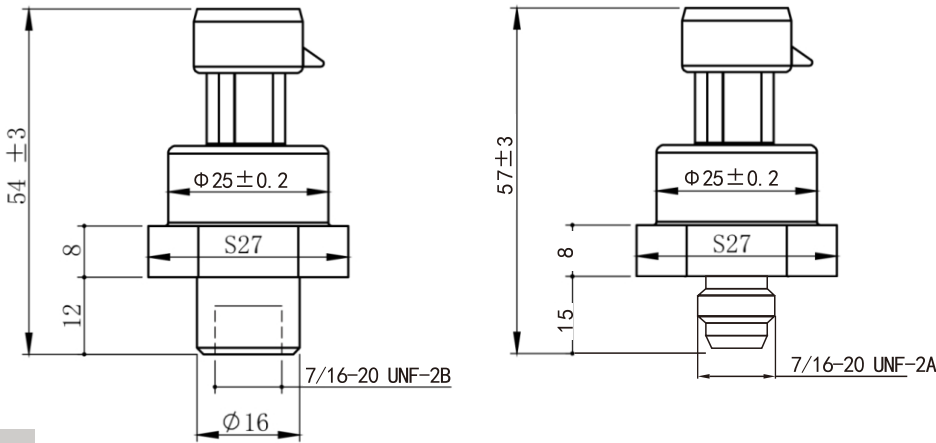

Dimension in : mm

LFT2060 pressure transmitter adopts ceramic capacitor core, which is an ideal choice for refrigerant pressure measurement occasions. The standard 0.5-4.5V output signal, has the advantages of wide operating temperature high precision, high waterproof level, and anti-condensation water. It is suitable for the pressure measurement of most common refrigerants, and also has a high burst pressure.

### LFT2060 Order Ref NO

LFT2060 0-50 V05 B 1.5 P A 1.0 T1  
**A B C D E F G**

A Range	B Output Mode	C Measurement Unit	D Accuracy	E Electrical Connection	F Pressure Connection	G Cable Length	Working Temp
0~50Bar	V05 = 0.5~4.5V(Three-wired) (Proportional voltage output)	K = kPa P = psi M = Mpa B = Bar	1.5= 1.5%FS 2.5= 2.5%FS	P = Packard(Packard)	A=7/16-20UNF External thread B=7/16-20UNF Internal thread	1.0 = 1m 2.0 = 2m	T1=-20°C~80°C T2=-40°C~120°C

### Specification

General	Value
Measurement Range	0~50Bar
Overload Pressure	2 times of the rated pressure
Burst Pressure	3 times of the rated pressure
Accuracy	±1.5%F.S (-20~80°C) ±2.5%F.S (-40~120°C)
Working Temp	-40~120°C
Refrigerant Medium <sup>①</sup>	R12,R22,R32,R134a,R404a,R407c, R410a,R502,R507
Electrical Properties	3-wired
Output Signal	0.5~4.5V(Proportional voltage output)
Power Supply	4.75~5.25VDC
Electrical Connection	Packard
Dielectric Strength	1800VAC for 1 second
Enclosure Protection	Ip67
Pressure Connection	7/16-20UNF Internal thread / 7/16-20UNF External thread
Pressure Form	Gauge Pressure G
Certification	RoHS, EU electrical safety standard CE

①Sealing rubber ring default is neoprene rubber

# LFT2600

## Refrigeration Pressure Sensor

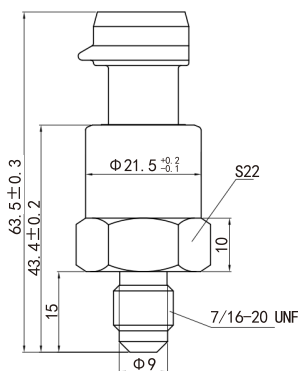

7/16-20UNF External thread

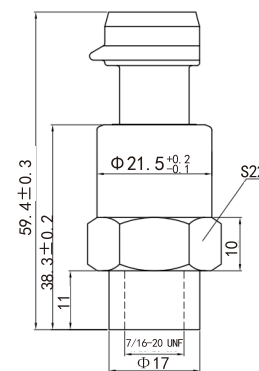

7/16-20UNF Internal thread

Dimension in : mm

LFT2600 refrigeration pressure transmitter adopts a high-performance pressure-sensing core, and with advanced circuit processing and temperature compensation technology to convert pressure changes into linear voltage signals. The product is small in size, easy to install, adopts stainless steel shell for isolation and anti-corrosion, and has a wide operating temperature range. It is suitable for measuring gas and liquid and other media that are compatible with the materials in contact with it. It is widely applied in the medium pressure measurement of air conditioning, refrigeration, cooling systems and other test systems.

### LFT2600 Order Ref NO

LFT2600 0-50 V05 B 2.0 P A 1.0  
**A B C D E F G**

A Range	B Output Mode	C Measurement Unit	D Accuracy	E Electrical Connection	F Pressure Connection	G Cable Length
0~50Bar	V05 = 0.5~4.5V(3-wired)	M= Mpa B = Bar	0.8 = 0.8%F.S 2.0 = 2.0%F.S	P = Packard	A = 7/16 External thread B = 7/16-20UNF Internal thread	1.0 = 1m

### Specification

General	Value
Measurement range	0~50Bar
Max Overload Pressure	1.5 times of measurement range
Accuracy	±2.0%F.S (-30~120°C) / ±0.8%F.S (-40~40°C)
Working Temp	-40~120°C
Storage Temp	-40~120°C
Power Supply	4.75-5.25VDC
Output	0.5~4.5VDC
Measured Medium	Gas or liquid compatible with 1Cr18Ni9Ti, 304 stainless steel and hydrogenated nitrile rubber or neoprene rubber
Pressure Connection	7/16-20UNF internal thread/7/16-20UNF external thread
Electrical Connection	Packard
Pressure Form	Gauge Pressure G
Enclosure Protection	Ip67
Certification	RoHS, EU electrical safety standard CE

# LFT2700

## Flat Film Pressure Transmitter

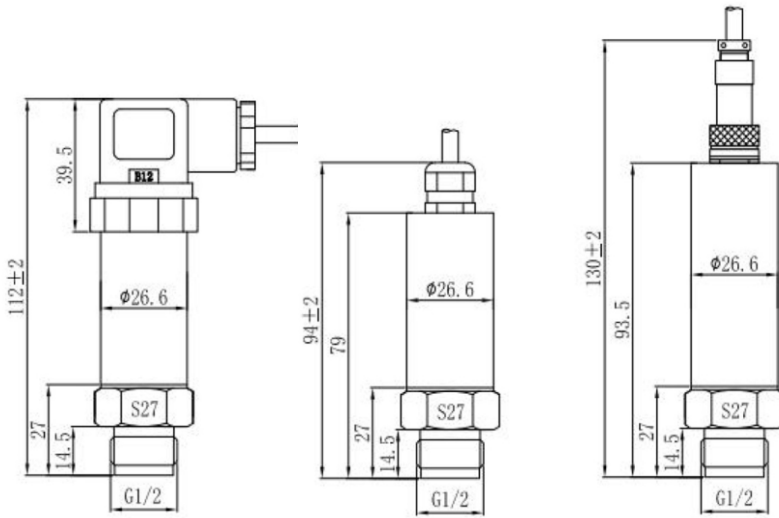

Hirschmann connector

M12 cable outlet

Gx12 aviation connector

Dimension in : mm

LFT2700 flat film pressure transmitter uses 316L flat film sensor, which has the features of anti-clogging, easy to clean, can directly measure the pressure of viscous liquid, and has excellent corrosion and wear resistance. Adopt ASIC technology, digital compensation, thread connection, easy installation and maintenance, the thread connection can choose a variety of exterior structure and a variety of electrical output mode can be chosen, gauge or absolute pressure diffusion silicon flat film thread sensor can directly measure viscous medium, such as the detection system of chemical coating paint, environmental protection, coal mine, papermaking, food processing, Polyurethane equipment, oil and others.

### LFT2700 Order Ref No.

LFT2700 **A** 0-60 **B** A4 **C** B **D** 1.0 **E** D1 **F** G **G** 1.0

**A Measurement Range:** -100kPa...0~20kPa...35MPa

**B Output Mode:** A4 = 4~20mA(2-wired), V05 = 0.5~4.5V(3-wired), V0 = 0~5V(3-wired), V10 = 0~10V(3-wired), RS = RS-485 Output(4-wired)

**C Measurement Unit:** K=kpa, P=psi, M=Mpa, B=bar

**D Accuracy :** 0.5 = 0.5%F.S, 1.0 = 1.0%F.S

**E Electrical Connection:** D1=DIN43650A(Big Hirschmann), M=M12(M12 waterproof outlet)

C3=GX12 Three-core aviation connector, C4=GX12 Four-core aviation connector, H=M12 Four-core aviation connector

**F Pressure Connection:** G= G1/2, M= M20\*1.5

**G Cable Length:** 1.0 = 1m, 2.0 = 2m, 3.0 = 3m

### Specification

General	Value				
Range	-100kPa...0~20kPa...35MPa				
Overload Pressure	1.5 times of the rated pressure				
Accuracy <sup>①</sup>	±0.5%F.S; ±1.0%F.S				
Stability	<0.5%F.S/year				
Working Temp	-20~85°C				
Storage Temp	-40~100°C				
Measured Medium	Gas or liquid compatible with 304 and 316L stainless steel. Fluorine rubber or Nitrile Rubber				
Electrical Properties	2-wired	3-wired			4-wired
Output Signal	4~20mA	0.5~4.5V	0~5V	0~10V	Rs485
Power Supply	10~36VDC	4.75~5.25VDC	10~36VDC	12~36VDC	10~30VDC
Electrical Connection	DIN43650A (Big Hirschmann), M12 waterproof outlet, M12 aviation connector (three-core/four-core)				
Enclosure Protection	IP65, IP54				
Pressure Connection	G1/2, M20*1.5				
Pressure Form	Gauge Pressure G/Absolute Pressure A				
Certification	RoHS, EU electrical safety standard CE				

① Measured at 25°C, including the comprehensive accuracy of linearity, repeatability and hysteresis.

# LFT3000

## Liquid level pressure transmitter

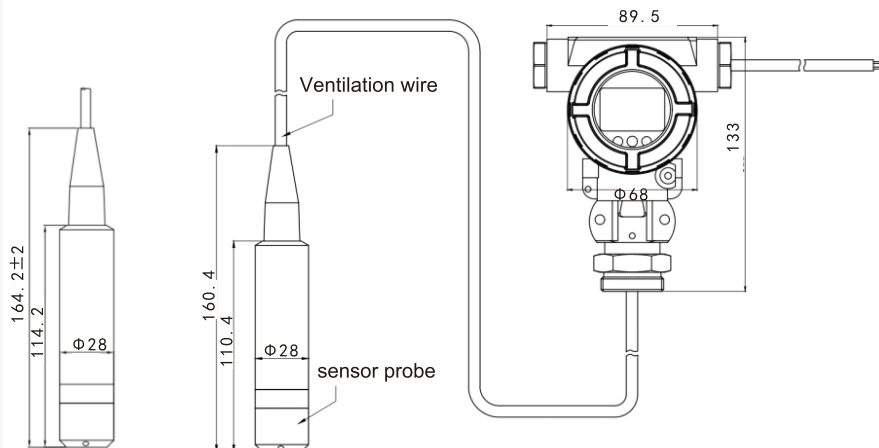

Dimension in : mm

LFT3000 liquid transmitter uses a high-performance pressure sensor as the measuring element to accurately measure the liquid level depth and convert it into a standard output signal through a special signal conditioning circuit to establish a linear correspondence between the output signal and the liquid depth, to achieve accurate measurement of liquid depth. The product has high precision, small size and convenient use. It can measure the liquid level height from the end of the transmitter to the liquid surface when it is directly put into the liquid. It is suitable for water level or liquid level measurement and control in the fields of petroleum, chemical industry, power plant, urban water supply, and hydrological exploration

### LFT3000 Order Ref No

LFT3000 0-200 A4 M 0.5 M N 1.0

A B C D E F G

A Range	B Output Mode	C Measurement Unit	D Accuracy Grade	E Electrical Connection	F Display Mode	G Cable Length
0~0.5...200mH <sub>2</sub> O	A4 = 4~20mA(2-wired) V05 = 0.5~4.5V(3-wired) V0 = 0~5V(3-wired) V10 = 0~10V(3-wired)	M=Meter CM = Centimeter	0.5 = 0.5%FS	M = Cable Outlet	N=Without display D2=Explosion-proof digital display	1.0 = 1m 2.0 = 2m
	RS =RS-485					

## Specification

General	Value
Measurement Range	0~0.5...200mH <sub>2</sub> O
Overload Pressure	1.5 times of rated pressure
Accuracy <sup>①</sup>	±0.5%F.S
Stability	<0.5%F.S/year
Working Temp	-20~85°C
Storage Temp	-40~100°C
Measured Medium	Liquid compatible with 304/316L stainless steel, PEPVC, Fluorine rubber or Nitrile rubber
Throw-in type Liquid Level Pressure Transmitter	
Electrical Performance	2-wired      3-wired Voltage      4-wired
Output Signal	4~20mA      0.5~4.5V      0~5V      0-10V      RS485
Power Supply	8~36VDC      4.75~5.25VDC      8~36VDC      12~36VDC      10~30VDC
Digital display throw-in type liquid level pressure transmitter	
Electrical Performance	2-wired      3-wired      4-wired
Output Signal	4~20mA      0-10V      RS485
Power Supply	10~30VDC      14~36VDC      10~36VDC
Electrical Connection	cable outlet
Pressure Connection	Throw-in type
Enclosure Protection	Ip68
Pressure Form	Gauge Pressure G
Certification	Safety explosion-proof type E, ROHS, EU electrical safety standards CE

① Measured at 25°C with combined accuracy of linearity, repeatability and hysteresis.

# LFT3100

## Temperature and Pressure Integrated Transmitter

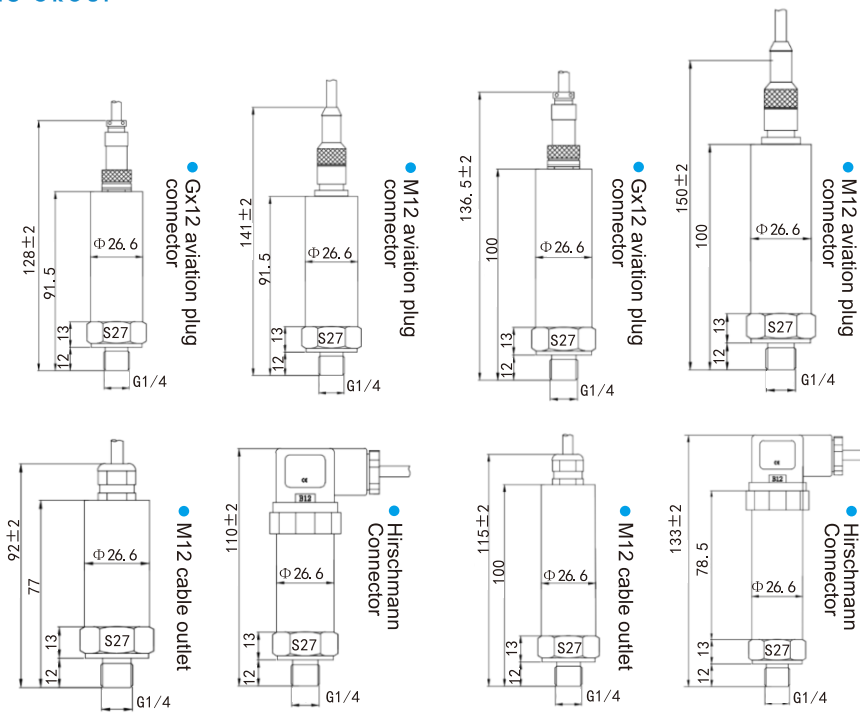

Dimension in : mm



LFT3100 temperature and pressure integrated transmitter adopts advanced piezoresistive pressure sensor and PT-100 temperature sensor, which is converted into a standard output signal through a special signal conditioning circuit. It has the advantages of advanced temperature digital compensation, wide operating temperature range and full output signals. It is suitable for the monitoring of pressure and temperature in crude food and water treatment systems.

### LFT3100 Order Ref No

LFT3100 0-100°C 0-60 M G A4 M 0.5 1.0  
**A B C D E F G**

**A Measurement Range:** Temperature Range: -20~100°C, Pressure Range: 0~10kPa...70MPa

**B Electrical Connection:** D1=DIN43650A(Big Hirschmann), M=M12(M12 waterproof outlet)

C3=GX12 Three-core aviation connector, C4=GX12 Four-core aviation connector, H=M12 Four-core aviation connector

**C Pressure Connection:** G = G1/4, G2 = G1/2, N = NPT1/4, M20 = M20\*1.5, M1 = M10\*1, M12 = M12\*1

**D Output Mode:** A4 = 4~20mA (2-wired), V05=0.5~4.5V(3-wired), RS=RS-485(4-wired)

**E Measurement Unit:** K=kpa, P=psi, M=Mpa, B=bar

**F Accuracy Grade :** 0.5 = 0.5%F.S

**G Cable Length:** 1.0 = 1m, 2.0 = 2m, 3.0 = 3m

### Specification

General	Value		
Measurement Range	0~10kPa ... 70MPa		
Temperature Range	-20~100°C(PT-100)		
Overload Pressure	1.5 times of the rated pressure		
Accuracy <sup>①</sup>	Pressure: ±0.5%F.S Temperature: ±2%FS		
Stability	<0.5%F.S/year		
Working Temp	-20~85°C		
Storage Temp	-40~100°C		
Measured Medium	Gas or Liquid Compatible with 304 or 316L Stainless Steel, Fluorine rubber or Nitrile rubber		
Electrical Performance	2-wired	3-wired	4-wired
Output Signal	4~20mA	0.5~4.5V	Rs485
Power Supply	10~30VDC	4.75~5.25VDC	10~30VDC
Electrical Connection	DIN43650A(Big hirschmann), M12waterproof outlet, GX12 aviation connector(three core / four core), M12 four core aviation connector		
Enclosure Protection	IP65, IP54		
Pressure Connection	G1/4, M12*1, M10*1, NPT1/4, G1/2, M20*1.5etc.		
Pressure Form	Gauge pressure G / Absolute pressure A		
Certification	Safety explosion-proof type E, RoHS, EU electrical safety standard CE		

① Measured at 25°C with combined accuracy of linearity, repeatability and hysteresis.

# LFT3200

## Throw-in Type Level&Temperature Pressure Transmitter

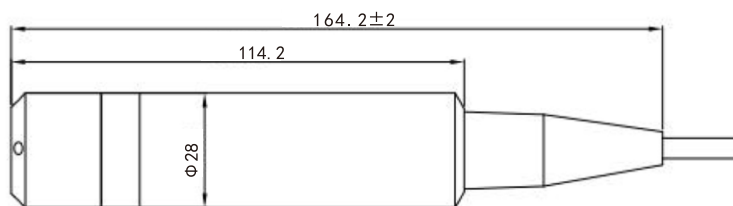

Dimension in : mm

LFT3200 temperature and liquid level integrated pressure transmitter adopts advanced piezoresistive pressure sensor and PT-100 temperature sensor, which is converted into standard output signal through special signal conditioning circuit, with advanced temperature digital compensation, wide operating temperature range, and full output signal. It is suitable for the monitoring of liquid level and temperature in crude oil, food and water treatment systems.

### LFT3200 Order Ref No

LFT3200	0-200	-20~100°C	A4	M	0.5	M	1.0
	<b>A</b>	<b>B</b>	<b>C</b>	<b>D</b>	<b>E</b>	<b>F</b>	<b>G</b>

Pressure Range <b>A</b>	Temperature Range <b>B</b>	Output Mode <b>C</b>	Measurement Unit <b>D</b>	Accuracy Grade <b>E</b>	Electrical Connection <b>F</b>	Cable Length <b>G</b>
0~1...200mH <sub>2</sub> O	-20~100°C	A4 = 4~20mA(2-wired) V05=0.5~4.5V(3-wired)	M = meter CM =centimeter	0.5 = 0.5%FS	M=cable outlet	1.0 = 1m 2.0 = 2m 3.0 = 3m
		RS =RS-485				

### Specification

General	Value		
Pressure Range	0~1...200mH <sub>2</sub> O		
Temperature range	-20~100°C,(PT-100)		
Overload Pressure	1.5 Times of rated pressure		
Accuracy	Pressure:±0.5%F.S <sup>①</sup> Temperature :±2%F.S		
Stability	<0.5%F.S/year		
Working Temp	-20~85°C		
Storage Temp	-40~100°C		
Measured Medium	Fluid compatible with 304 and 316L stainless steel, PE, PVC, Fluorine rubber or Nitrile rubber		
Electrical Performance	2-wired	3-wired voltage	4-wired
Output Signal	4~20mA	0.5~4.5V	RS485
Power Supply	10~30VDC	4.75~5.25VDC	10~30VDC
Electrical Connection	M14 waterproof cable		
Enclosure Protection	Ip68		
Pressure Connection	Throw-in Type		
Pressure Form	Gauge Pressure G		
Certification	Safety explosion-proof type E, RoHS, EU electrical safety standards CE		

①Measured at 25°C with combined accuracy of linearity, repeatability and hysteresis.

# LFT6100

## Digital Pressure Gauge

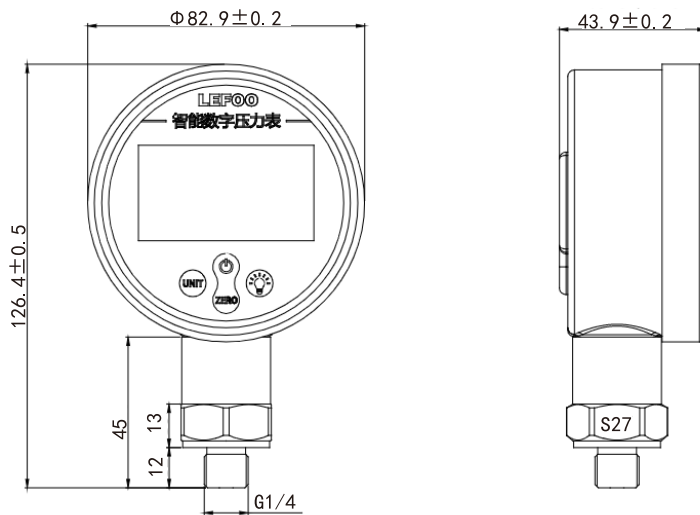

Dimension in : mm

LFT6100 digital pressure gauge adopts high-performance oil-filled diffusion silicon core, and the circuit part adopts 24-bit special AD processing chip and industrial group MCU, which has high measurement accuracy and good stability. Adopt low power consumption design, the working current is less than 2mA, and the shutdown current is less than 5uA. This product adopts high-quality 304 stainless steel shell and joints, which has good anti-shock performance. It can measure gas, water, oil and other media that are not corrosive to stainless steel. It is suitable for pressure measurement applications such as portable pressure measurement, equipment matching, and calibration equipment.

### LFT6100 Order Ref No

A Measurement Range	B Measurement Unit	C Accuracy Grade	D Pressure Connection
-100kPa...0~100kPa...60MPa	K = kpa	0.25 = $\pm 0.25\%FS$	G=G1/4
	M = Mpa	0.5 = $\pm 0.5\%FS$	M=M20*1.5
	P = psi		N=NPT1/4
	B = bar		G2=G1/2

### Specification

General	Value
Measurement Range	-100kPa...0~100kPa...60MPa
Overload Pressure	1.5 times of rated pressure
Accuracy <sup>①</sup>	$\pm 0.25\%FS$
Stability	<0.25%F.S./year
Working Temp	-20~60°C
Storage Temp	-20~60°C
Measured Medium	Gas or Liquid Compatible with 304 or 316L Stainless Steel, Fluorine rubber or nitrile rubber
Power Supply	Powered by 2 AAA batteries
Current	working current <2mA ; shutdown current <5uA
Pressure Connection	M20*1.5, G1/4, NPT1/4, G1/2 etc.
Pressure Form	Pressure Gauge G/Absolute Pressure A
Certification	EU electrical safety standards CE

① Measured at 25°C with combined accuracy of linearity, repeatability and hysteresis.

# LFT6200

## Explosion-proof Pressure Transmitter

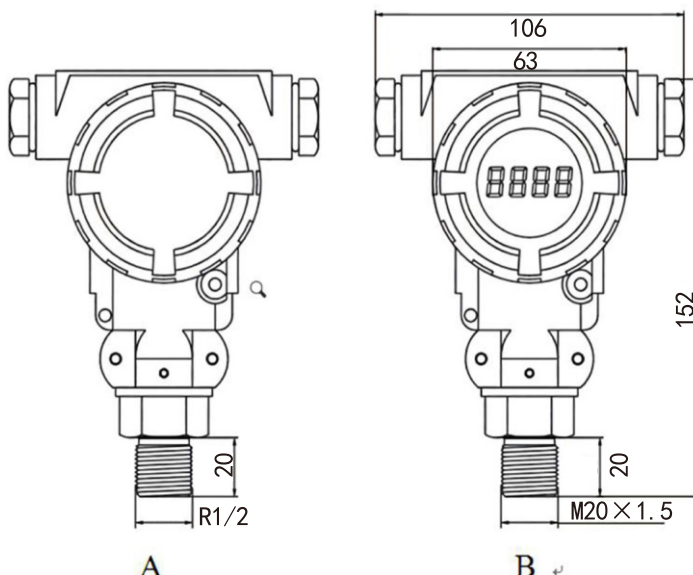

Dimension in : mm

LFT6200 pressure transmitter is an isolated explosion-proof product with high cost performance. Widely used in gas and liquid pressure detection, such as water, oil, mildly corrosive liquid and gas. The product adopts 304 stainless steel pressure head, the pressure core is selected from international famous brands, and the dedicated conversion circuit can easily calibrate its zero point and full scale. This product has the advantages of small drift, stable performance, reliable quality and reasonable structure.

### LFT6200 Order Ref No

LFT6200 0-60 A4 B 0.5 D M 1.0  
**A B C D E F G**

Measurement A Range	B Output Mode	Measurement C Unit	Accuracy D Grade	Electrical E connection	Pressure F Connection	Cable G Length
-100kPa...0~10kPa...60MPa	A4 = 4~20mA(2-wired)	K = kpa	0.25 = 0.25%F.S	D=Cable Outlet	M = M20*1.5	1.0 = 1m
	HART=4~20mA+HART(2-wired)	M = Mpa	0.5 = 0.5%F.S		G2 = G1/2	2.0 = 2m
	V10=0~10V(3-wired)	P = psi	1.0 = 1.0%F.S			3.0 = 3m
	RS =RS-485(4-wired)	B = bar				

### Specification

General	Value		
Pressure Range	-100kPa...0~10kPa...60MP		
Overload Pressure	1.5 times of rated pressure		
Accuracy <sup>①</sup>	±1.0%F.S(-100kPa...0~1kPa...2kPa...60MPa)		
	±0.5%F.S(-100kPa...0~3kPa...19kPa...60MPa)		
	±0.25%F.S(-100kPa...0~20kPa...60MPa)		
Stability	<0.5%F.S/year		
Working Temp	-20~80°C		
Storage Temp	-40~100°C		
Measured Medium	Gas or Liquid Compatible with 304 or 316L Stainless Steel, Fluorine rubber or Nitrile rubber		
Electrical Performance	2-wired	3-wired	4-wired
Output Signal	4~20mA	4~20mA+HART	0~10VDC
Power Supply	10~30VDC	14~36VDC	10~36VDC
Insulation	>100M Ω@500VDC		
Electric Strength	500VAC@60 second		
Electrical Connection	Waterproof cable outlet		
Enclosure Protection	Ip67		
Pressure Form	Gauge Pressure G/Absolute Pressure A		
Pressure Connection	M20*1.5,G1/2		

①Measured at 25°C with combined accuracy of linearity, repeatability and hysteresis

# LFT6700

## Pressure Transmitter

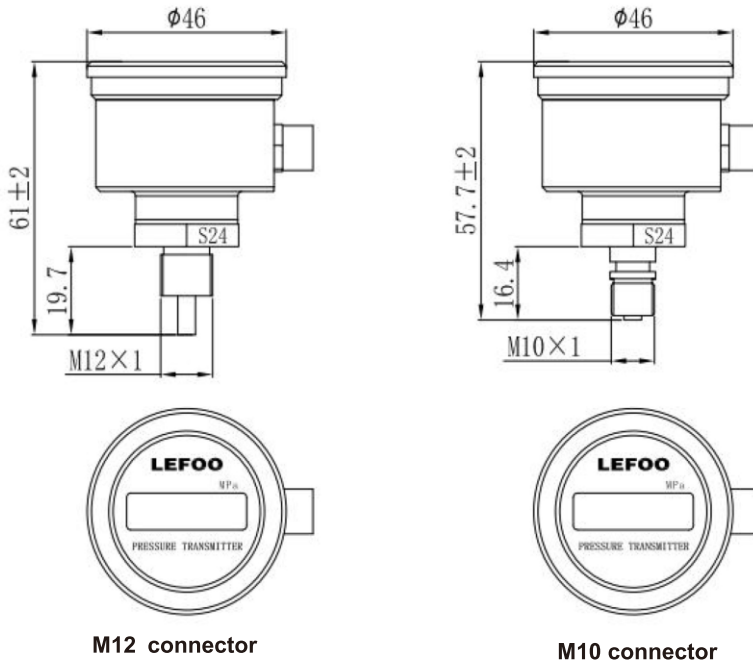

Dimension in : mm



LFT6700 is an intelligent digital pressure transmitter, suitable for real-time pressure monitoring and alarm display. Combined with the special sensor conditioning circuit, it can output the pressure signal of the standard MODBUSRTU protocol. The integrated stainless steel structure design and digital signal output have the characteristics of small size, small drift, stable performance and corrosion resistance. Suitable for pressure measurement and monitoring in fire control, petroleum, water, chemical, environmental control and other industries

### LFT6700 Order Ref No

LFT6700 0-10 M10 1.5  
**A** **B** **C**

A Measurement Range	B Pressure Connection	C Electrical Connection
0~10...60MPa	M10x1	1.5=1.5m
	M12x1 with thimble(customized)	X=Customized
	NPT1/8	

### Specification

General	Value
Measurement Range	0~10...60MPa
Overload Pressure	1.5 times of rated pressure
Burst Pressure	3.0 times of rated pressure(Max 100Mpa)
Accuracy	±1.0%F.S
Stability	<0.3%F.S/year
Working Temp	-10~60°C
Storage Temp	-20~70°C
Medium	Gas or liquid compatible with 304 stainless steel
Output Signal	RS-485
Power Supply	10~24VDC
Electrical Connection	M8 four-core straight head aviation plug
Protection Grade	IP67
Pressure Connection	M10*1,NPT1/8
Response Time	50ms
Pressure Form	Sealing Pressure S
Certification	EU electrical safety standards CE

# LFT6800

## Digital Display Pressure Transmitter

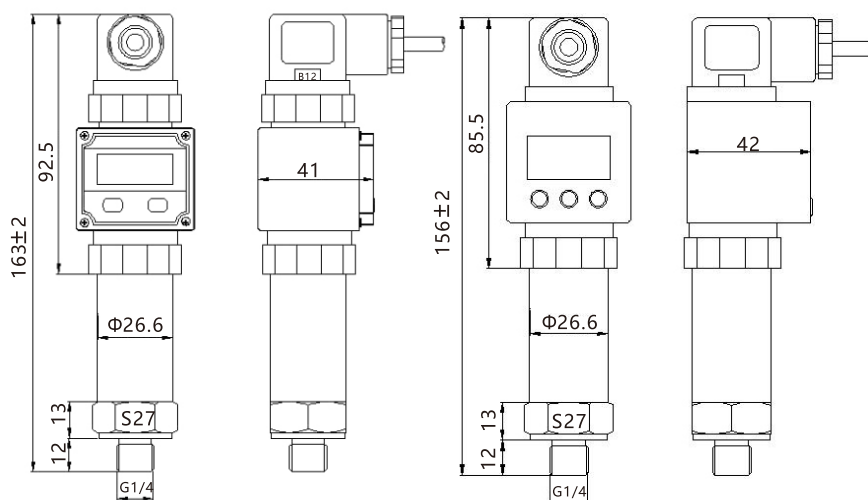

Dimension in : mm

LFT6800 digital pressure transmitter adopts high-performance ceramic core or oil-filled silicon core, with advanced processing circuit and temperature compensation technology. Convert pressure changes into linear current, voltage or RS-485 signals. The product is small in size and easy to install. It adopts a digital display head and a stainless steel shell. It is suitable for measuring media such as gas and liquid which are compatible with the material in contact with it, and can monitor and display the current measured pressure value in real time.

### LFT6800 Order Ref No

LFT6800 0-60 A4 G 1.0 D1 B A 1.0  
**A B C D E F G**

**A Measurement Range** -100kPa...0~1kPa...60MPa

**B Output Mode** A4 = 4~20mA(2-wired) V05 = 0.5~4.5V(3-wired) RS = RS-485

**C Pressure Connection** G = G1/4, G2 = G1/2, N = NPT1/4, R = R1/4, M10 = M10\*1, M20 = M20\*1.5, M12 = M12\*1

**D Accuracy Grade** 0.5 = 0.5%F.S 1.0 = 1.0%F.S

**E Electrical Connection** D1 = DIN43650A(Big Hirschmann)

**F Measurement Unit** K = kPa M = MPa P = psi B = Bar

**G Core Specification** A = Ceramic Core, B = Oil-filled silicone core

**Cable Length** 1.0 = 1m

### Specification

General	Value				
Measurement Range	-100kPa...0~1kPa...60MPa Oil-filled silicone			-100kPa~0.3MPa...60M Paceramic core	
Overload Pressure	1.5times of rated pressure			1.5times of rated pressure	
Accuracy①	±1.0%F.S; ±0.5%F.S			±1.0%F.S	
Stability	<0.5%F.S/year			<0.5%F.S/year	
Display Mode	4 digit LCD			4 digit LCD	
Working Temp	-20~75°C			-20~75°C	
Storage Temp	-30~80°C			-30~80°C	
Measured Medium	Gas and liquid compatible with SS304 and SS316L. Fluorine rubber or Nitrile rubber			Gas or liquid compatible with 1Cr18Ni9TiSS304, Fluorine rubber or Nitrile rubber	
Electrical Performance	2-wired	3-wired	4-wired	2-wired	3-wired
Output Signal	4~20mA	0~10V	Rs485	4~20mA	0~10V
Power Supply	12~30VDC	12~30VDC	12~30VDC	12~30VDC	12~30VDC
Electrical Connection	Big Hirschmann				
Enclosure Protection	Ip54				
Pressure Connection	G1/4, NPT1/4, R1/4, M12*1, M10*1, M20*1.5, G1/2 etc.				

① Measured at 25°C, including the combined accuracy of continuity, repeatability and hysteresis.

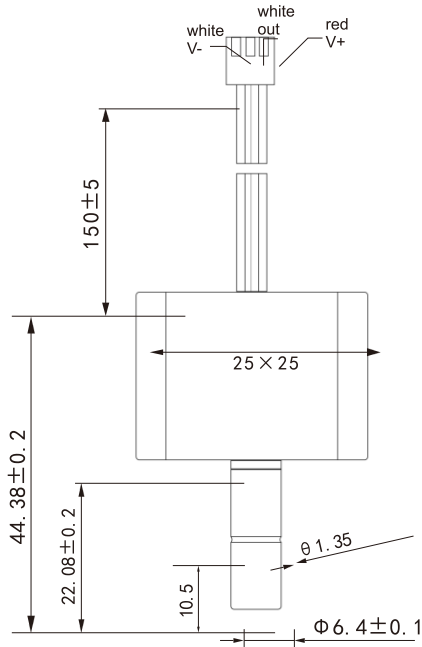

Dimension in : mm

# LFT221

## Water Pressure Transmitter



### OUTPUT CHARACTERISTIC CURVE

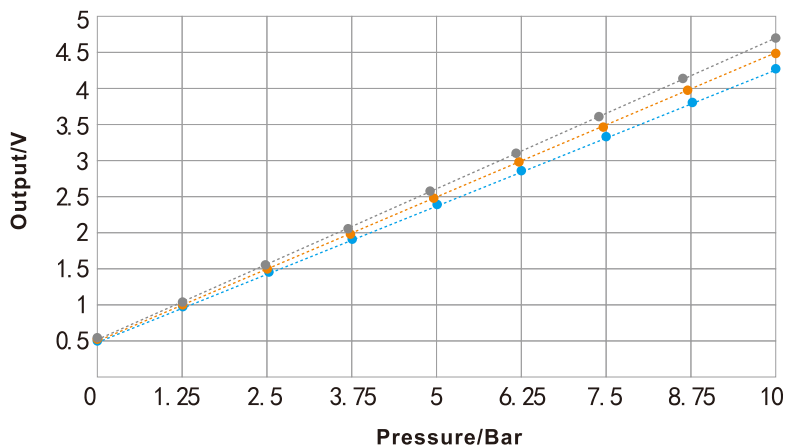

- Voltage/4.75V
- Voltage/5V
- Voltage/5.25V

- ①4.75V power supply:  $V_{out}=0.38*P+0.475$
- ②5V power supply:  $V_{out}=0.4*P+0.5$
- ③5.25V power supply:  $V_{out}=0.4*P+0.525$  Remark: P represents the current pressure, the unit is Bar

### Specification

General	Value
Measurement Range	0-1MPa(Normal pressure section)
Overload Pressure	2 times of rated pressure
Burst Pressure	3 times of rated pressure
Accuracy	±2.0%F.S
Output Mode	Voltage type(3-wired)
Power Supply	4.75~5.25VDC
Output Signal	0.5~4.5V(Proportional output)
Working Temp	0°C ~ 60°C
Storage Temp	-20°C ~ 85°C
Medium	Various fluids without corrosion to PA66, ceramics, EPDM
Load Resistance	≥14.5KΩ
Electrical Connections	3 core 2.54mm spacing Terminal
Enclosure Protection	Ip65
Pressure Connection	1/4"PE pipe quick connector

LFT221 water pressure transmitter adopts plastic shell structure, high-precision pressure core, and proportional output voltage signal. This product is mainly used in the water treatment industry and has the characteristics of small size, light weight, compact structure and good stability.

# LFDS10 Series

High-precision digital Pressure switch



LFDS101/LFDS102 Series can measure the pressure with high reliability sensor. After processing by the back-end circuit, the signal will be converted into a standard industrial electrical signal. Then it will be output and displayed. These products have plastic shell design, high contrast, double screen digital display LCD. So this series of products can be used in various industrial applications. The product with 3 key design and user friendly menu will be more convenient to use. Different connections can fully meet the specific installation requirements. Users can adjust the working parameters of built-in set items. That is very flexible and convenient. The characteristics of this series are Shock resistant, long service life, simple operation and clear display.

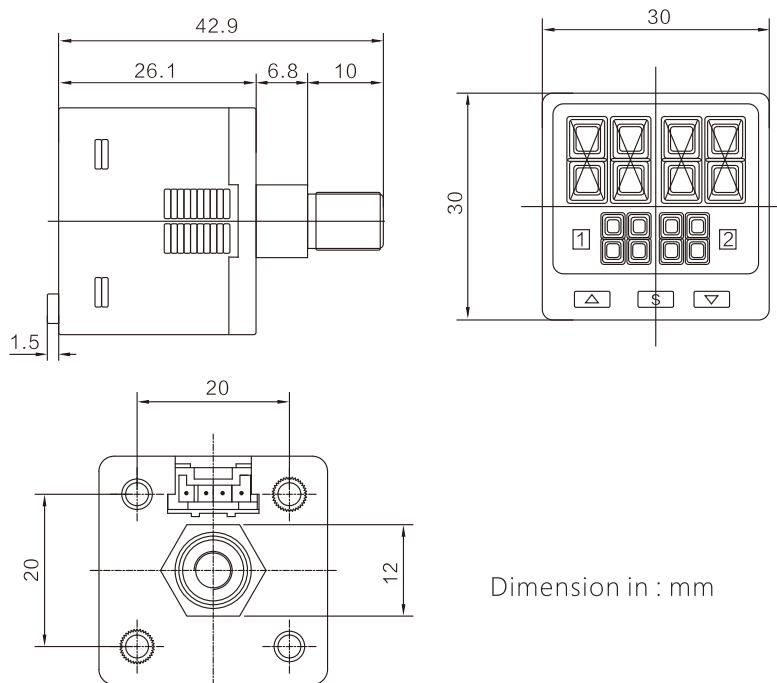

Dimension in : mm

## LFDS101(2) Order Ref NO

LFDS101-S-E-N-W

A B C D E

A Pressure Range	B Output characters (Note1)	C Connection Type	D Switching value type	E Special status (Note2)
1=High pressure type(-100~1000kPa)	S=Standard type	R=R1\8+M5 Female screw	N=NPN	W=No
2=Low pressure type(-100~100kPa)	A=Current output type	E=G1\8+ M5 Female screw	P=PNP	X=Special specification
	V=Voltage output type	M=M5 Female screw		J=Customized

Note 1:Standard type:2 switch interface(PNP or NPN);Current type:1 switch interface (PNP or NPN)+1analogue(4-20mA);Voltage type:1switch interface(PNP or NPN)+1 analogue(1-5V).  
Note 2:Any question,please contact us.

## Specification

Item\Model	LFDS102	LFDS101
Pressure Type	Standard pressure	
Pressure Range	(-100~100kPa)	(-100~1000kPa)
Proof Pressure	3 times	1.5 times
Media	Non-hazardous gas only	
Rated voltage	12~24VDC	
Current Consumption	<20mA (when no load)	
Switch output	<NPN Output type>:NPN open collector transistor,Max current:100mA,Pressure drop:<1.5V <PNP Output type>:PNP open collector transistor,Max current:100mA,Pressure drop:<1.5V	
Output Setting	NO/NC	
Hysteresis	1-8 level (Default 3 level)	
Repeatability	±0.3%F.S	
Comprehensive precision	±1%F.S	
Response Time	2.5\5\10\25\250\500\1000\5000ms	
Analog voltage output	1-5V±5% (Limit for current output type)	
Analog current output	4-20mA±5% (Limit for voltage output type)	
Storage Temperature	-10~60°C	
Operating Temperature	0~50°C	
Temperature Character	±2.5%F.S	
Enclosure	CN-14A-C2(with connector cable,2m)	

# LFDS62

## Digital Pressure Switch

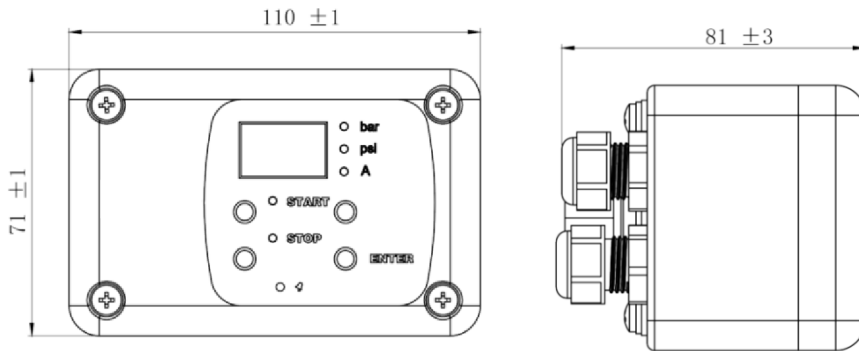

Dimension in : mm



LFDS62 Digital Pressure Controller adopts a high-reliability ceramic core for pressure measurement. The signal is processed by the back-end circuit and displayed, and the relay output is automatically controlled according to the pressure change. The product is designed with an al-engineering plastic shell. The switch pressure and rated current can be set by pressing the button. The digital tube can display the current pressure in real time and switch to display the output current. At the same time, it has the function of overcurrent protection. When used in a water pump system, the dry pumping alarm can be turned on to protect the motor. In addition, according to the actual needs of the site, the fast cycle alarm function can be turned on to avoid frequent starting and stopping of the motor. The product has the characteristics of anti-vibration, simple operation, strong stability, and clear display. Suitable for air compressors, water pumps and other pressure control systems.

### LFDS62 Order Ref No

LFDS62 1 G  
A B

**A Pressure range**

**B Pressure connection**

1=0~10Bar

G=G1/4(Default)

2=0~16Bar

N=NPT1/4

### Specification

General	Value	
Pressure range	0~10Bar	0~16Bar
Overload pressure	1.5 times rated pressure	
Accuracy	±1.0%F.S	
Operating temperature	-10°C~50°C	
Storage temperature	-20°C~60°C	
Medium	Gas or liquid compatible with 1Cr18Ni9Ti, Nylon, Fluorine rubber or Nitrile Rubber	
Output mode	AC output, the output voltage is consistent with the supply voltage	
Power supply	110~220VAC	
Protection level	Ip55	
Pressure connection	NPT1/4,G1/4 female thread	
Pressure type	Gauge pressure G	
Load capacity	10A MAX	
Display mode	3-digit digital tube	

# LFDS63

## Digital Pressure Switch

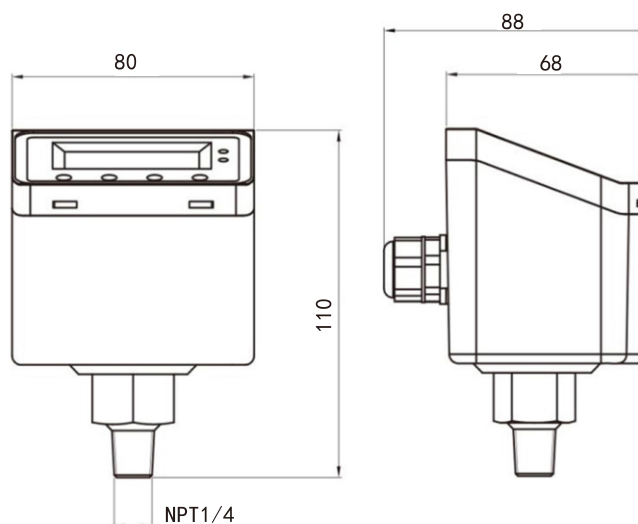

Dimension in : mm

LFDS63 Digital Pressure Switch adopts high-reliability pressure core for pressure measurement. The signal is processed by the back-end circuit and displayed, and the relay output is automatically controlled according to the pressure change. This series of products are designed with all-engineering plastic shell, and the high-contrast LCD digital display enables the product to be used in various industrial occasions. It provides a variety of connection methods to fully meet various specific installation needs, and has a variety of built-in setting items, allowing users to adjust the working parameters by themselves, which is flexible and convenient. This series of products has the characteristics of anti-vibration, long life, simple operation, strong stability and clear display.

### LFDS63 Order Ref No

LFDS63 **A** **B** **J** **R** 110V

A Pressure range	B Output mode	Special functions	Pressureconnection	Power supply
2=0~1...5MPa	N=Single AC output (active charge)	N=Routine	G=G1/4(default)	220V=AC220V
0=-101~0kPa	S=Single Switch Output	J=Customized	N=NPT1/4	110V=AC110V
			R=R1/4	

### Specification

General	Value
Pressure type	Vacuum type (negative pressure)      Medium pressure type
Pressure range	-101~0kPa      0~1.5MPa
Voltage withstand	1.5 times      2 times
Medium	Gas or liquid compatible with 1Cr18Ni9Ti, copper, Fluorine rubber or Nitrile Rubber
Display mode	LCD
Rated-operating voltage	220/110VAC
Output mode	Single AC output (active charge) Single Switch Output
Load capacity	10A MAX
Storage temperature	-40°C~85°C
Operating temperature	-10°C~50°C
Protection level	Ip54
Pressure connection	G1/4(default),NPT1/4,R1/4
Accuracy	±1%F.S
Dimensions	80*98*110mm(with connector)

# LFDS65

## Digital Pressure Switch

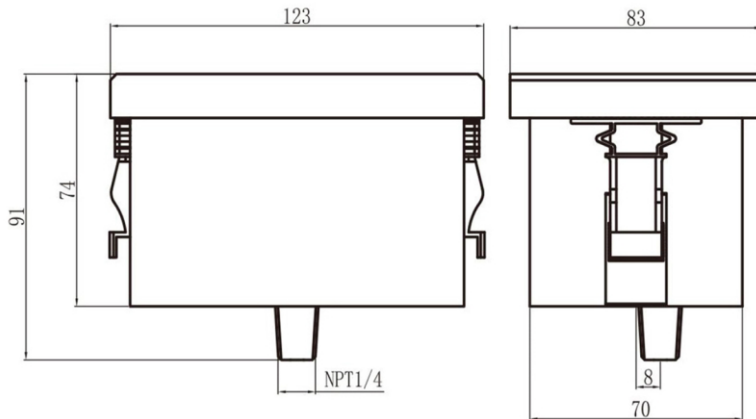

Dimension in : mm



LFDS65 (650/652) series intelligent Pressure Switch is an intelligent control instrument integrating pressure measurement, large-screen LCD display and control. The instrument can automatically open/close the relay output according to the pressure state in the container, in order to maintain the pressure in the container. A variety of connection methods are provided to fully meet various specific installation requirements. Various setting items are built in, and the working parameters can be adjusted by the user. It is flexible and convenient with simple operation, clear display, anti-vibration, high control accuracy. High, long service life and other characteristics.

### LFDS65 Order Ref No

LFDS65 2 N J R 220V  
**A B C D**

A Pressure Range	B Output type	C Special function	D Pressure connection	Power supply
2=0~2MPa	S=Single Switch Output	N=Default	N=NTP1/4(default)	220V=AC220V
0=-101~0kPa	N=Single AC output	J=Customized	G=G1/4 R=R1/4	110V=AC110V

### Specification

General	Value	
Pressure type	Vacuum type (negative pressure)	Positive pressure
Pressure range	-101~0kPa	0~2.0MPa
Voltage withstand	1.5times	2times
Medium	Non-corrosive dry gas	Gas or Liquid Compatible with 1Gr18Ni9TiCopper, Fluorine rubber or Nitrile Rubber
Display mode	LCD	
Rated operating voltage	Gauge pressure	
Measurement methods	220/110VAC	
Output mode	Relay switch output / AC output	
Load capacity	10AMAX(single loop)	
Storage temperature	-40°C~85°C	
Operating temperature	-10°C~50°C	
Protection level	IP54	
Installation interface	NPT1/4 male (default), G1/4, R1/4	
Special functions	Default, customized	
Accuracy	±1%F.S	

# LFW10

## Temperature Transmitter

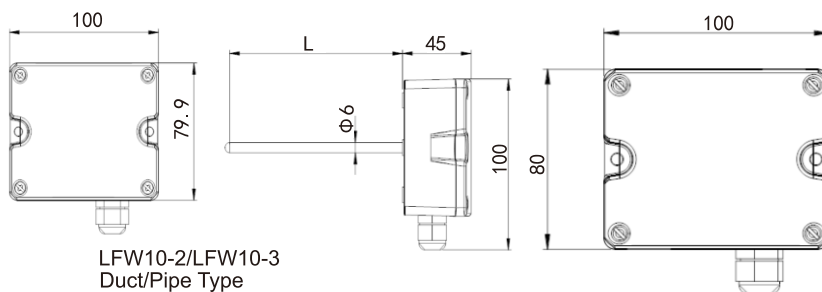

LFW10-2/LFW10-3  
Duct/Pipe Type

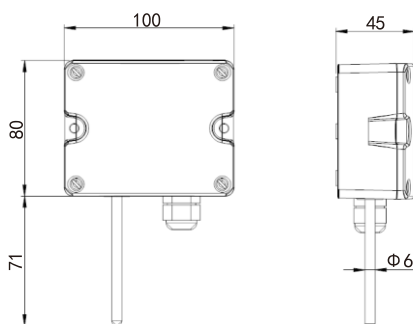

LFW10-1  
Wall Mounted Type

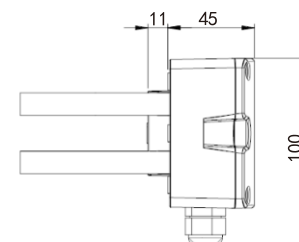

LFW10-5  
Clamp Type

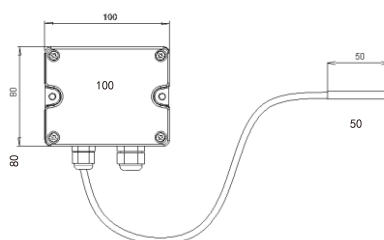

LFW10-4 Split Type

Temperature Accuracy Curve(Analog output model)

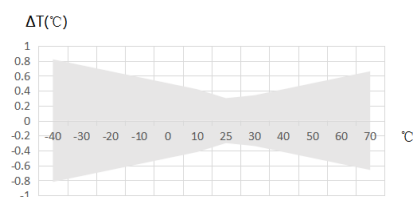

The LFW10 series temperature transmitter is a sensor specially designed for industrial applications. It is specially designed for lightning surge, electrostatic discharge, group pulse, pressure resistance, etc., and has strong anti-interference ability. There are five installation methods: wall mounted, airpipe/water pipe, split, and clamp. Three output modes of current, voltage, and thermal resistance are optional. Strong on-site trial installation capability. Spring screws and terminal posts are designed for quick installation. It can be widely used in computer rooms, HVAC, buildings, storage and other places where temperature measurement and control are required.

Dimension in : mm

### LFW10 Order Ref No

LFW10-2 - 2 1 2  
A B C

Model	A Humidity range	B Temperature range	C Probe length(LFW102/103)
LFW10-1=Wall Mounted Temperature Transmitter	V0=0~10VDC(3-wire)	0=NO	0=65MM
LFW10-2=Duct Type Temperature Transmitter	A4=4~20mA(2-wire)	1=0~50°C	1=100MM
LFW10-3=Water Pipe Type Temperature Transmitter	V5=0~5VDC(3-wire)	2=-20~60°C	2=200MM
LFW10-4=Split Type Temperature Transmitter	0=PT1000, ±0.2°C@0°C	8=Others (Customer specified)	3=150MM
LFW10-5=Clamp Type Temperature Transmitter	1=PT100, ±0.2°C @0°C		8=Others (Customer specified)
	2=NTC20K, ±0.3°C@25°C		
	3=NTC10K, ±0.3°C@25°C		

### Specification

General	Value
Sensor	High-precision thermal resistance, see selection table (resistance output type)/PT1000, Class A (analog output type)
Output	For resistance value, see Order Reference No. and Thermal Resistance Indexing Table/4-20mA or 0~10VDC, 0-5VDC
Thermal Resistance	See selection table and thermal resistance indexing table
Accuracy	Typical 0.2~0.5°C@0/25°C, see Order Reference No. ±0.3°C@25°C, see Temperature Accuracy Curve for details
Power Supply	Voltage type 15~35VDC/24VAC±20%   Current type 18.5~35VDC (RL=500Ω) 8.5~35VDC (RL=0Ω)
Output Load	(Analog output type) ≤500Ω (Current type), ≥2KΩ(0~5V), ≥3KΩ(0~10V)
Housing Material	PC housing, stainless steel probe (6mm) and casing
Working Temperature	-40~70°C, 0~95%RH(Non-condensing)
Protection Grade	Ip65

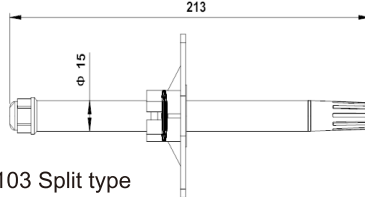
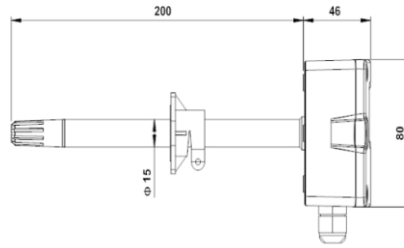
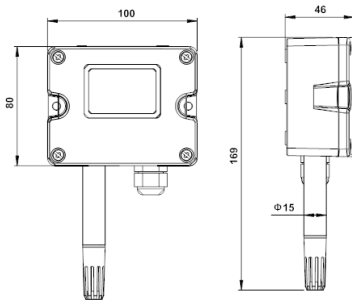
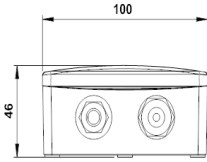
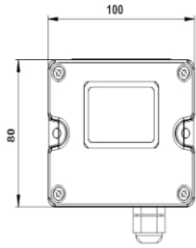

Temperature & accuracy curve

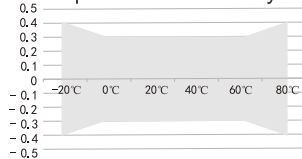

Dimension in : mm

# LFH10

## Temperature and Humidity Transmitter



LFH10 Temperature and Humidity Transmitter is specially designed for industrial applications. There are three installation methods: wall-mount, duct type, and split type. Three output models of current, voltage, and RS485 are optional, with flexible site installation adaptability. The terminal design is suitable for quick installation. It can be widely used in data room, HVAC, buildings, warehouses and other places need to measure temperature and humidity.

LFH101 Wall-mounted type

### LFH10 Order Ref No

LFH101 - 2 A4 A4 1 1  
**A B C D E**

Model	A Accuracy range	B Humidity output	C Temperature output	D Temperature range	E Display mode
LFH101-Wall-mounted temperature and humidity transmitter	3=±3%RH(0.3°C)	V10=0~10VDC(3-wire)	V10=0~10VDC(3-wire)	0=NO	0=NO
LFH102-Duct type temperature and humidity transmitter		A4=4~20mA(2-wire)	A4=4~20mA(2-wire)	1=0~50°C	1=LCD display
LFH103-Split type temperature and humidity transmitter		RS=RS485/Modbus	RS=RS485/Modbus	2=-20~60°C	
			0=PT100,±0.2°C@0°C	8=Others (customer specified)	
			1=PT100,±0.2°C@0°C		
			2=NTC20K,±0.4°C@25°C		
			6=NTC10K,±0.4°C@25°C		

### Specification

<b>1 Relative Humidity</b>	
Sensor	Digital type
Measuring Range	0%~100%RH
Output	RS485/Modbus, 0~10VDC, 4~20mA optional
Accuracy	±3%@ 20%RH & 20~80%RH
Response time	≤10s(20°C, Slow flow air)
<b>2 Temperature</b>	
Transducer	Digital type or thermal resistance, see Order Ref No.
Measuring Range	0~50°C, -20~60°C, etc.
Output	4~20mA, 0~10VDC, RS485/Modbus optional
Thermal Resistance	See Order Ref No. and Thermal Resistance Indexing Table
Accuracy	Digital type: ±0.3°C@0~60°C Thermal resistance: typical ±0.2~0.4°C@25°C, see Order Ref No.
Power Supply	Voltage type/485 type: 15~35VDC/24VAC±20%   Current type: 19.5~35VDC (RL=500Ω) / 9.5~35VDC (RL=0Ω)
Output Load	≤500Ω (Current type), ≥2KΩ (voltage type)
Display	LCD display optional, with unit display and backlight (4~20mA without backlight)
Shell Material	ABS housing, PC probe and polymer filter (stainless steel probe and sintered/stainless steel wiremesh filter optional)
Working Environment	-20~60°C, 5%-95%RH (Non-condensing)
Protection Grade	Ip65

# LFH10A

## Temperature and Humidity Transmitter

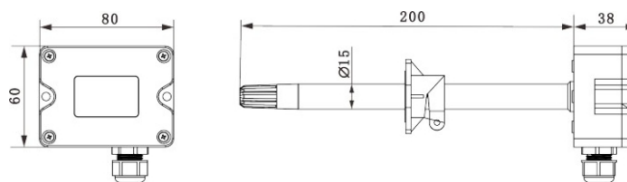

LFH10A2 Duct type

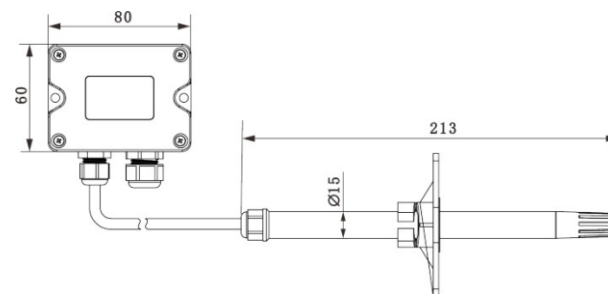

LFH10A3 Split type

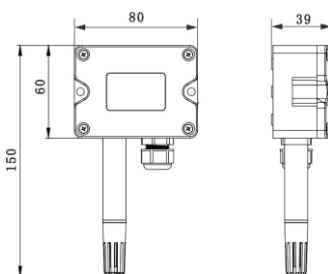

LFH10A1 Wall-mounted type

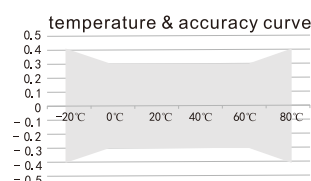

LFH10A series Temperature and Humidity Transmitter is a transmitter specially designed for industrial applications it has three installation methods: wall-mounted, duct type, and split. The three output modes of current, voltage and RS485 are optional. The on-site adaptability is strong, and the terminal design is suitable for rapid installation, it can be widely used in computer rooms, HVAC, buildings, warehousing and other places where temperature and humidity measurement is required.

### LFH10A Order Ref No

Dimension in : mm

LFH10A1 - 3 A4 A4 1 1  
A B C D E

Model	A Accuracy	B Humidity Output	C Temperature Output	D Temperature Range	E Display
LFH10A1-Wall-mounted temperature and humidity transmitter	3= $\pm 3\%RH(0.3^{\circ}C)$	V10=0~10VDC(3-wire)	V10=0~10VDC(3-wire)	0=None	0=None
LFH10A2-Duct type temperature and humidity transmitter		A4=4~20mA(2-wire)	A4=4~20mA(2-wire)	1=0~50°C	1=LCD display
LFH10A3-Split type temperature and humidity transmitter		RS=RS485/Modbus	RS=RS485/Modbus	2=-20~60°C	
			0=PT1000, $\pm 0.2^{\circ}C @ 0^{\circ}C$	8=Other (customer specified)	
			1=PT100, $\pm 0.2^{\circ}C @ 0^{\circ}C$		
			2=NTC20K, $\pm 0.4^{\circ}C @ 25^{\circ}C$		
			6=NTC10K, $\pm 0.4^{\circ}C @ 25^{\circ}C$		

## Specification

1 Relative humidity	
Sensor	Digital type
Measuring Range	0%~100%RH
Output	Output:RS485/Modbus,0~10VDC,4-20mA optional
Accuracy	$\pm 3\% @ 20^{\circ}C$ & 20~80%RH
Response time	$\leq 10s(20^{\circ}C, \text{slow flow air})$
2 Temperature	
sensor	Digital type or thermal resistance , see Order Ref No
Measuring Range	0~50°C, -20~60°C etc
Output	4~20mA, 0~10VDC, RS485/Modbus Optional
Thermal Resistance	See Order Ref No. and Thermal Resistance Indexing Table
Accuracy	Digital type: $\pm 0.3^{\circ}C @ 0\sim 60^{\circ}C$ Thermal resistance : typical $\pm 0.2\sim 0.4^{\circ}C @ 25^{\circ}C$ , see Order Ref No.
Power Supply	Voltage type/485 type: 15~35VDC/24VAC $\pm 20\%$   Current type: 19.5~35VDC(RL=500Ω)/9.5~35VDC(RL=0Ω)
Output Load	$\leq 250\Omega$ (Current type), $\geq 2K\Omega$ (Voltage type)
Display	LCD display optional, with unit display and backlight (4-20mA without backlight)
Shell Material	ABS housing, PC probe and high polymer filter
Working Environment	-20~60°C, 5%~95%RH(Non-condensing)
Protection Grade	Ip65

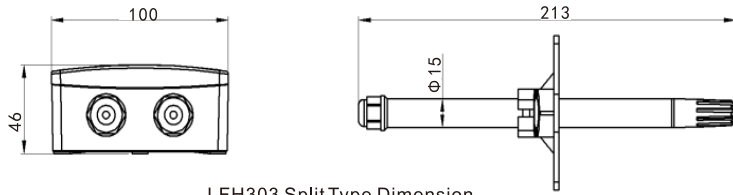

LFH303 Split Type Dimension

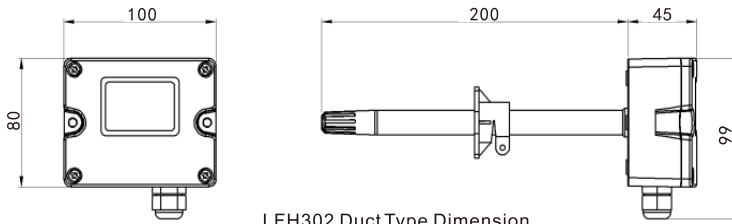

LFH302 Duct Type Dimension

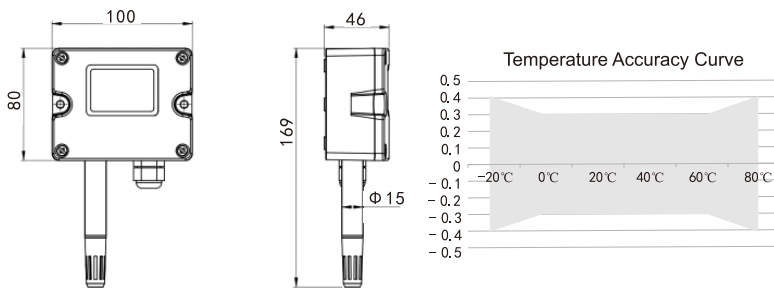

LFH301 Wall-mounted type dimension

# LFH30

## Temperature and Humidity Transmitter

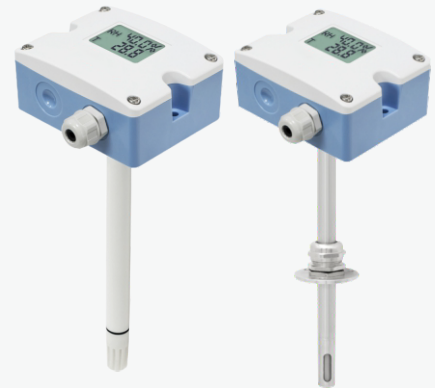

LFH30 sensitive components use imported polymer film humidity sensitive capacitors and PT1000 temperature sensitive resistors. The special breathable coating and SMD injection molding process can ensure the long stability of the probe in the environment of dust, salt spray pollution and high humidity condensation. It is calibrated with mature humidity and temperature measurement technology to ensure the accuracy. It is suitable for high-standard intelligent buildings, incubators, industrial dehumidifiers and other fields.

Dimension in : mm

### LFH30 Order Ref No

LFH30 - 2 A4 A4 1 1

**A B C D E**

Model	A Accuracy range	B Humidity output	C Temperature output	D Temperature range	E Display mode
LFH301-Wall-mounted type temperature and humidity transmitter	2= $\pm 2\%RH(0.3^\circ C)$	V10=0~10VDC(3-wire)	V10=0~10VDC(3-wire)	0=NO	0=NO
LFH302-Duct type temperature and humidity transmitter	A4=4~20mA(2-wire)	A4=4~20mA(2-wire)	A4=4~20mA(2-wire)	1=0~50°C	1=LCD display
LFH303-Split type temperature and humidity transmitter	RS=RS485/Modbus	RS=RS485/Modbus	RS=RS485/Modbus	2=-20~60°C	
			0=PT1000, $\pm 0.2^\circ C @ 0^\circ C$	8=Others (customer specified)	
			1=PT100, $\pm 0.2^\circ C @ 0^\circ C$		
			2=NTC20K, $\pm 0.4^\circ C @ 25^\circ C$		
			6=NTC10K, $\pm 0.4^\circ C @ 25^\circ C$		

### Specification

<b>1 Relative Humidity</b>		
Sensor	Humidity Sensitive Capacitor	
Measuring Range	0%~100%RH	
Output	RS485/Modbus, 0~10VDC, 4~20mA	
Accuracy	$\pm 2\% @ 20\% \& 20\% \sim 80\% RH$	
Response time	$\leq 10s(20^\circ C, \text{Slow flow air})$	
<b>2 Temperature</b>		
Sensor	Pt1000 or passive thermal resistance, see Order Ref No	
Measuring Range	0~50°C, -20~60°C, etc.	
Output	4~20mA, 0~10VDC, RS485/Modbus optional	
Thermal Resistance	See Order Ref No. and Thermal Resistance Indexing Table	
Accuracy	Digital type: $\pm 0.3^\circ C @ 5\% \sim 60\% C$ Thermal resistance: typical $\pm 0.2 \sim 0.4^\circ C @ 25^\circ C$ , see Order Ref No.	
Power Supply	Rs485 type 9~35VDC/24VAC $\pm 20\%$	Voltage type: 12~35VDC/24VDC $\pm 20\%$ Current type: 19.5~35VDC(RL=500Ω) 9.5~35VDC(RL=0Ω)
Output Load	$\leq 500\Omega$ (Current type), $\geq 2K\Omega$ (voltage type)	
Display	LCD display optional, with unit display and backlight (4~20mA without backlight)	
Shell Material	PC housing, PC probe and polymer filter (optional stainless steel probe rod, sintered/stainless steel wire mesh filter)	
Working Environment	-20~60°C, 5%~95%RH (Non-condensing)	
Protection Grade	Ip65	
Electromagnetic compatibility	EN61326-1	

# LFH51

## Probe Type Temperature and Humidity Transmitter

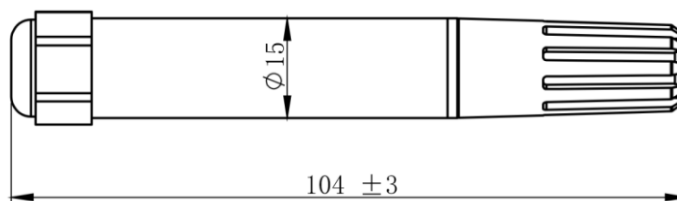

Dimension in : mm

### WIRING INSTRUCTIONS

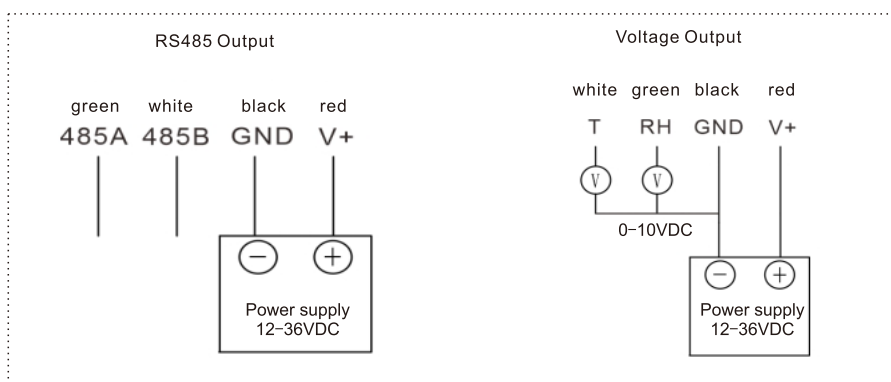

LFH51 Temperature and Humidity Transmitter adopts high-precision digital probe, which has good long-term stability and anti-interference ability, small size, simple installation and easy operation. There are two output modes of voltage and RS485 to choose from. It is widely used in ventilation ducts, industrial workshops, warehouses and other places that need to measure temperature and humidity.

### LFH51 Order Ref No

LFH51 - 3 V10 V10 2  
**A B C D**

<b>A Accuracy Range</b>	<b>B Humidity output</b>	<b>C Temperature Output</b>	<b>D Temperature Range</b>
3=±3%RH(0.3°C)	V10=0~10VDC(3-wire)	V10=0~10VDC(3-wire)	0=NO
	RS=RS485/Modbus	RS=RS485/Modbus	1=0~50°C
			2=-20~60°C
			8=Others (customer specified)

### Specification

General	Value
<b>1 Relative humidity</b>	
Sensor	Digital
Measurement Range	0%~100%RH
Output	RS485/Modbus,0~10VDC
Accuracy	±3%@ 20°C & 60%RH
<b>2 Temperature</b>	
Sensor	Digital
Output	RS485/Modbus,0~10VDC
Accuracy	±0.3°C@20°Csee the Table below
Power Supply	12~36VDC
Shell Material	PC shell
Working Environment	-40~85°C,5%-95%RH(Non-condensing)
Protection Level	Ip65

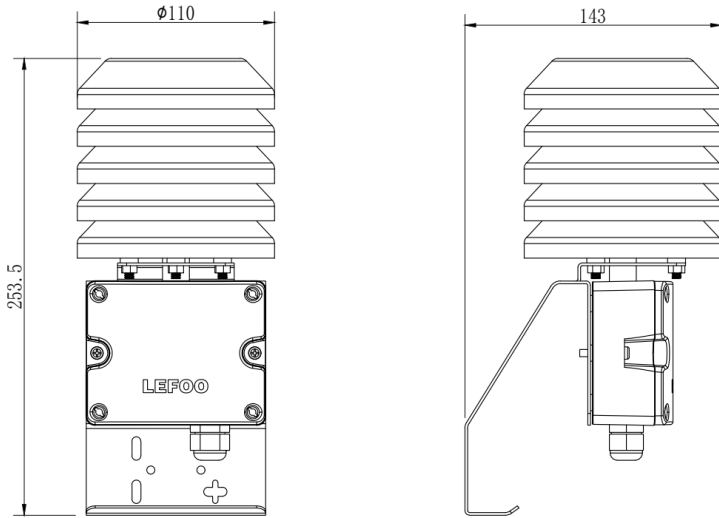

# LFH52

## Outdoor Temperature and Humidity Transmitter



LFH52 Temperature and Humidity Transmitter is a Transmitter specially designed for outdoor temperature and humidity detection. The standard radiation shield can prevent wind and rain, and provide the best protection for the transmitter in bad weather. There are three output modes of current, voltage and RS485 to choose. Can be widely used in construction site environment, weather monitoring and other outdoor occasions.

### LFH52 Order Ref No Dimension in : mm

LFH52 - 3 A4 A4 2

A B C D

A Accuracy Range	B Humidity Output	C Temperature Output	D Temperature range
3= $\pm 3\%RH(0.5^{\circ}C)$	V10=0~10VDC(3-wire) A4=4~20mA(2-wire) RS=RS485/Modbus	V10=0~10VDC(3-wire) A4=4~20mA(2-wire) RS=RS485/Modbus	0=NO 1=0~50°C 2=-20~60°C 8=Others (customerized)
		0=PT1000, $\pm 0.2^{\circ}C@0^{\circ}C$ 1=PT100, $\pm 0.2^{\circ}C@0^{\circ}C$ 2=NTC20K, $\pm 0.4^{\circ}C@25^{\circ}C$ 6=NTC10K, $\pm 0.4^{\circ}C@25^{\circ}C$	

### Specification

General	Value	
<b>1 Relative humidity</b>		
sensor	Digital	
range	0%~100%RH	
Output	RS485/Modbus,0~10VDC,4~20mA	
Accuracy	3%@ 20°C & 20~80%RH	
Response time	$\leq 10s(20^{\circ}C,slow\ air\ flow)$	
<b>2 Temperature</b>		
Sensor	Digital or thermal resistance, see Order Ref No	
Range	0~50°C,-20~60°C etc	
Output	4~20mA,0~10VDC,RS485/Modbus	
Thermal Resistance	See Order Ref No. and Thermal Resistance Indexing Table	
Accuracy	Digital type: $\pm 0.5^{\circ}C@20^{\circ}C$ Thermal resistance type: typical: $\pm 0.2\sim 0.4^{\circ}C@25^{\circ}C$ ,see Order Ref No.	
Power Supply	Voltage type/485 type: 15-35VDC24VAC+20% (isolated power supply is required for AC power supply)	Current type:18.5-35VDC(RL=500Ω)8.5-35VDC(RL=0Ω)
Output Load	$\leq 500\Omega$ (Current type), $\geq 2k\Omega$ (Voltage type)	
Display	LCD display optional, with unit display and backlight (4-20mA without backlight)	
Shell Material	PC housing, PC probe and ABS protection cover	
Working Environment	-20~60°C,5%-95%RH(Non-condensing)	
Protection Level	Ip65	

# LFH20

## Indoor Temperature and Humidity Transmitter

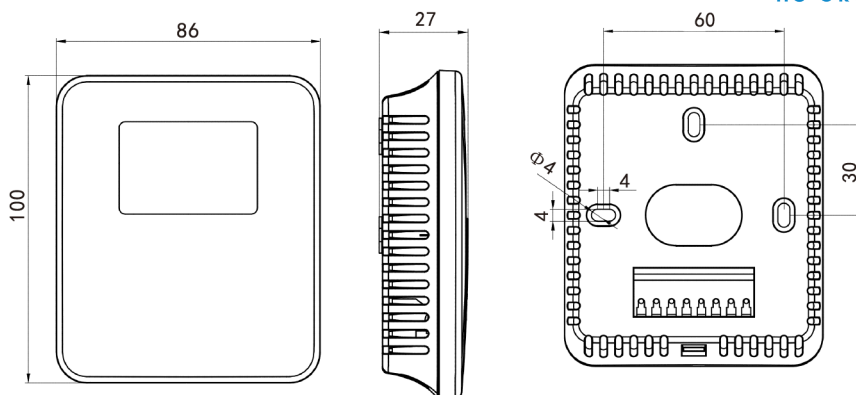

Dimension in : mm

LFH20 Temperature and Humidity Transmitter is specially designed for indoor temperature and humidity detection. It is small in size, simple in installation and easy to operate. It has special design for lightning surge, static electricity, group pulse, withstand voltage, etc, and has strong anti-interference ability. There are three output modes of current, voltage and RS485 to choose from. It can be widely used in computer rooms, buildings, warehouses and other places, where temperature and humidity are to be measured.

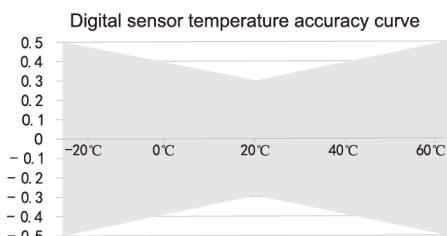

### LFH20 Order Ref No

LFH20 - 3 A4 A4 1 1

A Accuracy Range	B Humidity Output	C Temperature Output	D Temperature range	E Display
3=±3%RH(0.3°C)	V10=0~10VDC(3-wire) A4=4~20mA(2-wire)	V10=0~10VDC(3-wire) A4=4~20mA(2-wire)	0=NO 1=0~50°C	0=No display 1=LCD display
	RS=RS485/Modbus N=No output	RS=RS485/Modbus 0=PT1000,±0.2 °C@0 °C 1=PT100,±0.2 °C@0 °C 2=NTC20K,±0.4 °C @25 °C 3=NTC10K,±0.4 °C@25°C N=No output	2=-20~60°C 8=Others (customerized)	

### Specification

General	Value	
<b>1 Relative humidity</b>		
Transducer	Digital	
range	0%~100%	
Output	RS485/Modbus,0~10VDC,4~20mA optional	
Accuracy	±3%@ 20°C& 20~80%RH	
Response Time	≤10s(20°C,slow flow air)	
<b>2 Temperature</b>		
Transducer	Digital or thermal resistance,see Order Ref No	
Range	0~50°C,-20~60°Cetc	
Output	4~20mA,0~10VDC,RS485/Modbus optional	
Thermal Resistance	See Order Ref No. and Thermal Resistance Index Table	
Accuracy	Digital type:±0.3°C@20°C Thermal resistance type: typical ±0.2~0.4°C@25°C,see Order Ref No.	
Power Supply	Voltage type/485 type: 15-35VDC24VAC+20% (isolated power supply is required for AC power supply)	Current type:19.5-35VDC(RL=500Ω)9.5-35VDC(RL=0Ω)
Output Load	≤500Ω(Current type), ≥2KΩ(Voltage)	
Display	LCD display optional, with unit display and backlight	
Shell Material	PC housing	
Work Environment	-20~60°C,5%-95%RH(Non-condensing)	
Protection Grade	Ip30	
Electromagnetic Compatibility	EN61326-1	

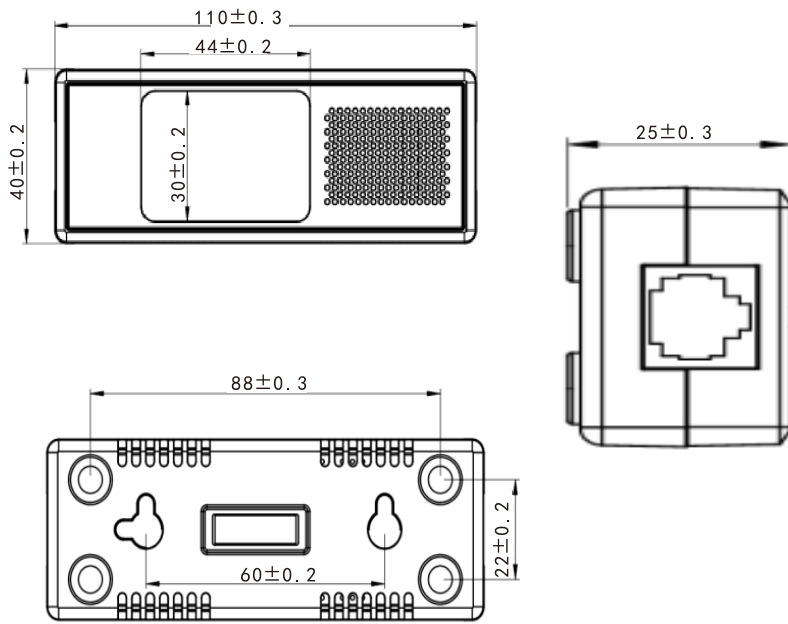

Dimension in : mm

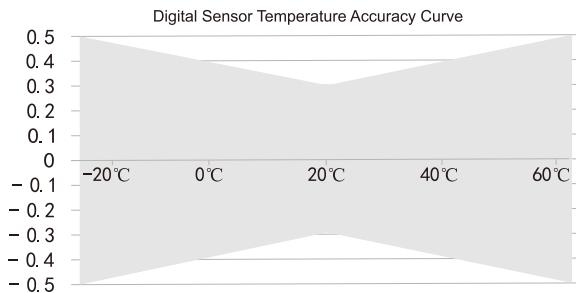

# LFH60

## Magnetic Temperature and Humidity Transmitter



LFH60 Temperature and Humidity Transmitter adopts high-precision sensor, built-in temperature and humidity sensor, high precision, fast response speed, and good long-term stability. There are four powerful magnets on the back, which can be directly attached to the cabinet or wall-mounted, which greatly improves the installation efficiency. Can display temperature, humidity, address. The product is widely used in communication rooms warehouse buildings, libraries and other places.

### Specification

General	Value
<b>1 Relative humidity</b>	
Transducer	Digital
Measurement	0%~100%
Output	Output:RS485/Modbus
Accuracy	±3%@ 20°C& 20~80%RH
<b>2 Temperature</b>	
Transducer	Digital
Output	RS485/Modbus
Accuracy	±0.3°C@20°Csee table below
Power supply	9-26VDC
Display	Optional LCD display ,with unit display
Shell Material	ABS shell
Working Environment	-20~60°C,5%-95%RH(non-condensing)
Protection Level	Ip30

# LFG101

Wall-mounted Carbon Monoxide Transmitter

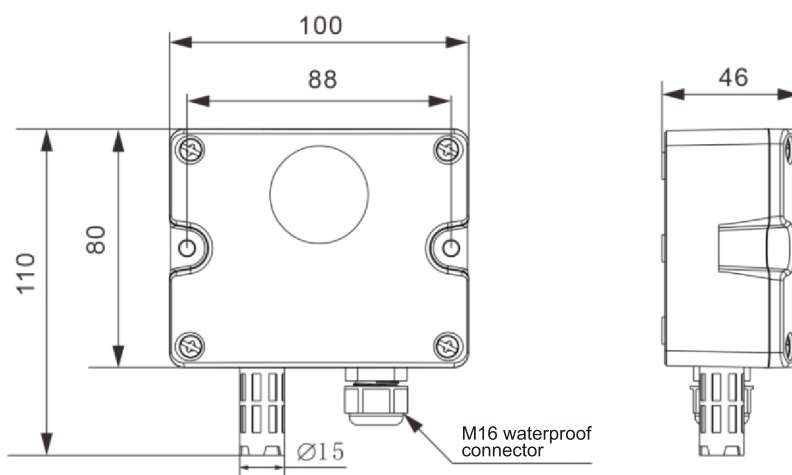

Dimension in : mm

## WIRING INSTRUCTIONS

RS485 digital output type wiring		
power supply	red	positive Power
	black	negative power
communication	green	485-A
	white	485-B

Voltage/Current Analog Output Type Wiring		
power supply	red	positive Power
	black	negative power
communication	green	Voltage/Current Output Positive
	white	Voltage/Current Output negative

LFG101 Wall-mounted Carbon Monoxide Transmitter uses electrochemical principle to detect carbon monoxide in the air, with good selectivity and stability. Three output modes of current, voltage and RS485 are optional, wide voltage power supply and power supply ant-reverse connection protection, It is suitable for carbon monoxide gas monitoring in indoor air quality detection, air conditioners, air purifiers, underground parking lots and other occasions.

## LFG101Series Order Ref NO

LFG101 - 1 A4

A B

A Range	B Output
1=500ppm	V0=0~5V
2=1000ppm	V10=0~10V
	A4=4~20mA
RS=RS485/Modbus	

## Specification

General	Value			
Output	4~20mA(3-wire)	0~5V(3-wire)	0~10V(3-wire)	RS485(4-wire)
Working Voltage	10-30Vdc	10-30Vdc	16-30Vdc	10-30Vdc
Working Temperature	-10°C~50°C			
Working Humidity	15%~90%RH			
Work pressure	1atm(Standard Atmospheric Pressure)±10%			
Measured Concentration	0-500ppm/0-1000ppm			
Accuracy	±5%F. S@25°C			
Response time(T <sub>90</sub> )	≤15s			
IP grade	Ip6x			
Service life	>5 years			

# LFG201

## Wall-mounted Carbon Dioxide Transmitter

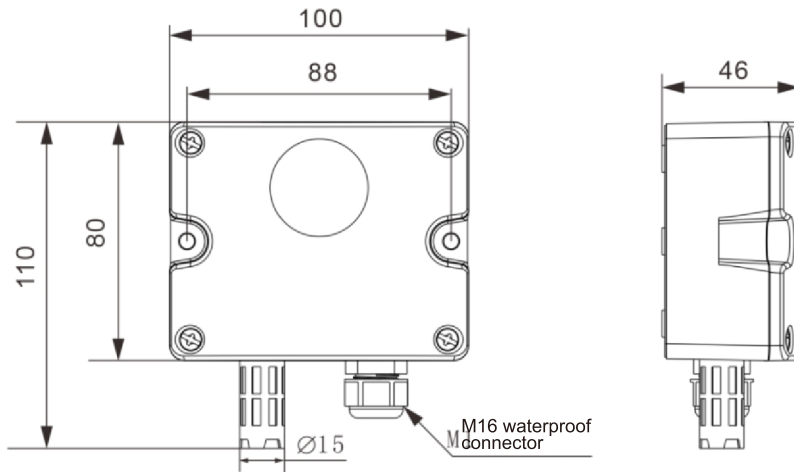

Dimension in : mm

### WIRING INSTRUCTIONS

RS485 digital output type wiring		
power supply	red	positive Power
	black	negative power
communication	green	485-A
	white	485-B

Voltage/Current Analog Output Type Wiring		
power supply	red	positive Power
	black	negative power
communication	green	Voltage/Current Output Positive
	white	Voltage/Current Output negative

LFG201 Wal-mounted Carbon Dioxide Transmitter is based on the fact that different gases have different absorption capabilities for infrared light in a specific band. It measures the concentration of the measured gas by measuring the degree of infrared light absorption. Compared with electrochemical sensors, it has the characteristics of long life and good stability, wide power supply range and power supply anti-reverse connection protection. It is suitable for indoor air quality detection, air conditioners, air purifiers, vegetable greenhouses and other occasions to measure carbon dioxide gas.

## LFG102Series Order Ref NO

LFG102 - 2 A4

A B

A Range	B Output
1=2000ppm	V0=0~5V
2=5000ppm	V10=0~10V
3=10000ppm	A4=4~20mA
RS=RS485/Modbus	

### Specification

General	Value			
Output	4~20mA(3-wire)	0~5V(3-wire)	0~10V(3-wire)	RS485(4-wire)
Working Voltage	10-30Vdc	10-30Vdc	16-30Vdc	10-30Vdc
Working Temperature	-10°C~50°C			
Working Humidity	0-80%RH(no condensation)			
Accuracy	0-2000PPM/0-5000PPM/0-10000PPM			
Measured Concentration	±(40PPm+3%Fs)@25°C			
Preheat Time	2min(available)-10min(maximum accuracy)			
Protection Level	Ip6x			
Service life	>5 years			

# LFG202

## Duct Carbon Dioxide Transmitter

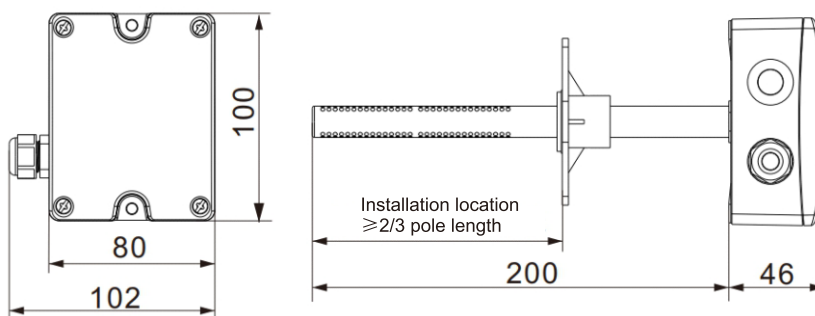

### WIRING INSTRUCTIONS

Depending on the selection, the wiring methods will be different. The following diagrams show the wiring methods of voltage output, current output, and RS485 output:

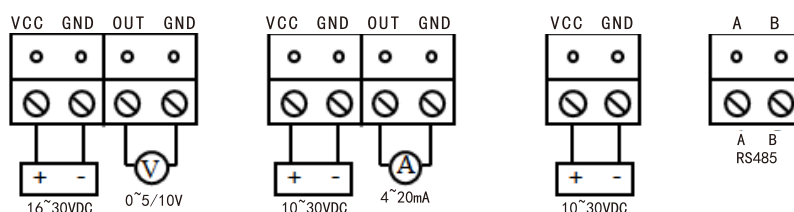

Dimension in : mm

LFG202 Duct Carbon Dioxide Transmitter is based on different gases having different absorption capabilities for infrared light in a specific band. It measures the concentration of the measured gas by measuring the degree of infrared light absorption. Compared with electrochemical sensors, it has long life and good stability. The imported high-performance NDIR sensor is used for CO<sub>2</sub> concentration measurement, with rapid response, stable performance and high accuracy; wide power supply range and high protection level of the shell, which can adapt to various harsh conditions on site. It can be widely used in the measurement of CO<sub>2</sub> concentration in ducts, offices, factory workshops, laboratories and other environments.

### LFG202Series Order Ref NO

LF202 - 1 - V10  
A B

A Range	B Output
1=2000ppm	V0=0~5V
2=5000ppm	V10=0~10V
	A4=4~20mA
	RS=RS485/Modbus

### Specification

General	Value			
Output Mode	4~20mA(3-wire)	0~5V(3-wire)	0~10V(3-wire)	RS485(4-wire)
Working Voltage	10-30Vdc	10-30Vdc	16-30Vdc	10-30Vdc
Sensor	NDIR sensor with ABC self-calibration			
Average Current	<40mA			
Working Temperature	0°C~50°C			
Working Humidity	0-85%RH(no frost)			
Measure Concentration	0-2000PPM/0-5000PPM			
Accuracy	±(40PPm+ 3%MV)ppm			
Response Time	2min			
Protection Class	shellIP65/Probe IP30			
Electromagnetic Compatibility	EN 61326-1			
Service Life	>5 years			

# LFG203

## Indoor Carbon Dioxide Transmitter

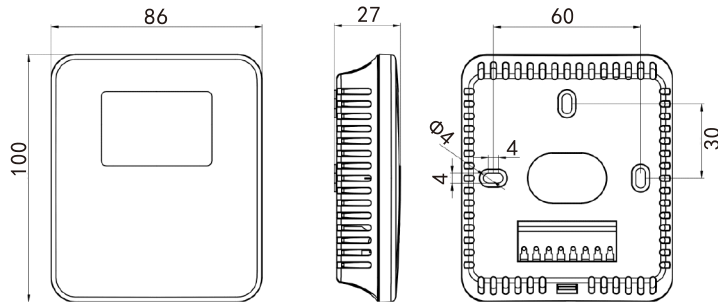

Dimension in : mm

LFG203 Indoor Carbon Dioxide Transmitter, based on principle the different gases have different absorption capabilities or infrared light in a specific band, it measures the concentration of the measured gas by measuring the degree of infrared light absorption. Compared with electrochemical sensors it has long life and stability, Imported high-performance NDIR sensor is used for CO concentration measurement, with rapid response stable performance and high accuracy wide power supply range, small size, easy installation, ideal for indoor carbon dioxide measurement. It is widely used to measure the CO<sub>2</sub> concentration in environments such as home, office, factory floors, library warehouses, etc

### LFG203Series Order Ref NO

LFG203 - 1 - V10 - D

**A** **B** **C**

A Range	B Output	C Display
1=2000ppm	V0=0~5V	D=With display
2=5000ppm	V10=0~10V	N=No display
	A4=4~20mA	
	RS=RS485/Modbus	

### Specification

General	Value			
Output Mode	4~20mA(3-wire)	0~5V(3-wire)	0~10V(3-wire)	RS485(4-wire)
Working Voltage	10-30Vdc	10-30Vdc	16-30Vdc	10-30Vdc
Sensor	NDIR sensor with ABC self-calibration			
Average Current	<45mA			
Working Temperature	0°C~50°C			
Working Humidity	0-80%RH(no condensation)			
Measure Concentration	0-2000PPM/0-5000PPM			
Accuracy	±(40PPm+ 3%MV)ppm			
Response Time	2min			
Protection Level	Ip30			
Service Life	>5 years			

# LFS10

## Wind Velocity Transmitter

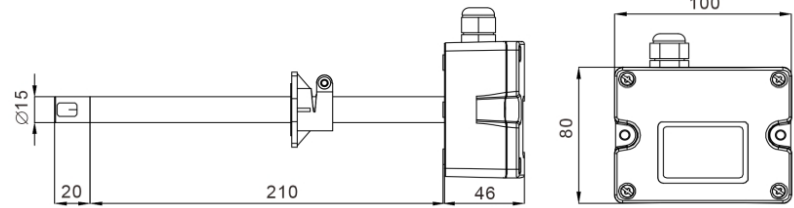

Duct Type

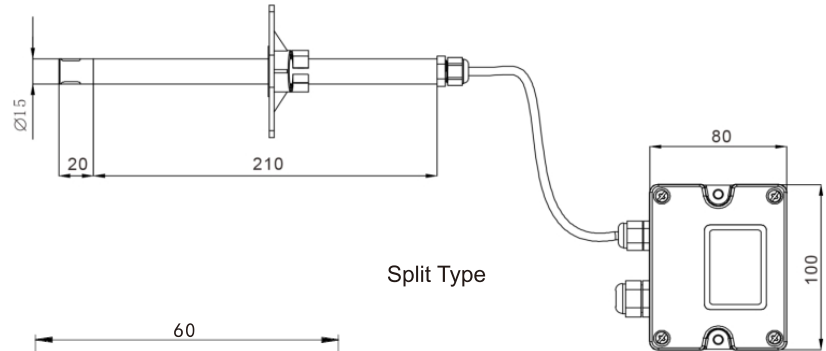

Split Type

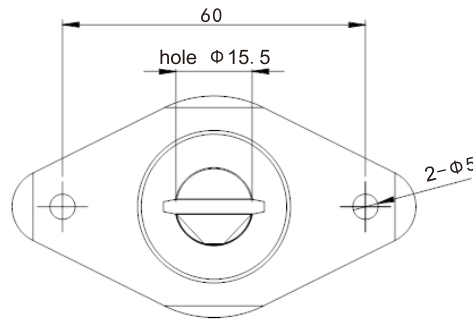

Mounting Flange

Dimension in : mm

Based on heat conduction principle, the sensor probe of Air Velocity Transmitter LFS10 is made of MEMS technology, which has the characteristics of high measurement accuracy, wide measurement range, good stability and strong environmental adaptability. It is an ideal choice for wind speed measurement in HVAC, duct air volume measurement, process and environmental control and other applications.

### LFS10 Order Ref NO

LFS101 - RS 1 D  
A B C

A Output	B Installation method	B Display
V1=0~10VDC/4~20mA	1=Duct Type Air Velocity Transmitter	D=with display
RS=RS485/Modbus	2=Split Type Air Velocity Transmitter	N=without display

### Specification

General	Value
Working Voltage	24V AC/DC±20%
Range	0~10m/s,0~15m/s,0~20m/s,0~30m/s
Accuracy	± (0.2m/s+3%of mv)(20°C,45%RH and 1013hPa)
Resolution	0.01m/s
Output Mode	RS485/Modbus,0~10VDC/4~20mA(3-wire)
Output Load	≤500Ω/(Current output),≥2KΩ(Voltage output)
Working Temperature	-10~60°C
Storage Temperature	-20~80°C
Probe Length	210mm(optional)
Display	Optional LCD display with unit display and backlight
Protection Level	Shell IP65,Probe IP20
Housing Material	Shell PC, Probe Pa6
Electromagnetic Compatibility	EN 61326-1
Certification	RoHS, EU Electrical Safety Standards CE

# SVD20 Inlet Solenoid Valve

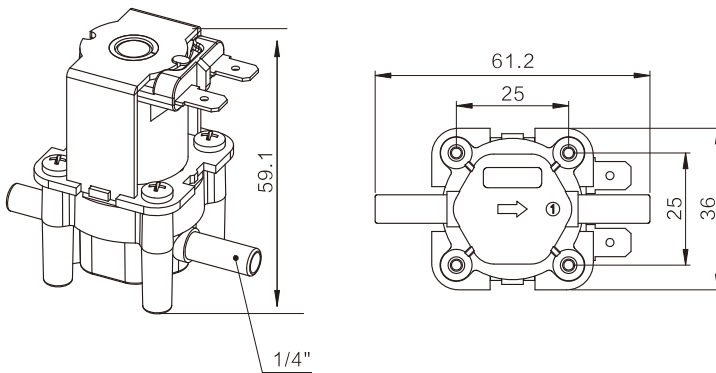
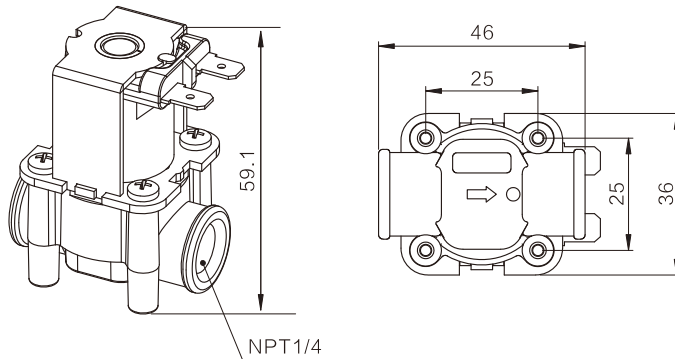
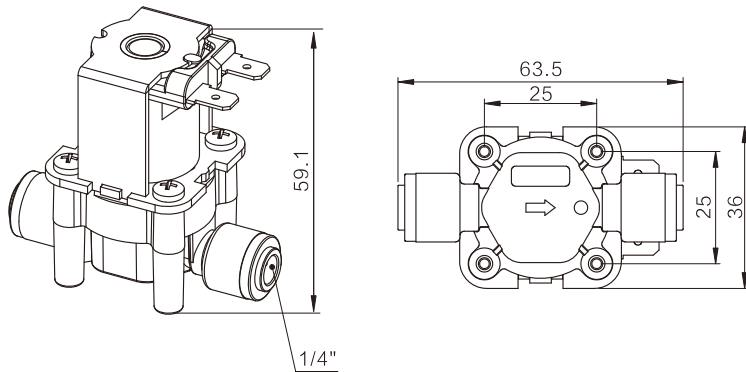

Dimensions: mm

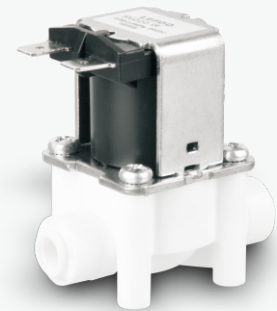

SVD20 Series of inlet and outlet solenoid valve with novel design, unique structure, also with excellent anti-blocking, anti-leakage performance, and are widely used in various types of high-grade water dispenser, RO straight drinking machine, pipeline machine, water purifying machine, coffee machine and other home appliances.

## Technical Details

Model	Value			
Rated Voltage	DC12V	DC15V	DC24V	DC36V
Working Voltage	DC12V±15%	DC15V±15%	DC24V±15%	DC36V±15%
Water Pressure Range	0.02~0.8MPa			
Medium Temperature	0~100℃			
Working Life	≥100000 times			
Water Pressure	0.3MPa			
Flow	>0.3L/min			
Spacing	Spacing: 25×25mm/42±0.2mm			
Inlet Port	Φ6.35mm、NPT1/4、1/4"			
Outlet Port	Φ6.35mm、NPT1/4、1/4"			
Options	Customer design and OEM service are provided			

# LFV18

Cold Water Inlet Solenoid Valve

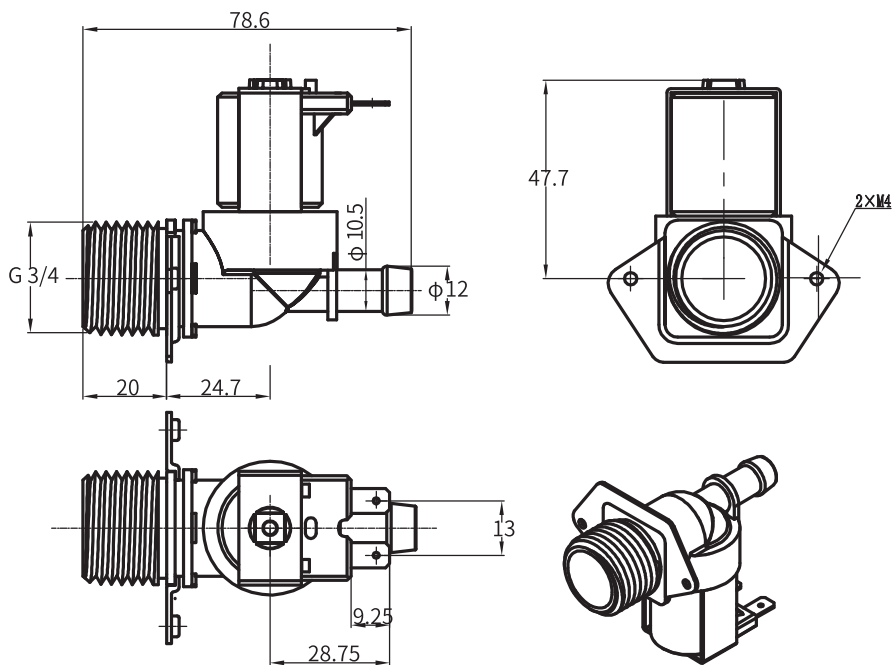
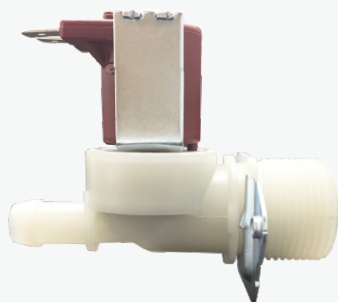

Dimension in : mm

The LFV18 series solenoid valve is mainly used in household electrical appliance, like washing machine, dish washing machine, water purifier and coffee machine. It operate using an electromagnetic solenoid coil to change the state of a valve from open to closed or vice-versa to serve the purpose of controlling liquid flow.

## Specification

General	Value			
Operating Voltage	DC12V	DC24V	AC110V	AC220V
Coil Color	Black	Yellow	Blue	Brown
Water Pressure Range	0.02MPa~1.0MPa			
Operating Temperature Range	0°C~90°C			
Insulation Class	F			
Ambient Temperature	-10°C~60°C			

## Flow Feature

Flow Rate	10L/min±15%
-----------	-------------

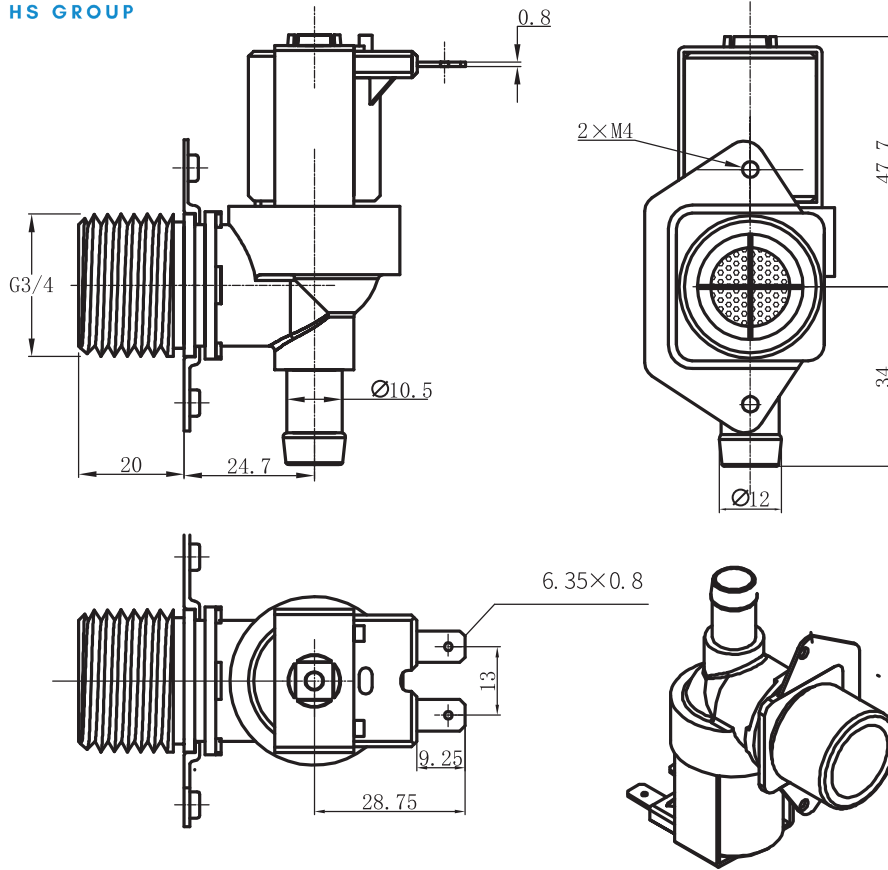

Dimension in : mm

# LFV19

Cold Water Inlet Solenoid Valve

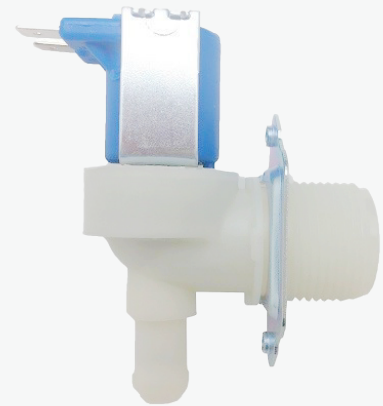

The LFV19 series solenoid valve is mainly used in household electrical appliance, like washing machine, dish washing machine, water purifier and coffee machine. It operate using an electromagnetic solenoid coil to change the state of a valve from open to closed or vice-versa to serve the purpose of controlling liquid flow.

## Specification

General	Value			
Operating Voltage	DC12V	DC24V	AC110V	AC220V
Coil Color	Black	Yellow	Blue	Brown
Water Pressure Range	0.02MPa~1.0MPa			
Operating Temperature Range	0°C~90°C			
Insulation Class	F			
Ambient Temperature	-10°C~60°C			

## Flow Feature

Flow Rate	2L/min ± 15%
-----------	--------------

# LF42

Water dispensers high and low pressure switch

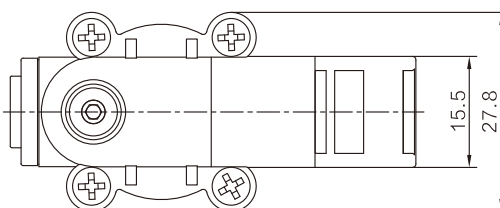
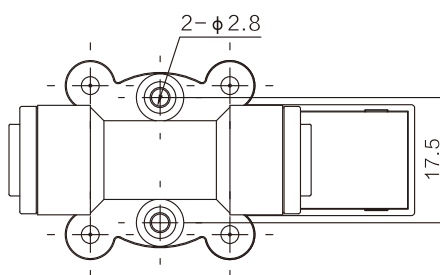
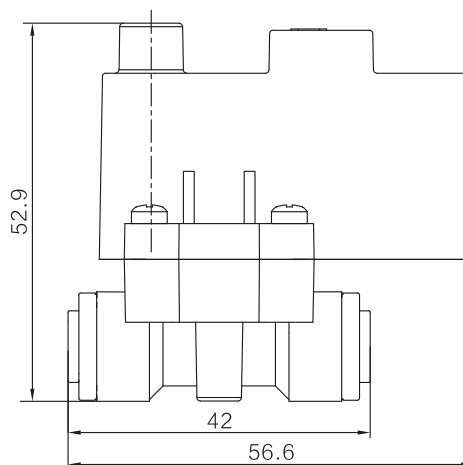

Dimension in:mm

Lf42 series pressure switch is used in water supply pressure protection of water inlet. This series include two models LF42H(high pressure protection) and LF42L(low pressure protection). LF42H is the high pressure protection switch model. If the pressure of the pressure vessel transferred reaches the setting value while the vessel is full filled with water, the switch will cut off the circuit to make the pump stop. So the pump will not be damaged. LF42L is the low pressure protection switch. If the pressure of water inlet lower than set value, RO will not work and keep dewatering, then the switch will cut off the circuit to make the pump stop. It can prevent the booster pump still working without water which may

Model	LF42H	LF42L
Media	water	water
Pressure set range	cut off pressure:2.5bar $\pm$ 0.5bar cut in pressure: 1.5bar $\pm$ 0.5bar	cut off pressure: $\leq$ 0.1 bar cut in pressure: $\geq$ 0.2 bar
Proof pressure	18bar	18bar
Durability	> 40000 times	> 40000 times
Working temperature	5~45°C	5~45°C
Switch type	Microswitch , nomal close	Microswitch , nomal open
Electrical rating	Voltage:250V AC Current:16A	Voltage:250V AC Current:16A
Terminal	4.8*0.8 blade	4.8*0.8 blade
Connector	A quarter fast interface	A quarter fast interface

Conversion:1bar=14.5psi 1MPa=10bar

# LFSV20-B

Drainage  
Solenoid Valve

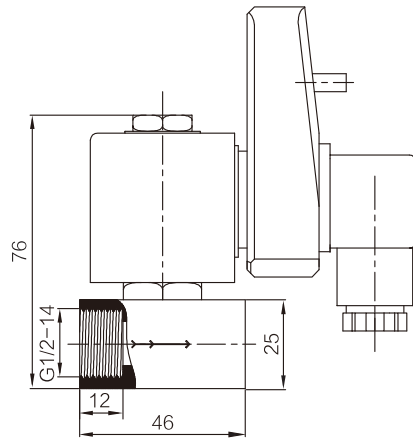
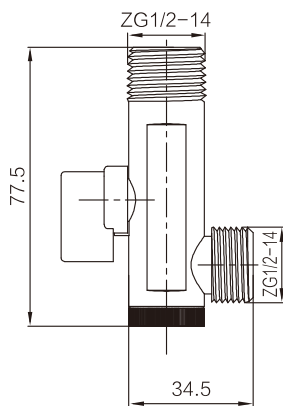
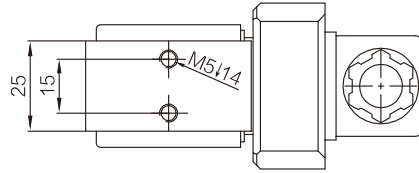
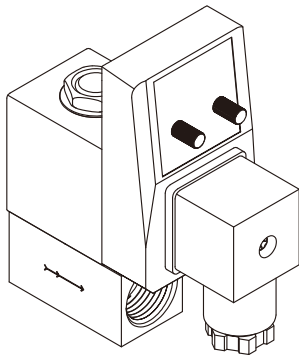

Dimension in:mm



LFSV20-B is a kind of 2/2-way solenoid valve, which is normally closed. It's used for blocking or mobilizing medium in pipe, to discharge condensate water after compress air. The main application of LFSV20-B is filter, separator, drying machine, air tank, drop foot, and other components of compressed air system. The drain time and interval time are adjustable.

## Installation and use of products

1. Before installation, make sure no impurities like dirt, copper scale and rust in the compressed air system, and the system pressure has been released for one minute.
2. Vertically installed into the pipe, the flow direction should be same as arrow in the valve shows, don't use flexible pipe without resistance to air impact in the water outlet.
3. Make sure the input power is coincident to the voltage shows in the coil. No permission to remove the coil from valve when power on, to protect coil from burning.
4. The positive pole should be connected with connection "1" when use DC voltage.

## Specification

Model	LFSV20-B
Media	Water
Media temperature	-20~80°C
Work pressure	0~16 bar
Hole diameter(mm)	φ 3.0
Interval time	0.5~45min
Drain time	0.5~10 sec
Connection type	3/8" or 1/4" is available





info@hsgrup.com.tr  
Mobile: +90 553 122 89 38  
Istanbul - Turkey

[www.hsgrup.com.tr](http://www.hsgrup.com.tr)